



SERVICE MANUAL

B SERIES TRACTORS

B-1	B-10
BIG TEN	B-12
B-110	B-112
HB-112	HB-212
B-206	B-206-E
B-207	B-207-E
B-208	B-208-S

SPECIFICATIONS	A	
ENGINE	B	
TRACTOR	C	
HYDROSTATIC DRIVE UNIT	D	
POWER TRAIN	E	
WIRING DIAGRAM	F	
B-SERIES ATTACHMENTS	G	

NOTE: When repairing any "B" Series Tractor, refer to the proper component in the Service Manual which is found in the unit being worked on. Many of the components are similar in design and care should be used in picking the proper procedure and picture.

9003453
Date



SAFETY PRECAUTIONS

**ATTENTION! BECOME ALERT!
YOUR SAFETY IS INVOLVED!**

This symbol is used to call your attention to safety precautions that should be followed by the operator to avoid accidents. When you see this symbol - **Head Its Warning.**

Many hours of lost time and much suffering is caused by the failure to practice simple safety rules.

IT IS TOO LATE TO REMEMBER WHAT SHOULD HAVE BEEN DONE AFTER THE ACCIDENT HAS HAPPENED.

OPERATION

- **KNOW THE CONTROLS** and how to stop quickly - **READ THE OPERATOR'S MANUAL.**
- **DO NOT** allow children to operate vehicle. **DO NOT** allow adults to operate it without proper instruction.
- **DO NOT** carry passengers. **KEEP CHILDREN AND PETS A SAFE DISTANCE AWAY.**
- **CLEAR** work area of objects which might be picked up and thrown.
- **TAKE ALL** possible precautions when leaving vehicle unattended: such as disengaging power take off, lowering attachments, shifting into neutral, setting parking brake, stopping engine and removing key.
- **DO NOT** stop or start suddenly when going uphill or downhill. Mow up and down the face of steep slopes; never across the face.
- **REDUCE** speed on slopes and in sharp turns to prevent tipping or loss of control. Exercise extreme caution when changing direction on slopes.
- **STAY ALERT** for holes in terrain and other hidden hazards
- **USE CARE** when pulling loads or using heavy equipment:
 - A. Use only approved drawbar hitch points.
 - B. Limit loads to those you can safely control.
 - C. Do not turn sharply. Use care when backing.
 - D. Use counterweight(s) or wheel weights when suggested in operator's manual.
- **WATCH** for traffic when crossing or near roadways.
- **KEEP** all nuts, bolts and screws tight to be sure equipment is in safe working condition.
- **DO NOT** change engine governor settings or overspeed engine.

- **DO NOT** operate equipment when barefoot or wearing open sandals. Always wear substantial footwear.
- **CAUTION:** This tractor does not have warning devices for operation on public roads or highways.
- **OPERATE TRACTOR ONLY** in daylight or good artificial light.

FUEL AND FIRE HAZARDS

- **HANDLE** gasoline with care -- it is highly flammable. Always carry and store it in an approved gasoline container
- **DO NOT** remove the fuel cap or fill fuel tanks:
 - A. When the engine is running.
 - B. When engine is hot.
 - C. While using a lantern.
 - D. While smoking.
 - E. When tractor is in a closed building.
- **DO NOT** overfill the fuel tank or spill the fuel.
- **DO NOT** run the engine in a closed area -- exhaust fumes are very dangerous.
- **NEVER** store equipment with gasoline in the tank inside a building where fumes may reach an open flame or spark.
- **ALLOW** engine to cool before storing in any enclosure.
- **TO REDUCE** fire hazard keep engine free of grass, leaves or excessive grease.

IMPLEMENTS

- **DISENGAGE** all implement clutches and shift into neutral before attempting to start engine.
- **DISENGAGE** power to implements and stop engine before leaving operator position.
- **DISENGAGE** power to implement(s), stop engine and remove ignition key before making any inspections, adjustments or repairs to tractor or implements.
- **DISENGAGE** power to implements when transporting or not in use.
- When using any implements **NEVER** direct discharge of material toward bystanders or allow anyone near vehicle while in operation

- **KEEP** vehicle and implements in good operating condition and keep safety devices in place. Use guards as instructed in operator's manual. Replace lost or damaged safety decals immediately.
- **VEHICLE** and implements should be stopped and inspected for damage after striking a foreign object and the damage should be repaired before restarting and operating the equipment.
- **REMEMBER** that safe operation is no accident.
- When using vehicle with **MOWER**:
 - A. Check blade mounting bolts for proper tightness at frequent intervals.
 - B. Never operate mower unless deflector assembly or vacuum collector adapter assembly is firmly attached to the mower discharge.
 - C. When cleaning material out of the hoses or blower of the vacuum collector be sure to stop both tractor and blower engines and wait until all moving parts have stopped before removing hoses. **ALSO, ALWAYS REMOVE SPARK PLUG WIRE ON BLOWER** engine and fasten it so that it cannot touch spark plug before placing hands inside blower housing. Moving the fan blades could possibly start engine and blower running if plug wire is not removed.

- D. When using the roving vacuum nozzle **ALWAYS** stop tractor engine and engage parking brakes before leaving tractor seat. **ALSO NEVER** remove hose from blower entrance or discharge openings unless blower engine is stopped and all moving parts have come to a stop.

SAFETY DECALS

The safety warning signs reproduced on this page are placed at strategic locations on the top of the mower housing and tractor frame (as shown in Figure 10 in Tractor Section and 15 in Mower Section) as a constant reminder to the operator of the most important safety precautions in the operation of the mower.

If any of these signs are lost or damaged replace them at once for the operators safety. They can be purchased from your Aulis-Chalmers Lawn and Garden Equipment Dealer.

AVOID ACCIDENTS

BUILT IN SAFETY FEATURES CAN BE EFFECTIVE ONLY IF PROPERLY MAINTAINED AND UTILIZED.

SAFETY AND OPERATIONAL DECALS

WARNING
DO NOT OPERATE MOWER
WITHOUT DEFLECTOR OR
VACUUM COLLECTOR IN PLACE.

DANGER
STAND CLEAR OF
DISCHARGE OPENING

CAUTION
KEEP HANDS & FEET
FROM UNDER MOWER



ALLIS-CHALMERS
Lawn and Garden Equipment
P.O. Box 997
Port Washington, WI 53074

Part No. 9003453
February, 1976
Printed in U.S.A.

INDEX

SPECIFICATIONS

B-1 A-1
B-10 S N 15001-31227 A-2
Big TEN A-3
B-10 S N 50001 and Up A-4
B-12 A-5
B-110 A-6
B-112 A-7
HB-112 A-8
B-206 and B-206-F A-9
B-207 and B-207-E A-10
B-208 and B-208-S A-11
B-210, B-212, and HB 212 A-12

A 

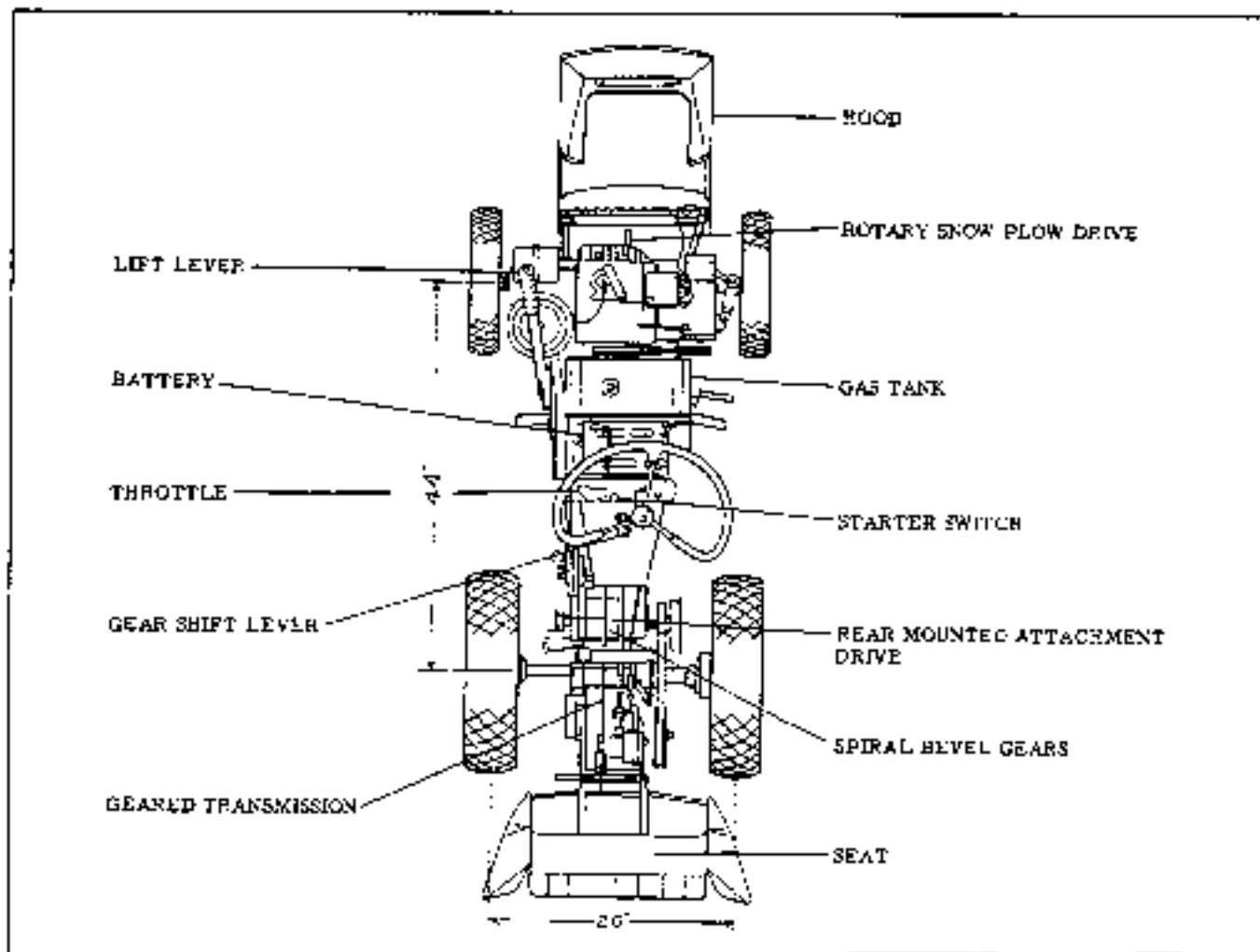

**SPECIFICATIONS
MODEL B-1 TRACTOR**

ENGINE

Make	Briggs & Stratton
Type	4 cycle - air cooled
Horse Power	7-1/4
Bore and Stroke	3" x 2-5/8"
Displacement	18.55 cu. in.
R. P. M.	3000 max. full load
Air Cleaner	Oil bath
Starter	Electric & manual
Governor	Mechanical (flyweight)
Electrical System	12 volt - combination starter-generator
Ignition System	Magneto

TRANSMISSION

Sliding spur gear and spiral bevel gear.
Three speeds forward and one reverse.

DIFFERENTIAL

Engine, Trans. Drive Spur gear with
controlled traction direct shaft with flexible
couplings.

The Allis-Chalmers Manufacturing Company reserves the right to make changes in the above specifications or to add improvements at any time without notice or obligation.

CAPACITY

Engine Case	5 pts.
Fuel Tank	6 qts.
Transmission	1-1/2 qts.

SPEEDS

First	2 MPH
Second	3-3/4 MPH
Third	6 MPH

DIMENSIONS

Height (at steering wheel)	37-1/4"
Height (at hood line)	35-3/8"
Width	34-1/4"
Length	68"
Wheel Tread	26"
Wheel Base	64"
Clearance (front axle)	9"
Clearance (differential)	6"
Clearance (drawbar)	7"
Clearance (center housing)	15-1/4"

SHIPPING WEIGHT - Approx. 600 lbs.

SPECIFICATIONS
 Model B-10 Wheel Tractor
 Ser. No. 150D.-51227

ENGINE

Make	Briggs & Stratton
Type	4 cycle - air cooled
Horse Power	9
Bore and Stroke	3" x 3-1/4"
Displacement	22.97 cu. in.
R. P. M.	3600 max. full load
Air Cleaner	Oil foam
Starter	Electric & manual
Governor	Mechanical (flyweight)
Electrical System	12 volt - combination starter-generator
Ignition System	Magneto

TRANSMISSION

Sliding spur gear and spiral bevel gear,
 Three speeds forward and one reverse.

DIFFERENTIAL

Planetary gear with controlled traction.

CAPACITY

Engine Case	4 pps.
Fuel Tank	6 qts.
Transmission	1-1/2 qts.

SPEEDS

First	2 MPH
Second	3-3/4 MPH
Third	6 MPH

DIMENSIONS

Height (at steering wheel)	37-1/4"
Height (at hood line)	33-3/8"
Width	34-1/4"
Length	68"
Wheel Tread	36"
Wheel Base	44"
Clearance (front axle)	9"
Clearance (differential)	6"
Clearance (drawbar)	7"
Clearance (center housing)	15-1/4"

SHIPPING WEIGHT - Approx. 685 lbs.

TIRE PRESSURES

Rear	8 PSI.
Front	12 PSI.

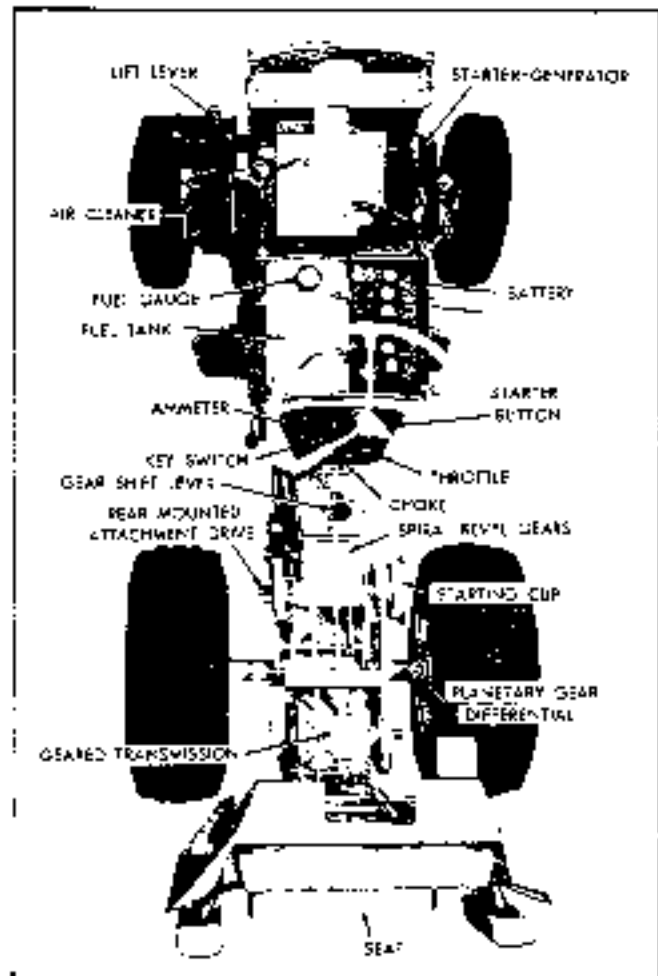

The Allis-Chalmers Manufacturing Company reserves the right to make changes in the above specifications or to add improvements at any time without notice or obligation.

SPECIFICATIONS
Model Big Ten Wheel Tractor

ENGINE

Make Briggs & Stratton
 Type 4 cycle - air cooled
 Horse Power 10
 Bore and Stroke 3-1/16" x 3-1/4"
 Displacement 25.94 cu. in.
 R. P. M. 3600 RPM full throttle full load
 Air Cleaner Oil foam
 Starter Electric & manual
 Governor Mechanical (flyweight)
 Electrical System 12 volt-combination starter-generator
 Ignition System Magneto

BATTERY

Make Allis-Chalmers-40 ampere hour-12 volt

TRANSMISSION

Sliding spur gear and spiral bevel gear. Three speeds forward and one reverse, with standard drive, six speeds forward and two reverse with optional Hi-Lo range policy.

DIFFERENTIAL

Planetary gear with controlled traction.

SPEEDS - Standard Drive

First 2 MPH
 Second 3-3/4 MPH
 Third 6 MPH

SPEEDS - Hi-Lo Drive (Optional)

First Hi 1.5 MPH - Lo .8
 Second Hi 3.5 - Lo 1.3
 Third Hi 6.0 - Lo 2.2
 Reverse Hi 3.0 - Lo 1.1

DIMENSIONS

Height (at steering wheel) 37-1/4"
 Height (at hood line) 33-3/8"
 Width 34-1/4"
 Length 68"
 Wheel Tread 26"
 Wheel Base 44"
 Clearance (Front Axle) 9"
 Clearance (Differential) 5"
 Clearance (Drawbar) 9"
 Clearance (Center housing) 15-1/4"

SHIPPING WEIGHT - Approx. 620 lbs.

TIRE PRESSURE

	Standard Tractor	With Loader	With Fork Lift
Rear	6 PSI	20 PSI	20 PSI
Front	12 PSI	14 PSI	20 PSI

CAPACITY

Engine Crankcase 4 pts.
 Fuel Tank 6 qts. "regular" gas
 Transmission 1-1/2 qts. SAE 90 oil
 Bevel gear housing 1 pt. SAE 90 oil

The Allis-Chalmers Manufacturing Company reserves the right to make changes in the above specifications or to add improvements at any time without notice or obligation.

SPECIFICATIONS
 Model E-10 Wheel Tractor
 S/N 50001 and up

ENGINE

Make Briggs & Stratton
 Type 4 cycle - air cooled
 Horse Power 10
 Bore and Stroke 3-1/16" x 3-1/4"
 Displacement 23.94 cu. in.
 R. P. M. 3600 RPM full throttle full load
 Air Cleaner Oil foam
 Starter Electric & manual
 Governor Mechanical (flyweight)
 Electrical System 12 volt-combination starter-generator
 Ignition System Magneto

BATTERY

Make Allis-Chalmers-40 ampere hour-12 volt

TRANSMISSION

Sliding spur gear and spiral bevel gear. Three speeds forward and one reverse, with standard drive, six speeds forward and two reverse with optional Hi-Lo range pulley.

DIFFERENTIAL

Planetary gear with controlled traction.

SPEEDS - Standard Drive

First 3 MPH
 Second 3-3/4 MPH
 Third 5 MPH

SPEEDS - Hi-Lo Drive (Optional)

First Hi 1.5 MPH - Lo .5
 Second Hi 3.5 Lo 1.3
 Third Hi 6.0 Lo 3.3
 Reverse Hi 3.0 Lo 1.1

DIMENSIONS

Height (at steering wheel) 37-1/4"
 Height (at hood line) 35-3/8"
 Width 36-1/4"
 Length 63"
 Wheel Tread 25"
 Wheel Base 44"
 Clearance (Front Axle) ?"
 Clearance (Differential) 6"
 Clearance (Drawbar) 7"
 Clearance (Center housing) 15-1/4"

SHIPPING WEIGHT - Approx. 680 lbs.

TIRE PRESSURE

	Standard Tractor	With Loader	With Fork Lift
Rear	5 PSI	20 PSI	20 PSI
Front	12 PSI	14 PSI	20 PSI

CAPACITY

Engine Crankcase 4 pts.
 Fuel Tank 6 qts. "regular" gas
 Transmission 1-1/2 qts. SAE 90 oil
 Bevel gear housing 1 pt. SAE 90 oil

The Allis-Chalmers Manufacturing Company reserves the right to make changes in the above specifications or to add improvements at any time without notice or obligation.

SPECIFICATIONS
Model B-12 Wheel Tractor

ENGINE

Make Briggs & Stratton
 Type 4 cycle - air cooled
 Horse Power 12
 Bore and Stroke 3-1/4" x 3-7/16"
 Displacement 30.18 cu. in.
 R. P. M. 3600 RPM full throttle full load
 Air Cleaner Oil Inert
 Starter Electric & manual
 Governor Mechanical (flyweight)
 Electrical System 12 volt-combination starter-generator
 Ignition System Magneto

BATTERY

Make Allis-Chalmers-40 ampere hour-12 volt

TRANSMISSION

Sliding spur gear and spiral bevel gear. Three speeds forward and one reverse, with standard drive, six speeds forward and two reverse with optional Hi-Lo range pulley.

DIFFERENTIAL

Planetary gear with controlled traction.

SPEEDS - Standard Drive

First 2 MPH
 Second 3-3/4 MPH
 Third 6 MPH

SPEEDS - Hi-Lo Drive (Optional)

First	Hi 1.5 MPH	Lo 1.8
Second	Hi 3.5	Lo 1.3
Third	Hi 6.0	Lo 2.2
Reverse	Hi 3.0	Lo 1.1

DIMENSIONS

Height (at steering wheel) 37-1/4"
 Height (at hood line) 33-3/8"
 Width 34-1/4"
 Length 66"
 Wheel Tread 26"
 Wheel Base 64"
 Clearance (front axle) 9"
 Clearance (differential) 6"
 Clearance (drawbar) 7"
 Clearance (center housing) 15-1/4"

SHIPPING WEIGHT - Approx. 680 lbs.

TIRE PRESSURE

	Standard Tractor	With Loader	With Fork Lift
Rear	8 PSI	20 PSI	20 PSI
Front	10 PSI	14 PSI	20 PSI

CAPACITY

Engine Crankcase 4 pts.
 Fuel Tank 9 qts. "regular" gas
 Transmission 1-1/2 qts. SAE 90 oil
 Bevel gear housing 1 qt. SAE 90 oil

The Allis-Chalmers Manufacturing Company reserves the right to make changes in the above specifications or to add improvements at any time without notice or obligation.

SPECIFICATIONS
Model B-112 Wheel Tractor

ENGINE

Make Briggs & Stratton
 Type 4 cycle - air cooled
 Horse Power 12
 Bore and Stroke 3-1/4 x 3-7/16
 Displacement 32.16
 R.P.M. 3600 RPM full throttle full load
 Air Cleaner Oil Foam
 Starter Electric
 Governor Mechanical (Byweight)
 Electrical System 12 volt-combination starter-generator
 Ignition System Magneto

BATTERY

Make Alais-Chalmers-40 ampere hour-12 volt

TRANSMISSION

Sliding spur gear and spiral bevel gear. 21 speeds forward and 7 reverse with standard variable pitch sleeve system.

DIFFERENTIAL

Planetary gear with controlled traction.

SPEEDS - Standard Drive

First	7 Speed Ranges	Min. 0.8 MPH	Max. 1.7 MPH
Second	7 Speed Ranges	2.0 MPH	4.0 MPH
Third	7 Speed Ranges	3.3 MPH	6.5 MPH
Reverse	7 Speed Ranges	3.7 MPH	3.8 MPH

DIMENSIONS

Height (At Steering Wheel) 37-3/4"
 Height (At Hood Line) 33-1/4"
 Width 36"
 Length 72"
 Wheel Tread 17-1/2" rear, 30-1/4" front
 Wheel Base 48"
 Clearance (Front Axle) 0"
 Clearance (Differential) 6"
 Clearance (Drawbar) 7"
 Clearance (Center Housing) 15-1/4"

SHIPPING WEIGHT - Approx. 745 lbs.

TIRE PRESSURE

	Standard Tractor	With Loader
Rear	8 PSI	12 PSI
Front	10 PSI	25 PSI

CAPACITY

Engine Crankcase 4 pts.
 Fuel Tank 6 qts. "regular" gas
 Transmission 1-1/2 qts. 50EP Oil
 Bevel Gear Housing 1 pt. 50EP Oil

Alais-Chalmers Manufacturing Company reserves the right to add to or change these specifications at any time without notice.

SPECIFICATIONS
Model HB - (12 Wheel) Tractor

ENGINE

Make Briggs & Stratton
 Type 4 cycle - air cooled
 Horse Power 12
 Bore and Stroke 3-1/4 x 3-7/16
 Displacement 50.16
 R.P.M. 3600 RPM (all throttle full load)
 Air Cleaner Oil Foam
 Starter Electric
 Governor Mechanical (flyweight)
 Electrical System 12 volt-combination starter-generator
 Ignition System Magneto

BATTERY

Make Allis-Chalmers-40 ampere hour-12 volt

TRANSMISSION

Hydrostatic drive with piston pump and piston motor.

DIFFERENTIAL

Planetary gear with controlled traction.

SPEEDS - Variable

Forward 0-7.2 MPH
 Reverse 0-4.4 MPH

DIMENSIONS

Height (At Steering Wheel) 37-5/4"
 Height (At Hood Line) 33-1/4"
 Width 40"
 Length 72"
 Wheel Tread 29-1/2" rear, 30-1/4" front
 Wheel Base 48"
 Clearance (Front Axle) 9"
 Clearance (Differential) 6"
 Clearance (Drawbar) 7"
 Clearance (Center Housing) 15-1/4"

SHIPPING WEIGHT - Approx. 745 lbs.

TIRE PRESSURE

	Standard Tractor	With Loader
Rear	8 PSI	12 PSI
Front	10 PSI	25 PSI

CAPACITY

Engine Crankcase 4 pts.
 Hydrostatic Transmission 1 3/4 QTS. Dexron ATF
 Transmission 1-1/2 qts. 80EP Oil
 Final Drive Gearcase 1 1/2 QTS. 80 EP Oil

Allis-Chalmers Manufacturing Company reserves the right to add to or change these specifications at any time without notice.

SPECIFICATIONS

Model B-206 and B-206-E Wheel Tractor

ENGINE

Make Briggs & Stratton
Type 4 cycle - air cooled
Horse Power 6
Bore and Stroke 2 3/4 x 2 3/8
Displacement 14.1
R.P.M. 3600 RPM full throttle full load
Air Cleaner Oil Foam
Starter Recoil (12 volt elec. w/4 amp. alternator opt.)
Governor Mechanical (flyweight)
Electrical System(B-206-E) 12 volt-combination starter-generator
Ignition System Magneto

BATTERY

Make Allis-Chalmers-25 amp. Hour-12 volt
(Optional w/elec. start)

TRANSMISSION

Transaxle - 3 speeds Forward - 1 Reverse

DIFFERENTIAL

Bevel Gear, Internal to Transaxle

SPEEDS - Standard Drive

First 1.27 MPH
Second 2.48 MPH
Third 3.70 MPH
Reverse 1.72 MPH

DIMENSIONS

Height (At Steering Wheel) 34"
Height (At Hood Line) 28.75"
Width 25.5"
Length 53.25"
Wheel Tread 20.5"
Wheel Base 30.75"
Clearance (Front Axle) 3"
Clearance (Differential) 4.5"
Clearance (Drawbar) 8.5"
Clearance (Center Hoisting)

SHIPPING WEIGHT - B-206 335 lbs
 B-206-E 350 lbs

TIRE PRESSURE

Standard Tractor

Rear 12 PSI
Front Semi-pneumatic/No pressure

CAPACITY

Engine Crankcase 2 1/4 pts.
Fuel Tank 2 qts.
Transmission 1 1/2 pts. SAE 90

Allis-Chalmers Manufacturing Company reserves the right to add to or change these specifications at any time without notice.

SPECIFICATIONS

Model B-207 and B-207-E Wheel Tractor

ENGINE

Make Briggs & Stratton
Type 4 cycle - air cooled
Horse Power 7
Bore and Stroke 3" x 2 3/8
Displacement 16.79
R.P.M. 3600 RPM (full throttle full load)
Air Cleaner Oil Foam
Starter B-207 (Recoil) B-207-E (Electric)
Governor Mechanical (flyweight)
Electrical System (B-207-E) 12 volt-combination starter-generator
Ignition System Magneto

BATTERY

Make (B-207-E) Allis-Chalmers-40 ampere hour-12 volt

TRANSMISSION

Transaxle with 3 Speeds Forward and 1 Reverse

DIFFERENTIAL

Bevel Gear Internal to Transaxle

SPEEDS - Standard Drive

First 2.1 MPH
Second 3.8 MPH
Third 5.5 MPH
Reverse 3.9 MPH

DIMENSIONS

Height (At Steering Wheel) 35"
Height (At Hood Line) 29 1/2"
Width 31 1/2"
Length 58"
Wheel Tread 23 1/4"
Wheel Base 41"
Clearance (Front Axle) 8 5/8"
Clearance (Differential) 5"
Clearance (Drawbar) 6 3/4"

SHIPPING WEIGHT - B-207 w/mower 515 lbs
B-207-E w/mower 530 lbs

TIRE PRESSURE

Standard Tractor

Rear 7 to 9 PSI
Front 9 PSI

CAPACITY

Engine Crankcase 2 1/4 pts.
Fuel Tank 7/8 gallon
Transmission 90 SAE (Fill to Oil Level; Check Plug)

Allis-Chalmers Manufacturing Company reserves the right to add to or change these specifications at any time without notice.

SPECIFICATIONS

Model B-208 and B-208-S Wheel Tractor

ENGINE

Make Briggs & Stratton
 Type 4 cycle • air cooled
 Horse Power 8
 Bore and Stroke 2" x 2 3/4"
 Displacement 19.4
 R.P.M. 3600 RPM full throttle full load
 Air Cleaner Oil Foam
 Starter Electric
 Governor Mechanical (flyweight)
 Electrical System 12 volt • combination starter • generator
 Ignition System Magneto

BATTERY

Make Allis-Chalmers-40 ampere hour-12 volt

TRANSMISSION

Transaxle with 3 Speeds Forward and 1 Reverse

DIFFERENTIAL

Bevel Gear Internal to Transaxle

SPEEDS - Standard Drive

First 2.1 MPH
 Second 3.6 MPH
 Third 5.6 MPH
 Reverse 2.9 MPH

DIMENSIONS

	B-208	B-208-S
Height (At Steering Wheel)	35"	35 1/2"
Height (At Hood Line)	29 1/2"	30"
Width	31 1/2"	32 1/2"
Length	58"	58"
Wheel Tread	23 1/4"	23 1/4"
Wheel Base	41"	41"
Clearance (Front Axle)	6 5/8"	6 1/2"
Clearance (Differential)	5"	5 1/2"
Clearance (Drawbar)	6 3/4"	7 1/4"

SHIPPING WEIGHT - Approx. 550 lbs 640 lbs

TIRE PRESSURE

	Standard Tractor	With Loader
Rear	7 to 9 PSI	12 PSI
Front	9 PSI	25 PSI

CAPACITY

Engine Crankcase 2 1/4 pts.
 Fuel Tank 7 7/8 gallon
 Transmission 90 SAE (Fill to Oil Level Check Plug)

Allis-Chalmers Manufacturing Company reserves the right to add to or change these specifications at any time without notice.

SPECIFICATIONS

Model B-210, B-212, and HB-212 Wheel Tractor

ENGINE

Make Briggs & Stratton
Type 4 cycle - air cooled
Horse Power B-210 (10 HP) B-212 and HB-212 (12HP)
Bore and Stroke . . . B-210 (3 1/16" x 3 1/4") B-212 and HB-212
(3 1/4" x 3 7/16")
Displacement B-210 (23.94) B-212 and HB-212 (30.16)
R.P.M. 3600 RPM full throttle full load
Air Cleaner Oil Foam
Starter . . . B-210 (Electric and Manual) B-212 and HB-212 Electric
Governor Mechanical (flyweight)
Electrical System 12 volt-combination starter-generator
Ignition System Magneto

BATTERY

Make Allis-Chalmers-40 ampere hour-12 volt

TRANSMISSION B-210 and B-212

Sliding spur gear and spiral bevel gear, 21 speeds forward and 7 reverse with standard variable pitch sheave system.

TRANSMISSION HB-212

Hydrostatic drive with piston pump and piston motor.

DIFFERENTIAL

Planetary gear with controlled traction.

SPEEDS - Standard Drive B-210 and B-212

First	7 Speed Ranges	Min. 0.5 MPH	Max. 1.7 MPH
Second	7 Speed Ranges	2.0 MPH	4.0 MPH
Third	7 Speed Ranges	3.3 MPH	6.6 MPH
Reverse	7 Speed Ranges	1.7 MPH	3.4 MPH

SPEEDS - Variable HB-212

Forward 0-7.2 MPH
Reverse 0-4.4 MPH

DIMENSIONS

Height (At Steering Wheel) 37-3/4"
Height (At Hood Line) 33-1/4"
Width 54"
Length 72"
Wheel Tread 25 1/2" rear, 30-1/4" front
Wheel Base 43"
Clearance (Front Axle) 9"
Clearance (Differential) 5 1/2"
Clearance (Drawbar) 7 1/4"

SHIPPING WEIGHT - Approx. 745 lbs.

TIRE PRESSURE

	Standard Tractor	With Loader
Rear	8 PSI	12 PSI
Front	10 PSI	25 PSI

CAPACITY

Engine Crankcase 4 pts.
Fuel Tank 6 qts. "regular" gas
Transmission 1-1/2 qts. 80EP Oil
Bevel Gear Housing 1 pt. 80EP Oil

Allis-Chalmers Manufacturing Company reserves the right to add to or change these specifications at any time without notice.

INDEX

ENGINE

ENGINE, OPERATING AND
MAINTENANCE INSTRUCTIONS B-1

ENGINE, DRIVE SHAFT AND COUPLING REMOVAL

B-1 B-21

B-10 PRIOR TO S/N 50001 B-22

B-10 Eff. W/S, N 50001 and Up B-23

Big TEN, B-12, B-110, B-212, HB-112 B-23

B-210, B-213, HB-212 B-23

STORING YOUR TRACTOR B-24

DIAGNOSING ENGINE DIFFICULTY B-25

B



THIS PAGE INTENTIONALLY BLANK

ENGINE OPERATING AND MAINTENANCE INSTRUCTIONS

TRACTOR MODEL	ENGINE MODEL	ENGINE H.P.	PAGE
B-1	190	7-1/4	B-6
B-10	243431	10	B-11
Big Ten	242431	10	B-11
B-12	300401	12	B-16
B-110	243431	10	B-11
B-112	300401	12	B-16
HB-112	300401	12	B-16
B-206	146700	6	B-1
B-207	170700	7	B-1
B-210	243431	10	B-11
B-212	300401	12	B-16
HB-212	300401	12	B-16

NOTE: This chart is a listing of Tractors and Engines by model number. Refer to page number in right column for instructions.

MODELS 146700 and 170700

Section 1 BEFORE STARTING

- 1 **FILL SUMP WITH OIL** - Use a high quality detergent oil classified "For Service SC or SD or MS". Nothing should be added to the recommended oil.

Summer - (Over 40° F) Use SAE 30 Oil

Winter - (Under 40° F) Use SAE 5W-20
If not available use SAE 10W
(Below 0° F) Use SAE 10W
diluted with 10% kerosene

DIRECTIONS: Place the engine level. **FILL THE OIL SUMP TO OVERFLOWING**. Pour slowly. Capacity 2 3/4 pints

- 2 **FILL FUEL TANK** - Use clean, fresh, leaded or non-leaded "REGULAR" grade automotive gasoline. Fill tank completely!

DO NOT MIX OIL WITH GASOLINE.

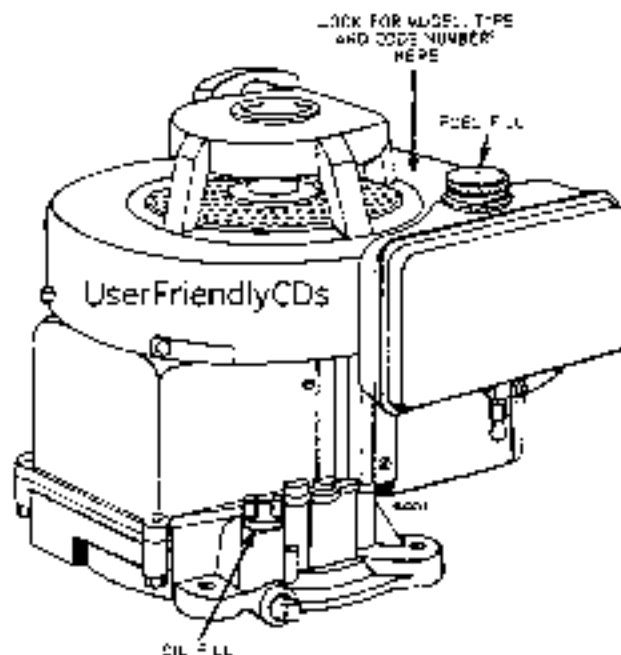

1 BE SURE THE STOP SWITCH IS AWAY FROM SPARK PLUG

CAUTION: ALWAYS KEEP HANDS AND FEET CLEAR OF MOWER BLADE OR OTHER ROTATING MACHINERY.



Move Stop Switch away from Spark Plug

2 OPEN FUEL VALVE

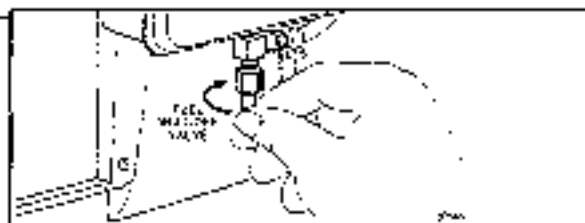

Opening Fuel Valve

3 CHOKE THE CARBURETOR

a. Manual Type

Move lever in direction of arrow so fully closed choke position. Set governor control in normal operating position.

b. Choke-A-Matic

Move lever to "Full Choke" or "Start" position.

Note: This should fully close choke on carburetor. If it does not, remote control must be re-adjusted. See "Choke-A-Matic Carburetor" Adjustments, Section 4.

Note: A warm engine requires less choking than a cold engine.



a. Manual Type

b. Choke-A-Matic

4 START ENGINE

a. Rewind Starter Grasp starter grip as illustrated and pull out cord rapidly. Repeat if necessary with choke opened slightly. When engine starts open choke gradually.

b. Rope Starter Wind the starter rope around the pulley in direction shown by arrow. Pull the rope with a quick full arm stroke. Repeat if necessary with choke opened slightly. When engine starts open choke gradually.

c. Electric Starter Press starter button on powered equipment. When engine starts open choke gradually.

CAUTION: The 110 volt electric starter is equipped with a three-prong plug for your safety. If a longer cord is used it should also have three-prong and three-hole plugs. If the outlet or receptacle is the two-hole type, an adapter must be used. To get proper grounding, fasten the ground lead on the adapter to something electrically grounded, such as the metal box on the end of a grounded metal conduit.



a. Rewind Starter

b. Rope Starter

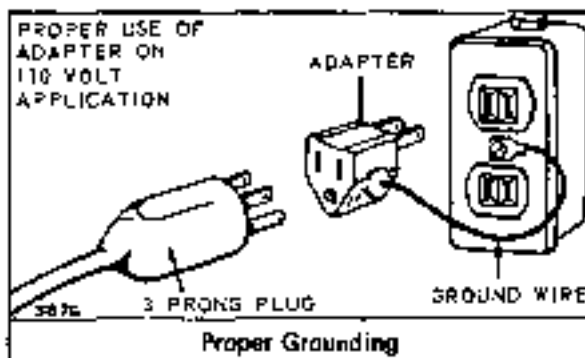

Proper Grounding

Section
2

STARTING (cont'd)

SPECIAL LOW TEMPERATURE STARTING PROCEDURE 1. Turn needle valve on carburetor, 1/8 turn counterclockwise from normal summer adjustment. **Note:** If fuel drips out of carburetor while trying to start engine, the engine is over chocked. Pull starter several times or push starter button with choke open. 2. Be sure to use the proper weight of oil for the air temperature expected. 3. Disconnect all external loads. Any V-belt drives must be removed or loosened so that the belts are standing still for satisfactory operation below freezing. Starter, motor and battery are designed to start the engine only. 4. Keep battery and engine warm if possible. If it is not possible to keep the entire unit warm, there is a big advantage in keeping the battery warm until it is required for starting. A warm battery has much more starting capacity than a cold battery.

5 STOP ENGINE

- Manual Choke** Push the stop switch against end of spark plug.
- Choke-A-Matic** Move control lever to "stop" position.

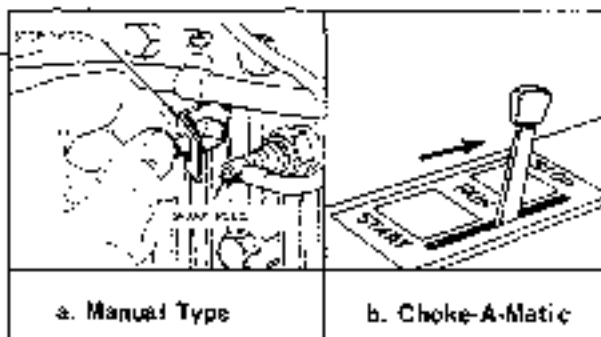

Section
3

MAINTENANCE

- CHECK OIL LEVEL** before starting engine and after every 5 hours of operation. (Take care to remove dirt around filler plug.) Be sure oil level is maintained FULL TO POINT OF OVERFLOWING.
- CHANGE OIL** after first 5 hours of operation. Thereafter change oil every 25 hours of operation. Remove oil drain plug and drain oil while engine is warm. Replace oil drain plug. Remove oil minder or oil filler plug and refill with new oil of proper grade. Replace oil filler plug.
- CLEAN AIR CLEANER** and re-oil element every 25 hours under normal conditions.

- Remove two screws and lift off complete air cleaner assembly.
- Remove screen and spacers from foam element.
- Remove foam element from air cleaner body.
- A - Wash foam element in kerosene or liquid detergent and water to remove dirt.
B - Wrap foam in cloth and squeeze dry.
C - Saturate foam in engine oil. Squeeze to remove.
D - Assemble parts - fasten to carburetor with screw.

When assembling make certain the lip of the foam element extends over edge of the air cleaner body. The foam element lip will form a protective seal.

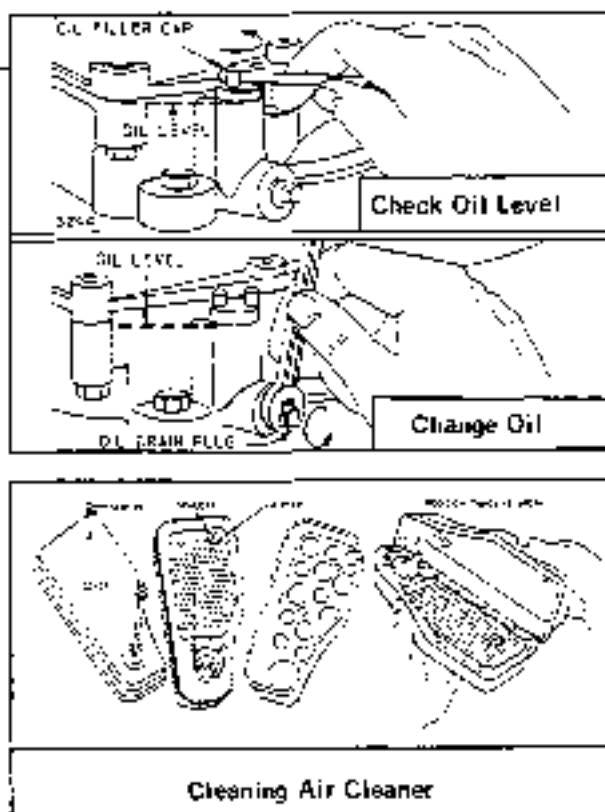

Section
3

MAINTENANCE (cont'd)

- 4 **CLEAN COOLING SYSTEM** — Grass, chaff or dirt may clog the air cooling system, especially after prolonged service cutting dry grasses. To avoid overheating and engine damage, remove the blower housing and clean the area shown. This should be a regular maintenance operation.

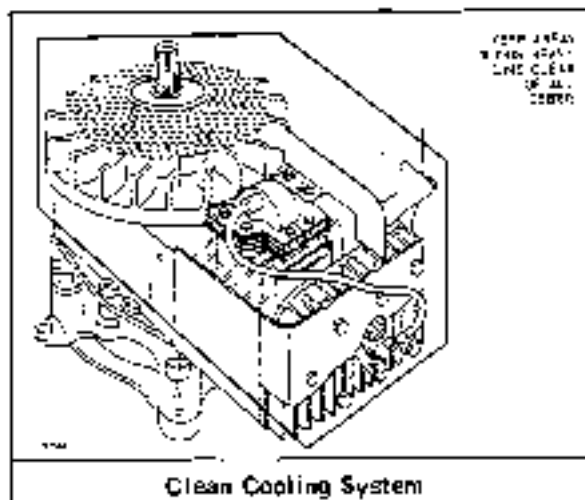

- 5 **CLEAN SPARK PLUG** — Clean and reset gap at .030" every 100 hours of operation. Caution: Blast cleaning of spark plugs in machines that use abrasive grit is not recommended. Spark plugs should be cleaned by scraping or wire brushing and washing with a commercial solvent or gasoline.

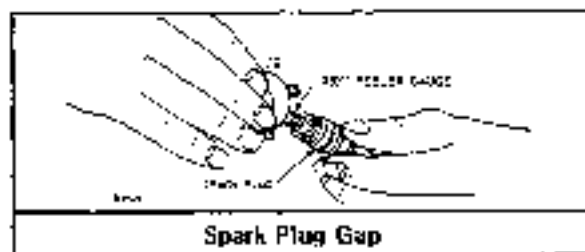

- 6 **CLEAN FUEL SYSTEM** — Drain and clean fuel tank. Unscrew fuel outlet from tank and clean filter.

Section
4

ADJUSTMENTS

CARBURETOR ADJUSTMENTS

Minor carburetor adjustment may be required to compensate for differences in fuel, temperature, altitude and load.

To Adjust Carburetor Turn needle valve clockwise until it just closes. Caution: Valve may be damaged by turning it in too far.

Now open needle valve 1-1/8 turns counterclockwise. Close idle valve in same manner and open 1-1/8 turns. This initial adjustment will permit the engine to be started and warmed up prior to final adjustment.

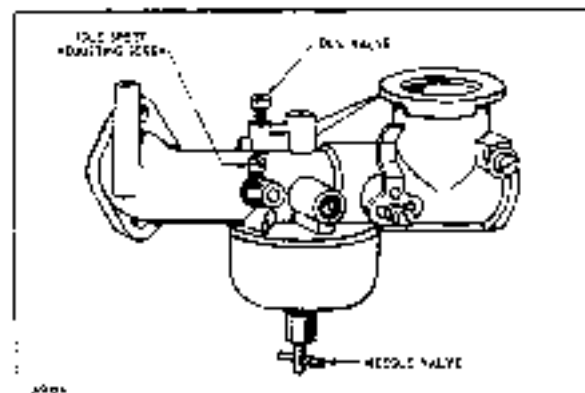

Final Adjustment Turn needle valve in until engine misses (lean mixture). Then turn it out past smooth operating point until engine runs unevenly (rich mixture). Now turn needle valve to the mid-point between rich and lean so the engine runs smoothly. Hold throttle at idle position and set idle speed adjusting screw until fast idle is obtained (1750 RPM). Hold throttle in idle position and turn idle valve in (lean) and out (rich) until engine idles smoothly. Then reset idle speed adjusting screw so that engine idles at 1750 RPM. Release throttle — engine should accelerate without hesitation or sputtering. If engine does not accelerate properly, the carburetor should be re-adjusted to a slightly richer mixture.

Section
4

ADJUSTMENTS (cont'd)

CHOKE-A-MATIC CARBURETOR CONTROLS ADJUSTMENT

Proper choke and stop switch operation is dependent upon proper adjustment of remote controls on the powered equipment.

To Check Operation of Choke-A-Matic Controls:

- Move remote control lever to "Choke" position. The carburetor choke should be closed.
- Move remote control to "Stop" position. Governor control lever should make full contact with stop switch.

To Adjust:

Place remote control lever on equipment in FAST (high speed) position. Loosen control casing clamp screw "C". Move control casing "A" and wire until lever "E" lines up with bottom edge of tang "F". Tighten casing clamp screw "C".

SPEED CONTROL ADJUSTMENTS

The correct operating speed range is 1800 to 3600 RPM. Idle speed is 1750 RPM. There are several types of speed controls on these engines. Select the control on your engine. To increase engine speed move control in direction of arrow.

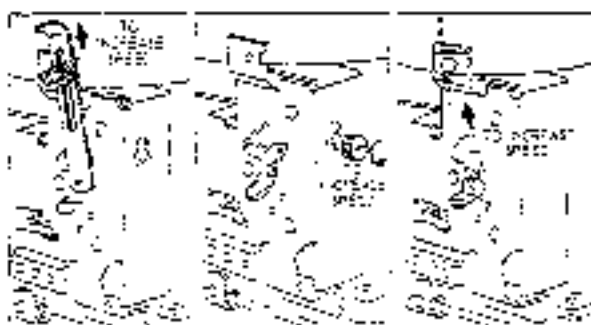
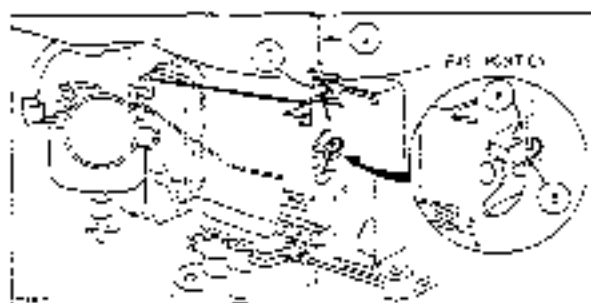

Section
5

GENERAL INFORMATION

These engines are single cylinder, L-head, air-cooled type

MODEL SERIES 146700 to 146707

Bore	2 3/4"
Stroke	2 3/8"
Displacement	14.11 cu. in.
Horsepower	6.0 H.P. max. @ 3600 RPM
Torque (Ft. Lbs.)	9.25 max. @ 2900 RPM

170700 to 170707

Bore	3"
Stroke	2 3/8"
Displacement	16.79 cu. in.
Horsepower	7.0 H.P. max. @ 3600 RPM
Torque (Ft. Lbs.)	11.0 max. @ 2600 RPM

The horsepower ratings listed above are established in accordance with the Society of Automotive Engineers Test Code J807. For practical operation, the horsepower loading should not exceed 85% of these ratings. Engine power will decrease 3% for each 1000 feet above sea level and 1% for each 10° above 60° F.

TUNE-UP SPECIFICATIONS

Spark Plug Type	A.C.	Aurite	Champion
Short Plug	CS-45	A7N	CJ-8
Long Plug	GC-46	A7i	J-8
Spark Plug Gap	.030"		
Ignition Point Gap	.020"		
Intake Valve Clearance	.005" - .007"		
Exhaust Valve Clearance	.009" - .011"		

STORAGE INSTRUCTIONS

Engines to be stored over 30 days should be completely drained of fuel to prevent gum deposits forming on essential carburetor parts, fuel filter, fuel lines and tank.

- Drain fuel tank completely and clean fuel filter.
- Operate engine until gasoline in carburetor is completely consumed.
- While engine is still warm, drain oil from crankcase. Refill with fresh oil.
- Remove spark plug, pour 1 ounce (2 or 3 tablespoons) of SAE-30 oil into cylinder and crank slowly to distribute oil. Replace spark plug.
- Clean dirt and chaff from cylinder head fins and blower housing. (See Section 3).

Briggs & Stratton OPERATING AND MAINTENANCE INSTRUCTIONS MODELS 19D, 19D-FB, 19D-R6

IMPORTANT: Do not start this engine before reading Section I and Section II of this manual.

CAUTION

PROVIDE EFFICIENT VENTILATION Exhaust gases contain carbon monoxide, an odorless and deadly poison. Do not operate engine in an enclosed area.

KEEP ENGINE CLEAN. This engine is air-cooled. If cooling system becomes clogged, serious damage may result. Therefore, keep the blower screen, fins on flywheel, cylinder head and block free from grass or dirt.

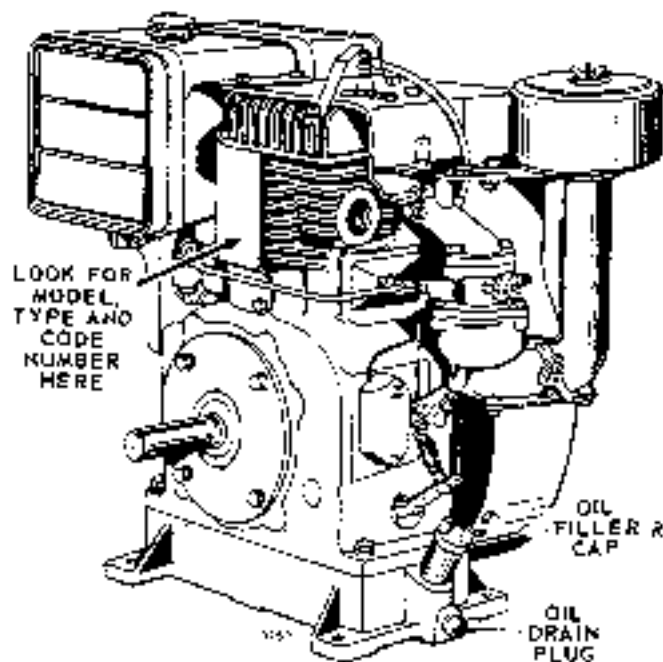

SECTION I

BEFORE STARTING

"OIL-FOAM"[®] AIR CLEANER

"Oil-Foam"[®] air cleaners are oiled at the factory and do not require initial service.

FILL FUEL TANK

Use clean, fresh "regular" grade gasoline. Fill tank completely.

DO NOT FILL GASOLINE TANK WHILE ENGINE IS RUNNING. Avoid spilling gasoline on a hot engine — this may cause an explosion and serious injury.

DO NOT MIX OIL WITH GASOLINE

OIL RECOMMENDATIONS

WINTER
(Below 40° F.)
Use SAE 5W-20
If not Available
Use SAE 10W
Above 10° F.

SUMMER
(Above 40° F.)
Use SAE 30
If not Available
Use SAE 10W-30

Nothing should be added to the recommended oils.

FILL CRANKCASE WITH OIL



Remove the oil filler plug. Place the engine level. Fill the crankcase to overflowing. **POUR SLOWLY.** CAPACITY 3 PINTS. Replace the filler plug.

Any high quality detergent oil having the American Petroleum Institute classification "For Service MS" can be used in your Briggs & Stratton engine. Detergent oils keep the engine cleaner and retard the formation of gum and varnish deposits.

SECTION II STARTING

TO START ENGINE

1. Open Fuel Valve

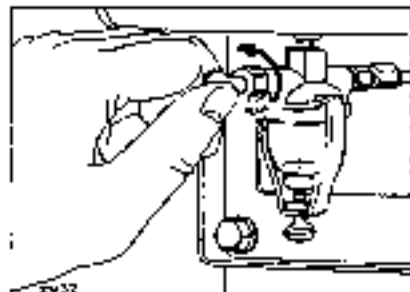

2. Close the Choke



3. Start Engine

a. Rope Starter

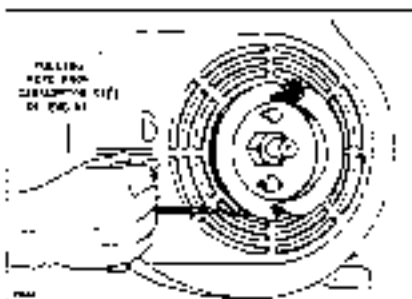

Place knot in pulley notch and wind rope around pulley in a clockwise direction. Pull rope with choke closed to prime the engine. Open choke slightly and repeat operation.

After engine warms up open choke gradually until engine runs smoothly with choke wide open (counterclockwise position).

b. 12 Volt D.C. Electric Starter

Press starter button on powered equipment. When engine starts, open choke gradually.

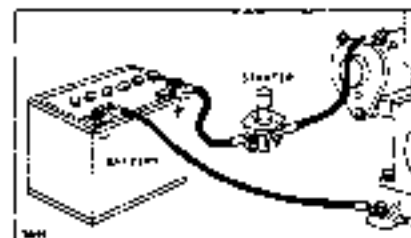

STOPPING

To Stop Engine

Push the stop switch against end of spark plug.

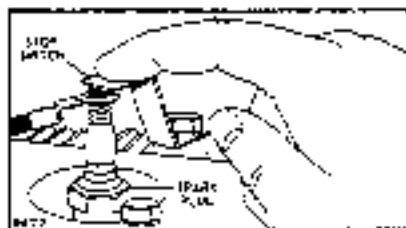

SECTION III REGULAR MAINTENANCE

CHANGE OIL (Crankcase)

Change oil after 5 hours of operation. Remove the oil drain plug. Drain oil while engine is warm. Replace drain plug. Remove oil filler cap or plug and refill with new oil. Replace oil filler cap or plug. Add oil regularly after each 5 hours of operation. Thereafter change oil every 25 hours of operation.

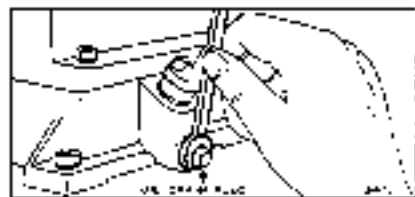

CHANGE OIL (Gear Reduction)

The reduction gears are lubricated by engine crankcase oil. Remove drain plug from gear case cover to drain oil remaining in gear case when crankcase oil is changed.

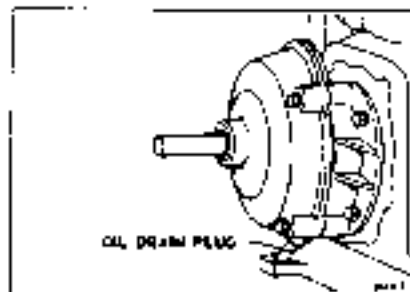

TO CHECK SPARK PLUG GAP

Clean spark plug and reset gap at .025" every 100 hours of operation. When worn out replace with AC GC 46, Autolite A71 or Champion J-8. Size 14 mm.

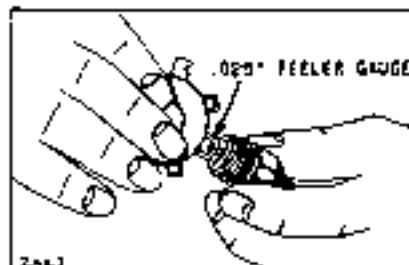

SERVICING "OIL-FOAM"® AIR CLEANER

Clean and re-oil the air cleaner frequently (every few hours under extremely dusty conditions). Clean and re-oil at least every 25 hours under normal conditions.

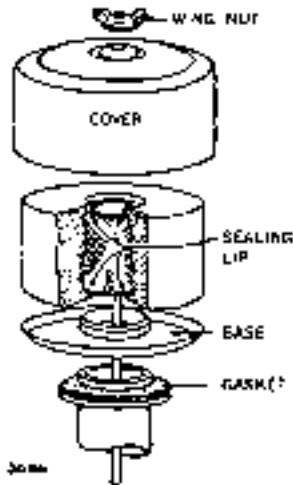

1. Remove wing nut and cover.
2. Lift off foam element from base.
3. Push down foam element as shown and pull out screen.

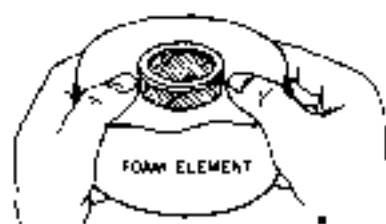

4. A - Wash foam element in kerosene or solvent.
- B - Squeeze dry and re-oil with 6 tablespoons engine oil.
- C - Squeeze again to spread oil through foam element.
- D - Put screen inside element. Be sure sealing lip is over end of screen (top and bottom).
5. Reassemble parts as shown. Fasten to engine. Screw wing nut down tight.

DRAINING FUEL TANK AND CLEANING FUEL FILTER

Loosen thumb screw below filter bowl.

Remove and clean filter bowl and screen.

Open shut-off valve to see if fuel flows freely from the tank. **IMPORTANT:** If you find a gummy, varnish-like substance use alcohol or acetone to dissolve it.

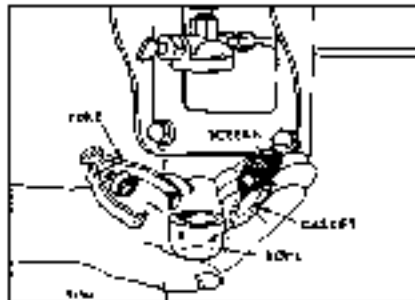

CLEAN COOLING SYSTEM

Grass or chaff may clog cooling system after prolonged service in cutting tall dry grasses or hay. Continued operation with a clogged cooling system causes severe overheating and possible engine dam-

age. Remove blower housing and clean regularly.

TO CLEAN AND ADJUST CONTACT POINTS

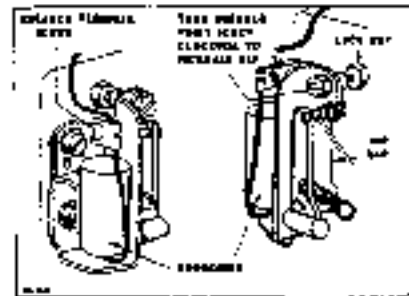

Remove cover.

Clean points with a carborundum contact point stone. Then insert a hard finished card or piece of paper and close and open points. The paper will absorb any dirt or filings on the points. Adjust breaker points as follows:

- a. Rotate crankshaft until points open to widest gap.
- b. Loosen lock nut illustrated above until it is just snug.

c. Rotate breaker point screw to obtain .020" gap.

d. When gap is .020" tighten lock nut.

e. Replace breaker box cover.

CLEAN COMBUSTION CHAMBER EVERY 100-300 HOURS OF OPERATION

This industrial engine generally operates at constant speed and at relatively constant load. The use of regular automotive fuels under these conditions results in a gradual build-up of tetra-ethyl lead deposits in the combustion chamber.

This causes the engine to lose power and prevents the valves from seating properly. Removing the deposits is easy and will pay big dividends in reliability and increased valve life.

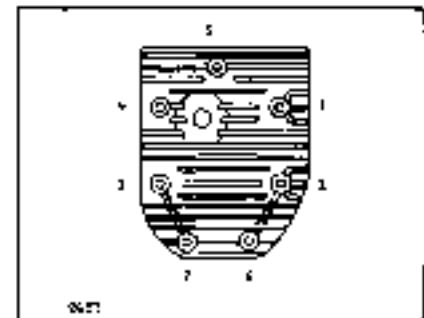

1. Remove cylinder head screws. Be sure to note if screws are of different length and have steel washers as they must be replaced in original position.

2. Turn crankshaft until piston is at top of cylinder bore and both valves are closed. Scrape and wire brush the lead and carbon deposits from cylinder head and combustion chamber.

3. Re-use cylinder head gasket only if in good condition. Replace cylinder head. Turn each screw in with wrench until screw head is lightly seated.

4. Use socket wrench with 6 inch handle and turn all screws 1/4 turn. Tighten screws in sequence illustrated. Run engine approximately 5 minutes and re-tighten all screws approximately 1/4 turn.

SECTION IV ADJUSTMENTS

CARBURETOR ADJUSTMENTS

Initial Adjustment

Turn needle valve clockwise until it just closes: **CAUTION:** Valve may be damaged by turning it in too far.

Now open needle valve 1-1/2 turns counterclockwise.

Close idle valve in same manner and open it 1/2 to 3/4 turns. This initial adjustment will permit the engine to be started and warmed up prior to final adjustment.



Final Adjustment

Turn needle valve in until engine misses (lean mixture), then turn it out past smooth operating point until engine runs unevenly (rich mixture). Now turn needle valve to the mid-point between rich and lean so the engine runs smoothly.

Hold throttle at idle position, set idle speed adjusting screw until fast idle is obtained (1200 RPM). Hold throttle in idle position and turn idle valve in (lean) and out (rich) until engine idles smoothly. Then reset idle speed so that engine idles at 1200 RPM. Release throttle—engine should accelerate without hesitation or sputtering. If engine does not accelerate properly, re-adjust carburetor to a slightly richer mixture.

GOVERNOR ADJUSTMENTS

The correct operating speed range is 1800 to 3600 RPM. The standard speed setting (no load) is 2900 RPM. Idle speed is 1200 RPM.

Thumb Nut Adjustment

To increase speed, turn nut (clockwise) or move lower end of governor spring farther away from governor lever shaft.

To reduce speed, turn nut counterclockwise) or move lower end of spring closer to governor lever shaft.

If the speed of the engine is not steady although the carburetor has been properly adjusted, move the spring farther away from the governor lever shaft.

If the speed variation between no load and full load is too great, move spring closer to governor lever shaft.

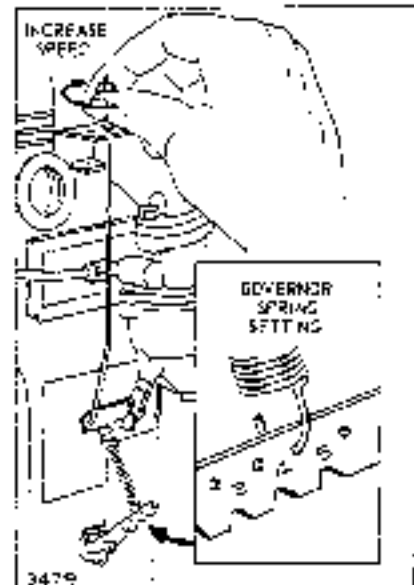

REMOTE GOVERNOR CONTROL

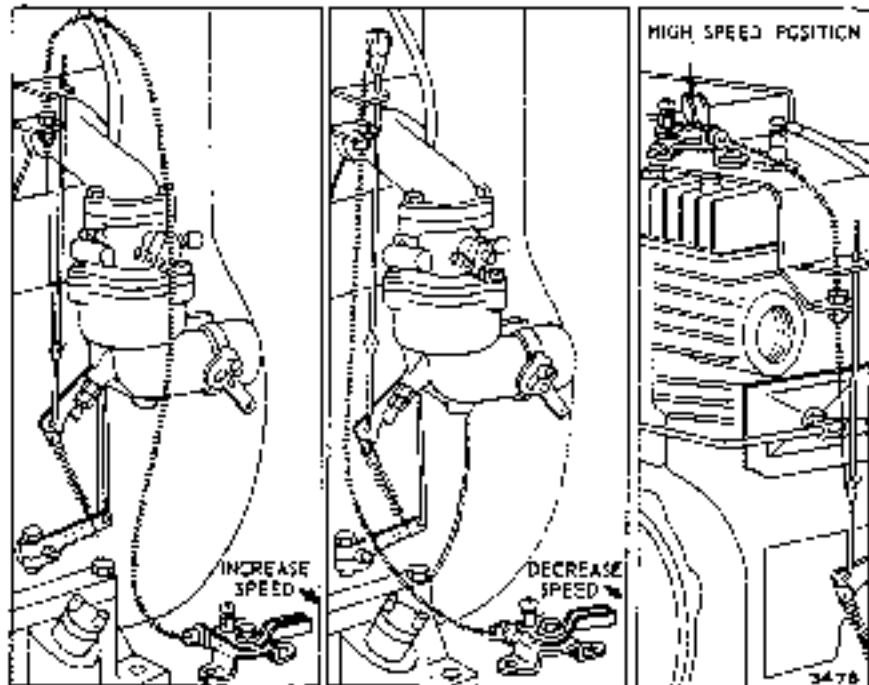

Engine speed is controlled by movement of the control lever. To adjust: Move control lever to HIGH speed position. Loosen screw on swivel. Move wire through swivel until desired operating speed is obtained. Retighten swivel screw, bend loose end of wire around swivel. Cut off excess wire. Be sure to remove or loosen thumb screw on governor control rod.

SECTION V
GENERAL INFORMATION

These engines are single cylinder, L-Head, air-cooled type

Bore - 3", Stroke - 2 5/8"; Displacement - 18.56 cu. in.; Horsepower: -

3.65 h.p. at 1800 r.p.m.	5.45 h.p. at 2400 r.p.m.
6.70 h.p. at 3000 r.p.m.	7.25 h.p. at 3600 r.p.m.

Torque (Ft.-Lbs.)	11.95 at 2400 RPM
Intake Valve Clearance007" - .009"
Exhaust Valve Clearance017" - .019"

The horsepower ratings listed above are established by standard C.E.3, procedures. For practical operation, the horsepower loading should not exceed 85% of these ratings. Engine power will decrease 3 1/2% for each 1,000 ft. above sea level and 1% for each 10 degrees above 60 degrees F.

Major engine repairs should not be attempted unless you have the proper tools and a thorough knowledge of internal combustion engines.

STORAGE INSTRUCTIONS

Engines stored for over 30 days should be completely drained of fuel to prevent gum deposits forming on essential carburetor parts, fuel filter, fuel lines and tank.

- a. Remove filter bowl, open shut-off valve and drain tank completely.
- b. Replace filter bowl. Leave fuel valve open.
- c. Operate engine until it stops from lack of fuel.
- d. While engine is still warm, drain and clean the oil sump. Refill with fresh oil.
- e. Remove spark plug, pour one ounce of SAE 30 oil into cylinder and crank slowly to spread oil. Replace spark plug.
- f. Clean dirt and chaff from cylinder, cylinder head fins and blower housing.

MODEL 243431

Section 1

BEFORE STARTING

READ THE OPERATING INSTRUCTIONS OF
THE EQUIPMENT THIS ENGINE POWERS

- 1 **FILL CRANKCASE WITH OIL** — Use a high quality detergent oil classified "For Service BC or SD or MS". Nothing should be added to the recommended oil.

SUMMER
(Above 40° F.)
Use SAE 30

If not available,
Use SAE 10W-30
or
SAE 10W-40

WINTER
(Under 40° F.)
Use SAE 5W-20 or SAE 5W-30

If not available,
Use SAE 10W or SAE 10W-30
Below 0° F.
Use SAE 10W or SAE 10W-30
Diluted 10% with Kerosene

DIRECTIONS: Place the engine level. Remove oil filler plug or Oil-Vinder. **FILL THE OIL SUMP TO OVERFLOWING** or to the **FULL** mark on dipstick. Pour slowly. Capacity 4 pints.

EXTENDED OIL FILL. (Optional) Remove cap and dipstick. When checking oil level push dipstick assembly firmly but slowly until cap bottoms on tube. **Do not overfill.** Dipstick assembly must be pushed fully into tube at all times when engine is operating.

- 2 **FILL FUEL TANK** — Use clean, fresh, lead-free or leaded "regular" grade automotive gasoline. **Fill tank completely!**

DO NOT MIX OIL WITH GASOLINE.

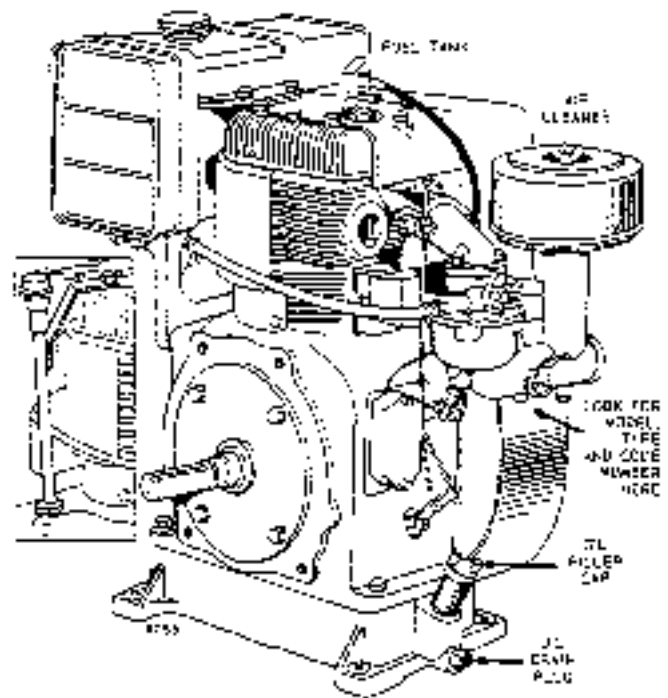

1 OPEN FUEL VALVE

CAUTION: ALWAYS KEEP HANDS AND FEET CLEAR OF MOWER BLADE OR OTHER ROTATING MACHINERY.

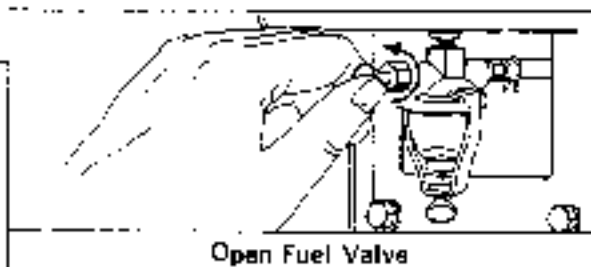

2 CLOSE THE CHOKE - Engine may be equipped with manual or remote choke.

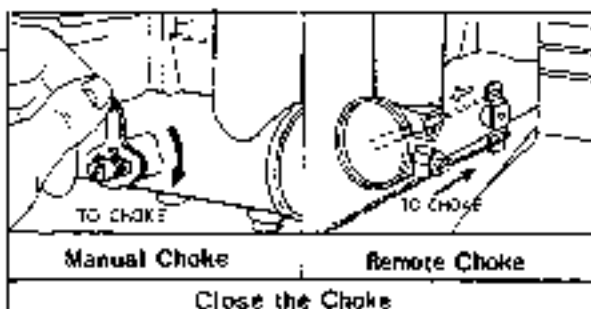

3 START ENGINE - Engine may be equipped with rope or electric starter.

a. Rope Starter

Place knot in pulley notch and wind rope around pulley in a clockwise direction. Pull rope with choke closed to prime the engine. Open choke slightly and repeat operation.

After engine warms up open choke gradually until engine runs smoothly with choke wide open (counter-clockwise position).

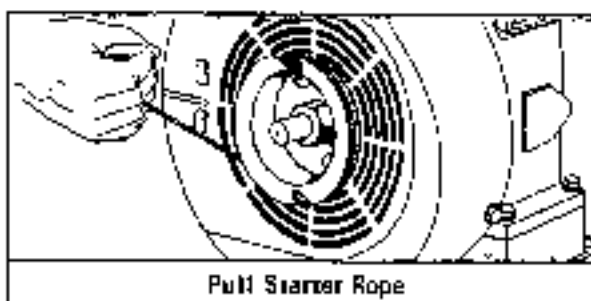

b. 12 Volt D.C. Electric Starter

Press starter button on powered equipment. When engine starts, open choke gradually.

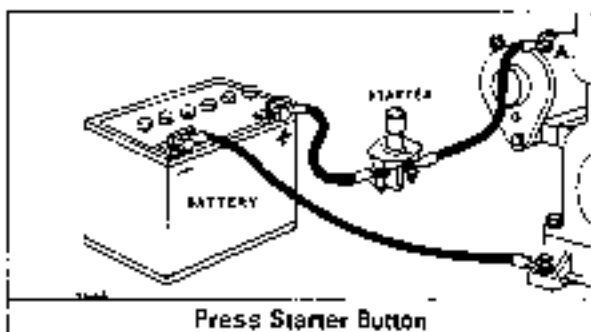

4 TO STOP ENGINE

Push the stop switch against end of spark plug, or turn off ignition switch on equipment.

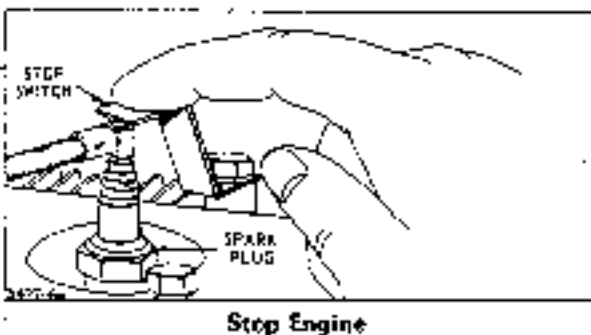

Section
3

MAINTENANCE

1 CHECK OIL LEVEL

Check before starting and after every 5 hours of operation. BE SURE OIL LEVEL IS MAINTAINED.

2 CHANGE OIL (Crankcase)

Change oil after first 5 hours of operation. Thereafter change oil every 25 hours of operation. Remove the oil drain plug. Drain oil while engine is warm. Remove oil filler cap or plug and refill with new oil. Replace oil filler cap or plug. Add oil regularly after each 5 hours of operation.

3 SERVICING HEAVY DUTY AIR CLEANER

Clean and re-oil foam pre-cleaner at 3 month intervals or every 25 hours, whichever occurs first.

1. Remove wing nut and cover.
2. Remove foam pre-cleaner element by sliding it up off of the paper cartridge.
3. A - Wash foam in liquid detergent and water.
B - Squeeze dry.
C - Oil with one ounce engine oil. Squeeze to distribute oil evenly.
4. Assemble to paper cartridge. Reassemble cover and wing nut. Screw wing nut down tight.

Yearly or every 100 hours, whichever occurs first, remove paper cartridge. Clean by tapping gently on flat surface. If very dirty, replace cartridge, or wash in liquid detergent and water. Rinse until water remains clear. Cartridge must be air dried thoroughly before using.

NOTE: Service more often under dusty conditions.

4 CLEAN COOLING SYSTEM

Grass or chaff may clog cooling system after prolonged service in cutting dry grasses or hay. Continued operation with a clogged cooling system causes severe overheating and possible engine damage. Remove blower housing and clean regularly.

5 CLEAN COMBUSTION CHAMBER every 100-300 hours of operation. If the engine operates at constant speed and at relatively constant load, the use of regular automotive fuels results in a gradual build-up of lead deposits in the combustion chamber.

This causes the engine to lose power and prevents the valves from seating properly. Removing the deposits is easy and will pay big dividends in reliability and increased valve life.

1. Remove cylinder head screws.
2. Turn crankshaft until piston is at top of cylinder bore and both valves are closed. Scrape and wire brush the lead and carbon deposits from cylinder head and combustion chamber.
3. Re-use cylinder head gasket only if in good condition. Replace cylinder head. Turn each screw in with wrench until screw head is lightly seated.
4. Use socket wrench with 6 inch handle and turn all screws 1/4 turn. Tighten screws in sequence illustrated. Run engine approximately 5 minutes and re-tighten all screws approximately 1/4 turn.

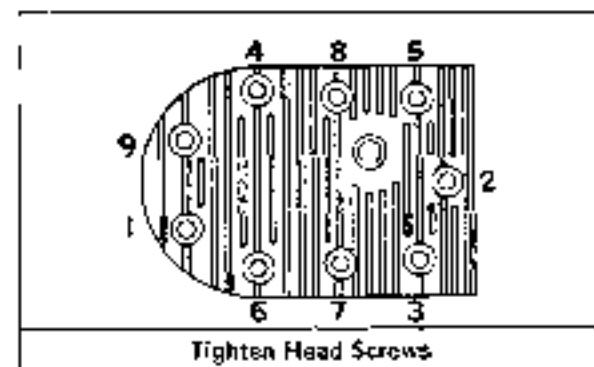
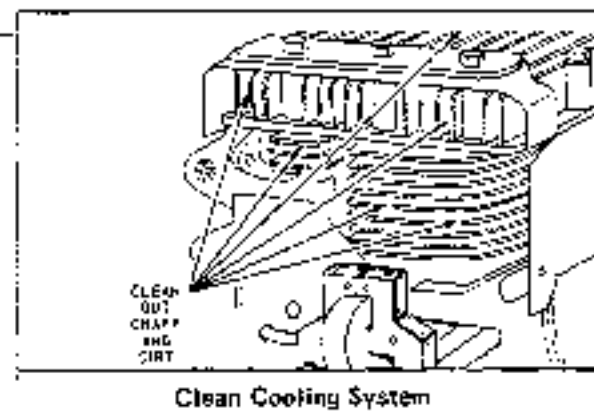
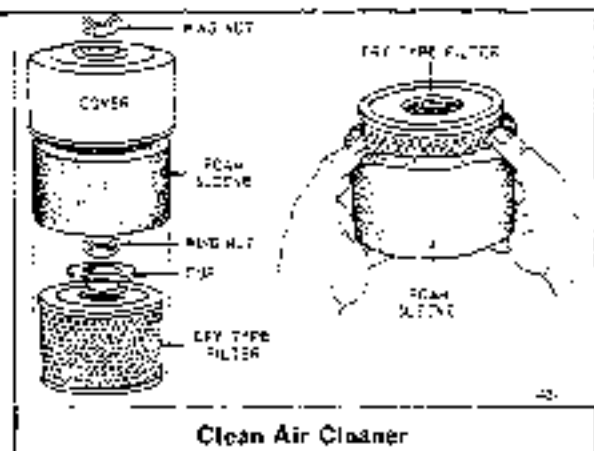
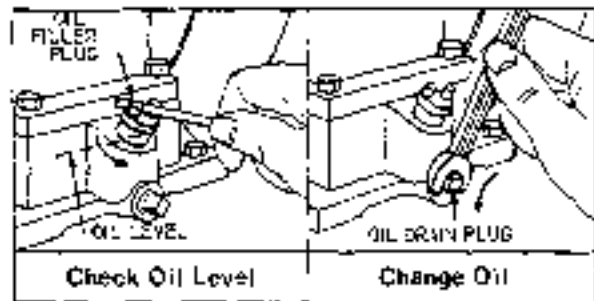

Section
3

MAINTENANCE (cont'd)

6 CLEAN AND ADJUST CONTACT POINTS

Remove cover. Clean points with a carborundum contact point stone. Then insert a hard finished card or piece of paper and close and open points. The paper will absorb any dirt or filings on the points. Adjust breaker points as follows:

- Rotate crankshaft until points open to widest gap.
- Loosen lock nut illustrated below until it is just snug.
- Rotate breaker point screw to obtain .020" gap.
- When gap is .020" tighten locknut.
- Replace breaker box cover.

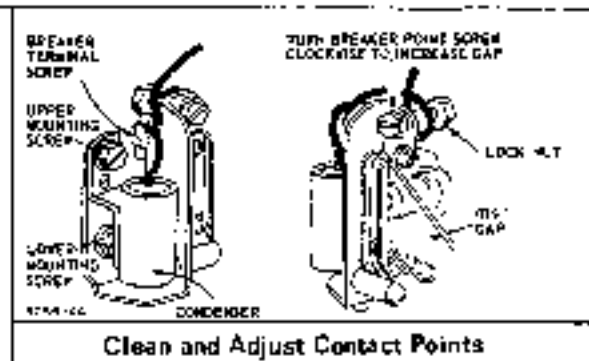

7 CLEAN SPARK PLUG - Clean and reset gap at .030" every 100 hours of operation.

CAUTION: Just cleaning of spark plugs in machines that use abrasive grit is not recommended. Spark plugs should be cleaned by scraping or wire brushing and washing with a commercial solvent or gasoline.

8 DRAIN FUEL TANK AND CLEAN FUEL FILTER

Loosen thumb screw below filter bowl. Remove and clean filter bowl and screen. Open shut-off valve to see if fuel flows freely from the tank. **IMPORTANT:** If you find a gummy, varnish-like substance use alcohol or acetone to dissolve it.

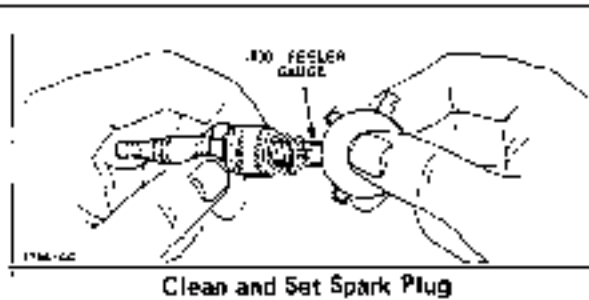

Section
4

ADJUSTMENTS

CARBURETOR ADJUSTMENTS

Minor carburetor adjustment may be required to compensate for differences in fuel, temperature, altitude and load.

Initial Adjustment

Turn needle valve clockwise until it just closes. - **CAUTION:** Valve may be damaged by turning it in too far.

Now open needle valve 1-1/2 turns counterclockwise. Close idle valve in same manner and open it 1/2 to 3/4 turns. This initial adjustment will permit the engine to be started and warmed up prior to final adjustment.

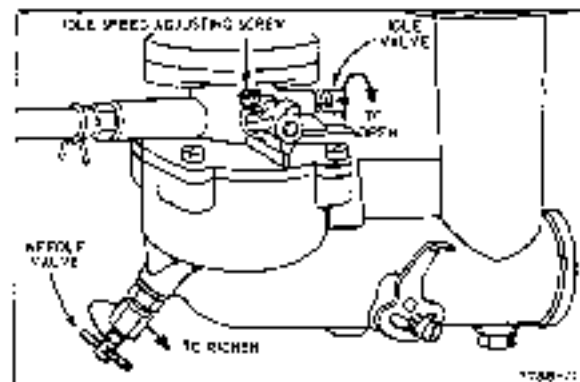

Final Adjustment: Turn needle valve in until engine misses (lean mixture), then turn it out past smooth operating point until engine runs unevenly (rich mixture). Now turn needle valve to the mid-point between rich and lean so the engine runs smoothly. Hold throttle at idle position, set idle speed adjusting screw until fast idle is obtained (1200 RPM). Hold throttle in idle position and turn idle valve in (lean) and out (rich) until engine idles smoothly. Then reset idle speed so that engine idles at 1200 RPM. Release throttle -- engine should accelerate without hesitation or sputtering. If engine does not accelerate properly, re-adjust needle valve to a slightly richer mixture.

Section
4

ADJUSTMENTS (cont'd)

GOVERNOR SPEED ADJUSTMENTS

The governor controls the engine speed from idle through the full operating range. Idle speed should be no lower than 1000 RPM and top no load speed should be no higher than 3800 RPM. See illustration to adjust governor.

Governed Idle Speed Adjustment

The shorter spring keeps the engine on governor, even at idle speed. If moderate loads are applied at idle the engine will not stall.

First make final carburetor mixture adjustments. Then place remote control in idle position. Hold throttle shaft in closed position and adjust idle speed screw to 1000 RPM. Release the throttle. With remote control in idle position, adjust upper elastic stop nut to 1200 RPM.

REMOTE SPEED CONTROL ADJUSTMENT

Engine speed is controlled by movement of the control lever. To adjust: Move control lever to HIGH speed position. Loosen screw on swivel. Move wire through swivel until desired operating speed is obtained. Retighten swivel screw, bend loose end of wire around swivel. Cut off excess wire.

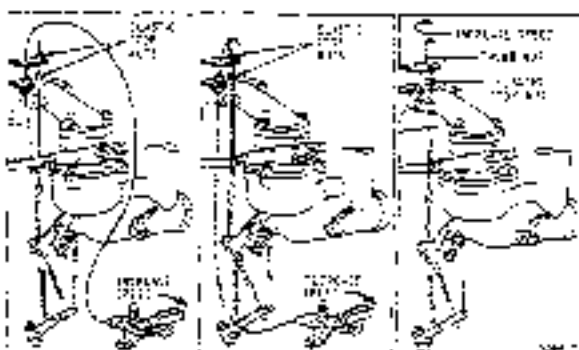

Section
5

GENERAL INFORMATION

These engines are single cylinder, L-head, air-cooled type

Model Series 243431 to 243434

Bore	3 1/16"
Stroke	3 1/4"
Displacement	23.84 cu. in.
Horsepower	10.0 max. @ 3600 RPM
Torque (Ft. Lbs.)	16.75 max. @ 2400 RPM

The horsepower ratings listed above are established in accordance with the Society of Automotive Engineers Test Code-J607. For practical operation, the horsepower loading should not exceed 85% of these ratings. Engine power will decrease 3 1/2% for each 1000 feet above sea level and 1% for each 10° above 60° F.

TUNE-UP SPECIFICATIONS

Spark Plug Type	A.C.	Aurorite	Champion
Short Plug	C5-45	A7N	CJ-8
Long Plug	GC-46	A7T	J-3
Spark Plug Gap	.030"		
Ignition Point Gap	.020"		
Intake Valve Clearance	.007"-.009"		
Exhaust Valve Clearance	.017"-.019"		

STORAGE INSTRUCTIONS

Engines stored for over 30 days should be completely drained of fuel to prevent gum deposits forming on essential carburetor parts, fuel filter, fuel lines and tank.

- Remove filter bowl, open shut-off valve and drain tank completely.
- Replace filter bowl. Leave fuel valve open.
- Operate engine until it stops from lack of fuel.
- While engine is still warm, drain and clean the oil sump. Refill with fresh oil.
- Remove spark plug, pour one ounce of SAE 30 oil into cylinder and crank slowly to spread oil. Replace spark plug.
- Clean dirt and chaff from cylinder, cylinder head fins and blower housing.

Major engine repairs should not be attempted unless you have the proper tools and a thorough knowledge of internal combustion engines.

MODEL 300401

Section I BEFORE STARTING

READ THE OPERATING INSTRUCTIONS OF THE EQUIPMENT THIS ENGINE POWERS

- ① **FILL CRANKCASE WITH OIL** - Use a high quality detergent oil classified "For Service MS". Nothing should be added to the recommended oil.

Summer - (Over 40° F) Use SAE 30 Oil

Winter - (Under 40° F) Use SAE SW-20
If not available Use SAE 10W
(Below 0° F) Use SAE 10W
diluted with 10% kerosene

DIRECTIONS: Place the engine level. Remove oil filler plug or Oil Minder. **FILL THE OIL SUMP TO OVERFLOWING** or to the **FULL** mark on dipstick. Pour slowly. Capacity 4 pnts.

EXTENDED OIL FILL. (Optional). Remove cap and dipstick. When checking oil level push dipstick assembly firmly but slowly until cap bottoms on tube. Do not overfill. Dipstick assembly must be pushed fully into tube at all times when engine is operating.

- ② **FILL FUEL TANK** - Use clean, fresh, leaded or non-leaded "REGULAR" grade automotive gasoline. Fill tank completely

DO NOT MIX OIL WITH GASOLINE.

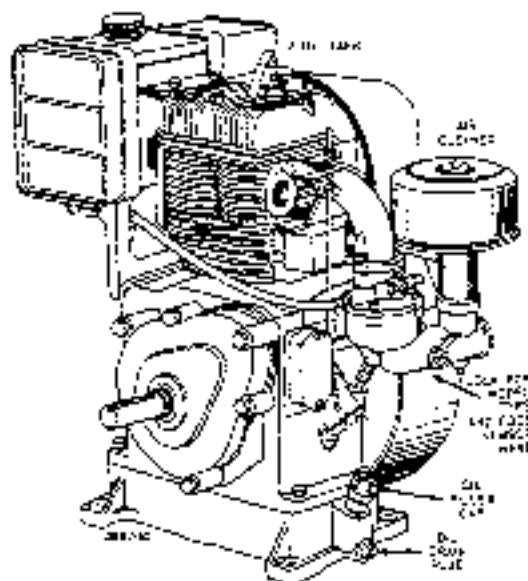

1 OPEN FUEL VALVE

CAUTION: ALWAYS KEEP HANDS AND FEET CLEAR OF MOWER BLADE OR OTHER ROTATING MACHINERY.

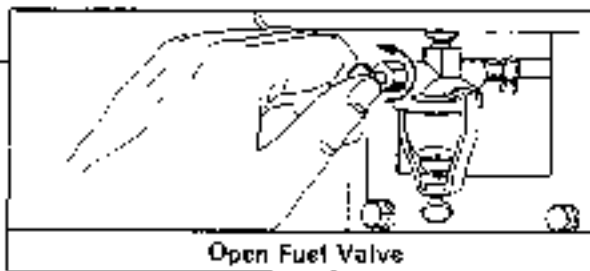

2 CLOSE THE CHOKE — Engine may be equipped with manual or remote choke.

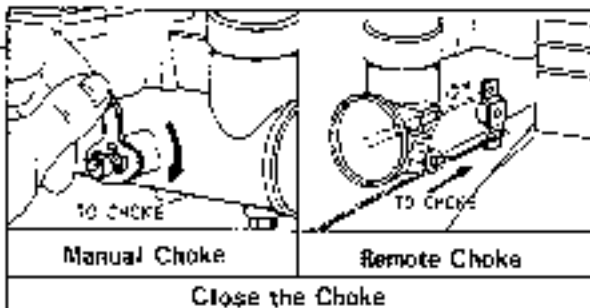

3 START ENGINE — Engine may be equipped with rope or electric starter

a. Rope Starter

Place knot in pulley notch and wind rope around pulley in a clockwise direction. Pull rope with choke closed to prime the engine. Open choke slightly and repeat operation.

After engine warms up open choke gradually until engine runs smoothly with choke wide open (counter-clockwise position).

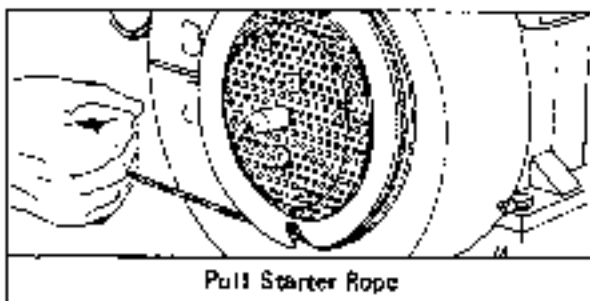

b. 12 Volt D.C. Electric Starter

Press starter button on powered equipment. When engine starts, open choke gradually.

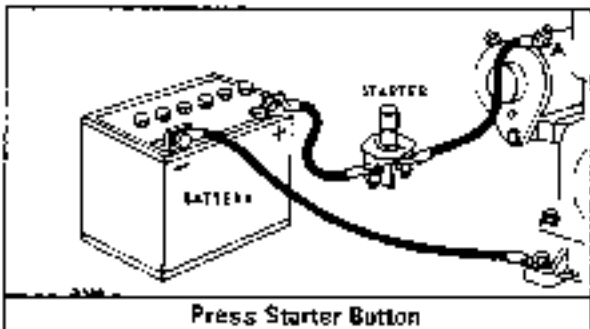

4 TO STOP ENGINE

Push the stop switch against end of spark plug or turn off ignition switch on equipment.

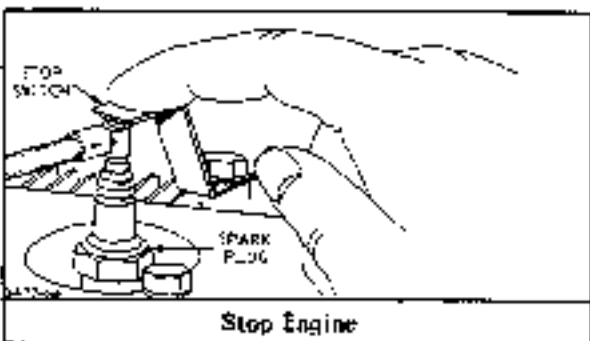

1 CHECK OIL LEVEL

Check before starting and after every 5 hours of operation. BE SURE OIL LEVEL IS MAINTAINED.

2 CHANGE OIL (Crankcase)

Change oil after first 5 hours of operation. Thereafter change oil every 25 hours of operation. Remove the oil drain plug. Drain oil while engine is warm. Remove oil filler cap or plug and refill with new oil. Replace oil filler cap or plug. Add oil regularly after each 5 hours of operation.

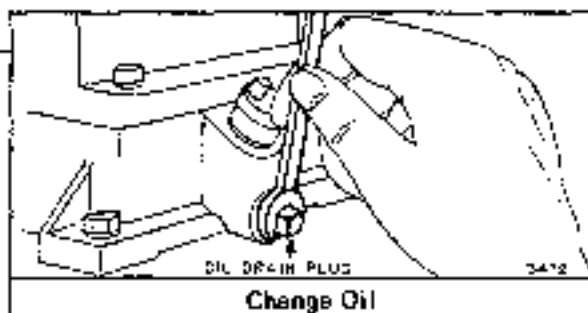

Change Oil

3 SERVICING "OIL-FOAM" & AIR CLEANER

Clean and re-oil the air cleaner frequently (every few hours under extremely dusty conditions); Clean and re-oil at least every 25 hours under normal conditions.

1. Remove wing nut and cover.
2. Lift off foam element from base.
3. Push down foam element as shown, and pull out air cleaner cup.
4. A - Wash foam element in kerosene or liquid detergent and water to remove dirt.
B - Wrap foam in cloth and squeeze dry.
C - Saturate foam in engine oil. Squeeze to remove excess oil.
D - Put air cleaner cup inside element. Be sure sealing lip is over end of cup (top and bottom).
5. Reassemble parts as shown. Screw wing nut down tight.

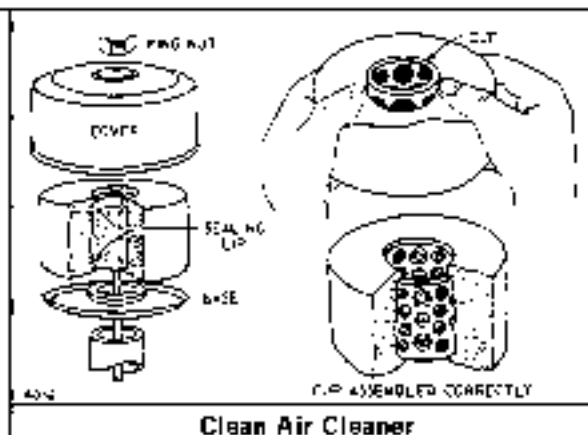

Clean Air Cleaner

4 CLEAN COOLING SYSTEM

Grass or chaff may clog cooling system after prolonged service in cutting dry grasses or hay. Continued operation with a clogged cooling system causes severe overheating and possible engine damage. Remove blower housing and clean regularly.

5 CLEAN COMBUSTION CHAMBER every 100-300 hours of operation. If the engine operates at constant speed and at relatively constant load, the use of regular automotive fuels results in a gradual build-up of lead deposits in the combustion chamber.

This causes the engine to lose power and prevents the valves from seating properly. Removing the deposits is easy and will pay big dividends in reliability and increased valve life.

1. Remove cylinder head screws.
2. Turn crankshaft until piston is at top of cylinder bore and both valves are closed. Scrape and wire brush the lead and carbon deposits from cylinder head and combustion chamber.
3. Re-use cylinder head gasket only if in good condition. Replace cylinder head. Turn each screw in with wrench until screw head is lightly seated.
4. Use socket wrench with 6 inch handle and turn 1 screws 1/4 turn. Tighten screws in sequence illustrated. Run engine approximately 5 minutes and re-tighten all screws approximately 1/4 turn.

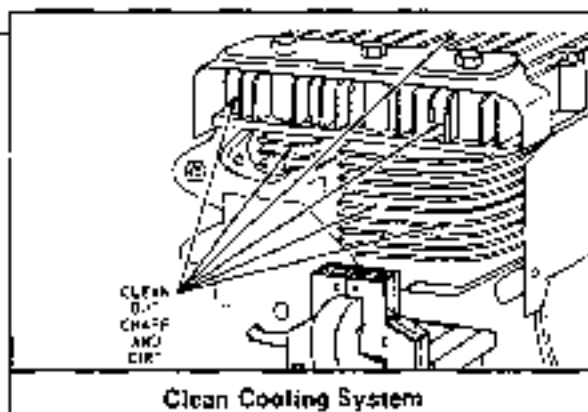

Clean Cooling System

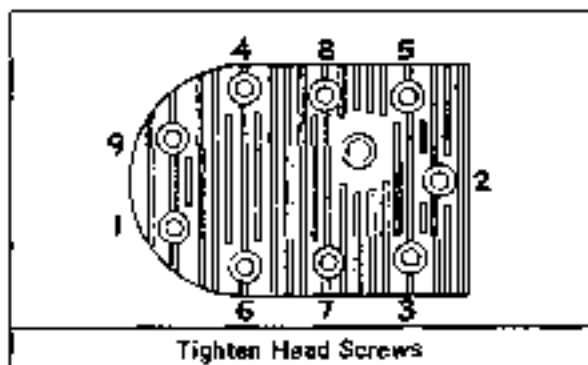

Tighten Head Screws

Section
3

MAINTENANCE (cont'd)

6 CLEAN AND ADJUST CONTACT POINTS

Remove cover. Clean points with a carborundum contact point stone. Then insert a hard finished card or piece of paper and close and open points. The paper will absorb any dirt or filings on the points. Adjust breaker points as follows:

- Rotate crankshaft until points open to widest gap.
- Loosen lock nut illustrated below until it is just snug.
- Rotate breaker point screw to obtain .020" gap.
- When gap is .020" tighten locknut.
- Replace breaker box cover.

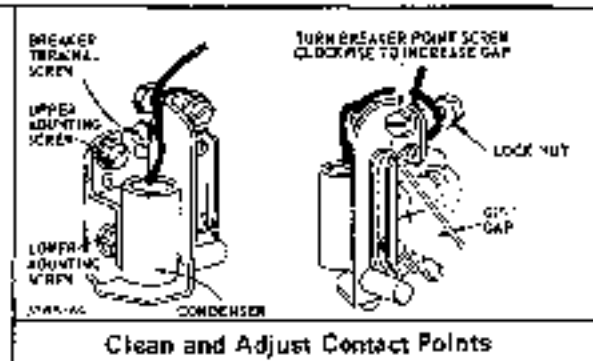

7 CLEAN SPARK PLUG - Clean and reset gap at .030" every 100 hours of operation.

CAUTION: Blast cleaning of spark plugs in machines that use abrasive grit is not recommended. Spark plugs should be cleaned by scraping or wire brushing and washing with a commercial solvent or gasoline.

8 DRAIN FUEL TANK AND CLEAN FUEL FILTER

Loosen thumb screw below filter bowl. Remove and clean filter bowl and screen. Open shut-off valve to see if fuel flows freely from the tank. **IMPORTANT:** If you find a gummy, varnish-like substance use alcohol or acetone to dissolve it.

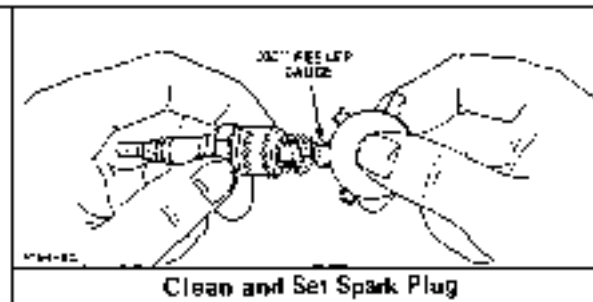

Section 4 ADJUSTMENTS

CARBURETOR ADJUSTMENTS

Minor carburetor adjustment may be required to compensate for differences in fuel, temperature, altitude and load.

Initial Adjustment

Turn needle valve clockwise until it just closes. - **CAUTION:** Valve may be damaged by turning it in too far.

Now open needle valve 1-1/2 turns counterclockwise. Close idle valve in same manner and open it 1/2 to 3/4 turns. This critical adjustment will permit the engine to be started and warmed up prior to final adjustment.

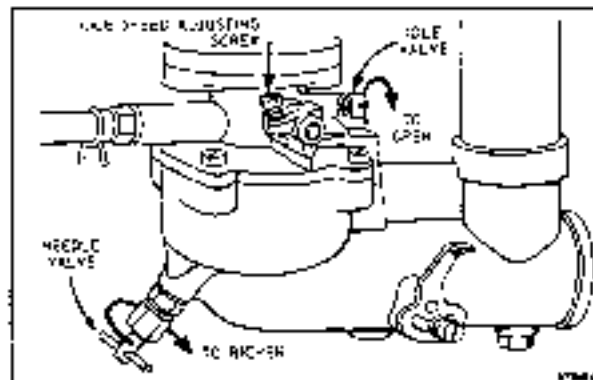

Final Adjustment Turn needle valve in until engine misses (lean mixture), then turn it out past smooth operating point until engine runs unevenly (rich mixture). Now turn needle valve to the mid-point between rich and lean so the engine runs smoothly. Hold throttle at idle position, set idle speed adjusting screw until fast idle is obtained (1200 RPM). Hold throttle in idle position and turn idle valve in (lean) and out (rich) until engine idles smoothly. Then reset idle speed so that engine idles at 1200 RPM. Release throttle - engine should accelerate without hesitation or sputtering. If engine does not accelerate properly, re-adjust needle valve to a slightly richer mixture.

**Section
4**

ADJUSTMENTS

(cont'd)

GOVERNOR SPEED ADJUSTMENTS

The governor controls the engine speed from idle through the full operating range. Idle speed should be no lower than 1000 RPM and top no load speed should be no higher than 3800 RPM. See illustration to adjust governor.

Governed Idle Speed Adjustment

The shorter spring keeps the engine on governor, even at idle speed. If moderate loads are applied at idle, the engine will not stall.

First make final carburetor mixture adjustments. Then place remote control in idle position. Hold throttle shaft in closed position and adjust idle speed screw to 1000 RPM. Release the throttle. With remote control in idle position, adjust upper elastic stop nut to 1200 RPM.

REMOTE SPEED CONTROL ADJUSTMENT

Engine speed is controlled by movement of the control lever. To adjust: Move control lever to HIGH speed position. Loosen screw on swivel. Move wire through swivel until desired operating speed is obtained. Retighten swivel screw, bend loose end of wire around swivel. Cut off excess wire.

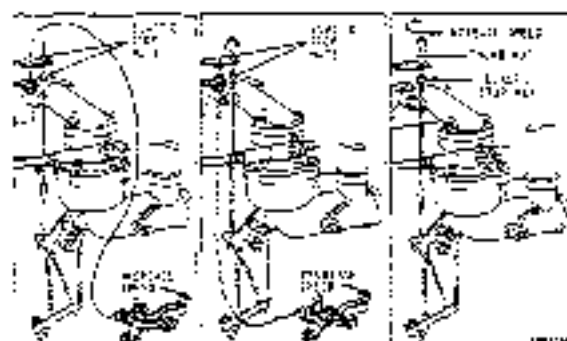
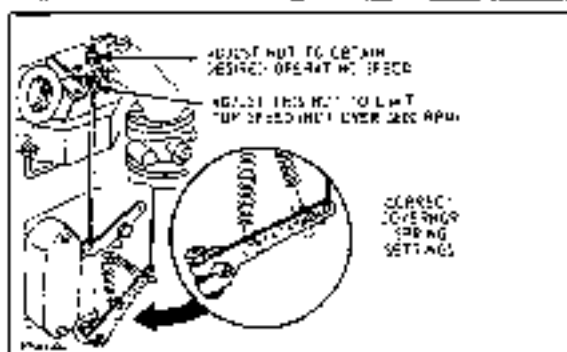

**Section
5**

GENERAL INFORMATION

These engines are single cylinder, L-head, air-cooled type

	MODEL SERIES	
	300401 to 300427	
Bore	3-7/16"	
Stroke	3-1/4"	
Displacement	30.16 cu. in.	
Horsepower	12.0 H.P. max. @ 3600 RPM	
Torque (Ft. Lbs.)	21.1 max. @ 2800 RPM	

	320401 to 320427	
Bore	3-9/16"	
Stroke	3-1/4"	
Displacement	32.4 cu. in.	
Horsepower	14.0 H.P. max. @ 3600 RPM	
Torque (Ft. Lbs.)	23.85 max. @ 2800 RPM	

The horsepower ratings listed are established in accordance with the Society of Automotive Engineers Test Code J607. For practical operation, the horsepower loading should not exceed 85% of these ratings. Engine power will decrease 3% for each 1,000 feet above sea level and 1% for each 10° above 60° F.

Major engine repairs should not be attempted unless you have the proper tools and a thorough knowledge of internal combustion engines.

TUNE-UP SPECIFICATIONS

	A.C.	Autolite	Champion
Spark Plug Type			
Short Plug	CS-45	A7N	CJ-8
Long Plug	GC-46	A71	J-8
Spark Plug Gap			.030"
Ignition Point Gap			.021"
Intake Valve Clearance			.007" - .019"
Exhaust Valve Clearance			.017" - .019"

STORAGE INSTRUCTIONS

Engines stored for over 30 days should be completely drained of fuel to prevent gum deposits forming on essential carburetor parts, fuel filter, fuel lines and tank.

- Remove filter bowl, open shut off valve and drain tank completely.
- Replace filter bowl. Leave fuel valve open.
- Operate engine until it stops from lack of fuel.
- While engine is still warm, drain and clean the oil sump. Refill with fresh oil.
- Remove spark plug, pour one ounce of SAE 30 oil into cylinder and crank slowly to spread oil. Replace spark plug.
- Clean dirt and chaff from cylinder, cylinder head fins and blower housing.

ENGINE, DRIVE SHAFT AND COUPLING REMOVAL

B-1 Tractor

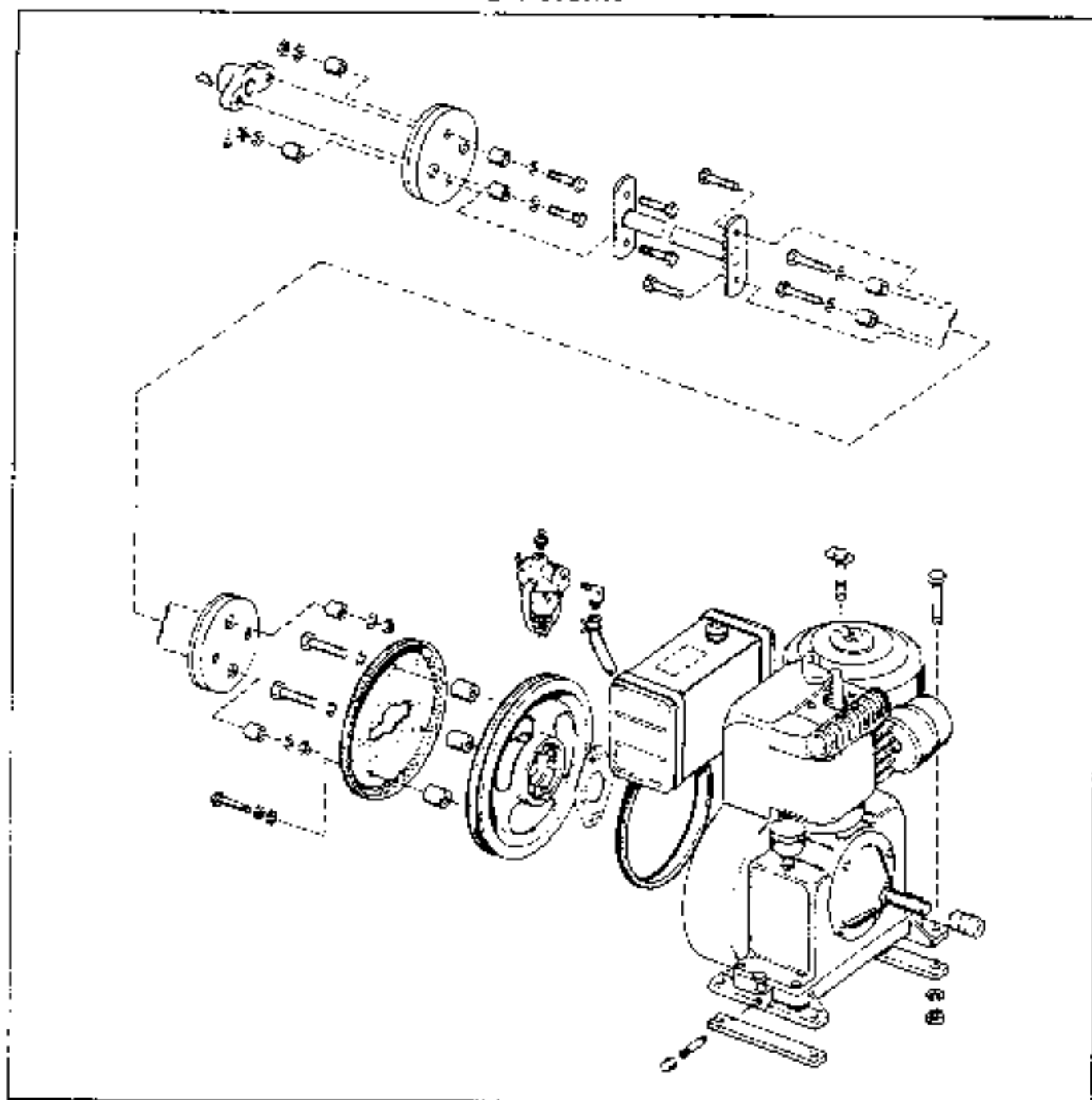

1. Remove hood.
2. Remove grille and grille support.
3. If equipped with electric starter, remove battery ground clamp.
4. Disconnect wire running from starter switch to starter.
5. Disconnect fuel line from tank.
6. Remove ignition wire from switch.
7. Disconnect choke and throttle cables from tractor when engine is being removed.

8. Disconnect front drive shaft coupling from engine.
9. Disconnect complete drive shaft when repairs are needed on the shaft or couplings.
10. Remove capscrews holding engine to frame.
11. Remove oil drain pipe.
12. Remove engine.

Installation is the reverse of engine removal.

ENGINE, DRIVE SHAFT AND COUPLING REMOVAL

B-10 (9 H. P.), B-10 (10 H. P.), Big Ten, B-12 Tractors Prior to S/N 50001 Tractors

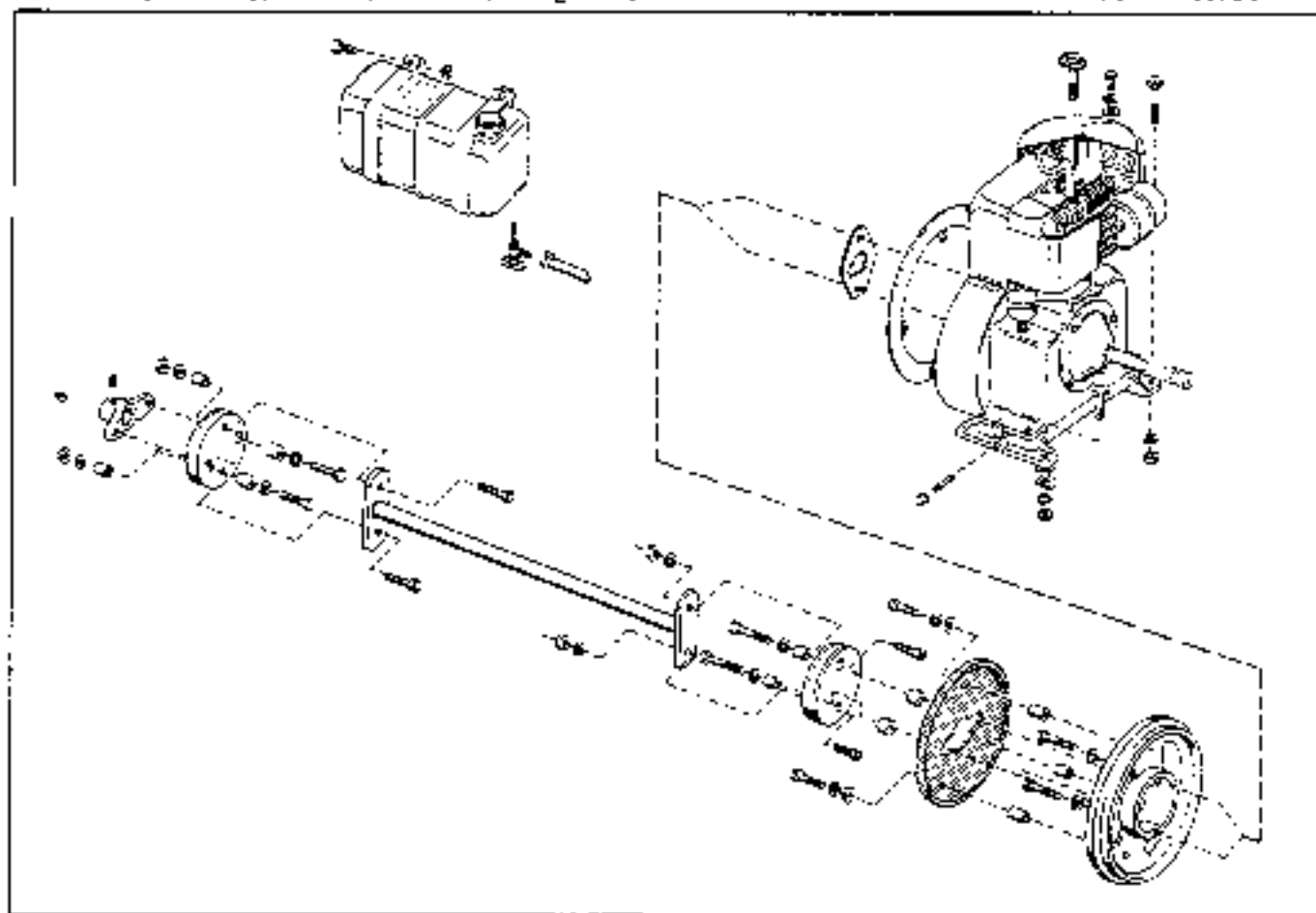

1. Remove hood, grille and grille support.
2. Disconnect battery ground clamp.
3. Disconnect ignition wire.
4. Remove fuel line.
5. Remove starter generator wires.
6. Remove choke and throttle cables when engine is being removed.
7. Remove oil drain pipe.
8. Disconnect front coupling of drive shaft from engine.
9. Disconnect complete drive shaft when repairs are needed on the shaft or couplings.
10. Remove capscrews holding engine to frame.
11. Slide engine forward to remove.

Installation is the reverse of removal.

ENGINE, DRIVE SHAFT AND COUPLING REMOVAL
B-12, B 110, B 112, HB-112, B-210, B-212, HB-212

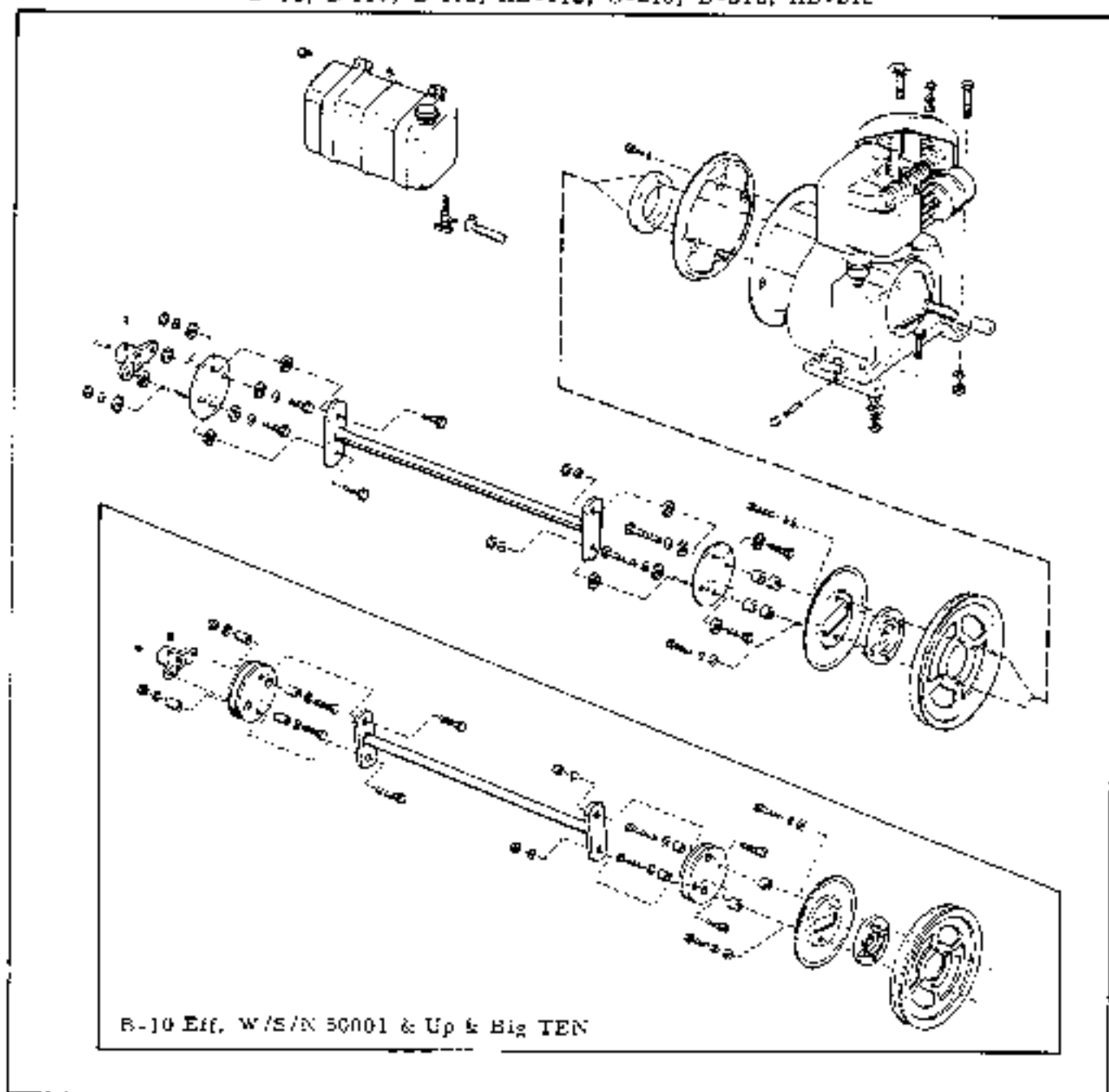

1. Remove hood, side panels.
2. Remove battery, fuel tank.
3. Remove dash assembly.
4. Remove shift lever ball and brake lock.
5. Remove frame cover assembly.
6. Remove choke and throttle cables, when engine is being removed.
7. Disconnect front coupling of drive shaft from engine.
8. Disconnect complete drive shaft when repairs are needed on the shaft or couplings.
9. Remove oil drain plug.
10. Remove capscrews holding engine to frame.
11. Remove engine.

Installation is the reverse of removal.

NOTE: On units equipped with hydraulic system, removal of quadrant and lever assembly will simplify removal of drive shaft from engine.

STORING YOUR TRACTOR

When your tractor is not to be used for some time, it should be stored in a dry protected place. Leaving your tractor outdoors, exposed to the elements, will result in materially shortening its life.

PREPARING TRACTOR FOR STORAGE

1. Clean and completely lubricate the tractor.
2. Block tractor up to remove weight from tires and to keep tires from contact with moist floor. Protect tires from light.
3. Remove spark plug and pour one tablespoon of light motor oil on top of piston. Crank engine over a few times and replace spark plug.
4. To avoid gum content collections, drain the fuel tank and carburetor and clean out the fuel strainer and sediment bowl.
5. Clean the exterior of the engine.
6. Remove battery and store in a cool dry place above freezing. Keep battery fully charged.

7. When tractor is removed from storage, it should be serviced thoroughly, including draining and refilling the crankcase with fresh oil.

STARTING ENGINE AFTER STORAGE

1. Remove spark plug and wipe dry, crank engine rapidly until excess oil has been blown out of spark plug hole. Replace spark plug.
2. Fill the fuel tank.
3. Install a fully charged battery and be sure the proper connections are made.
4. Service air cleaner.
5. Drain crankcase and refill with fresh clean oil.
6. Start engine and let it run slowly for the first few minutes. Move tractor outside of storage room, or keep all doors open. Do not operate engine at high speeds immediately after first starting.
7. Inflate tires to the correct operating pressure before operating tractor.

DIAGNOSING ENGINE DIFFICULTY

ENGINE HARD STARTING

1. Loose or grounded high tension, or breaker point leads.
2. Improper breaker point gap.
3. Faulty spark plug.
4. Faulty condenser or coil.
5. Incorrect spark timing.
6. Gasoline not getting to carburetor.
7. Dirt or gum in carburetor or fuel line.
8. Carburetor improperly adjusted.
9. Valves leaking or sticking.
10. Piston rings worn excessively.
11. Cylinder head gasket leaking.

ENGINE OVERHEATING

1. Insufficient available cool air.
2. Dirty air intake screen, shroud or cooling fins.
3. Improper fuel.
4. Fuel mixture too lean.
5. Improper ignition timing.

ENGINE BACKFIRING

1. Fuel mixture too lean.
2. Sticky intake valve.
3. Improper ignition timing.

ENGINE MISSING AT HIGH SPEED

1. Spark plug gap too wide.
2. Improper carburetor adjustment, or lack of fuel.
3. Wrong type spark plug, use spark plug that is recommended.
4. Improper timing.

ENGINE MISSING UNDER SLOW HARD PULL

1. Spark plug gap too wide.
2. Pitted breaker points.
3. Partially fouled spark plug.
4. Defective ignition cable.

ENGINE KNOCKING

1. Fuel octane rating too low.
2. Engine overheated.
3. Improper timing.
4. Loose connecting rod.
5. Excessive carbon in combustion chamber.

ENGINE OPERATING ERRATICALLY

1. Clogged fuel line.
2. Water in fuel.
3. Faulty choke control.
4. Improper fuel.
5. Loose ignition system connections.
6. Air leaks in manifold or carburetor connections.

ENGINE WILL NOT IDLE

1. Improper carburetor idling adjustment.
2. Carburetor jets clogged.
3. Spark plug gap too narrow.
4. Leaking carburetor or manifold gaskets.
5. Sticking or leaking valves.
6. Weak coil or condenser.

INDEX

TRACTOR

STEERING GEAR REMOVAL

B-1	C-1
B-10 Prior to S. N. 50001	C-1
Big TEN, B-10 S. N. 50001 & Up	C-1
B-12, B-110, B-112, HB-112	C-1
B-210, B-212, HB-212	C-1
B-207, B-208	C-2

FRONT AXLE ASSEMBLY

All Models Except B-207, B-208	C-3
B-207, B-208	C-4

LUBRICATION	C-5
-------------------	-----

ADJUSTMENTS	C-12
-------------------	------

CONTROLLED TRACTION DIFFERENTIAL

ADJUSTMENT	C-15
------------------	------

REAR LIFT DRAWBAR	C-16
-------------------------	------

CLUTCH & BRAKE

B-10 Prior to S. N. 50001	C-17
B-1	C-18
Big TEN, B-12, B-10 S. N. 50001 & Up, B-110	C-19
B-112 Prior to S. N. 20001	C-19
B-112 S. N. 20001 & Up	C-20
HB-112, HB-212	C-20
B-207, B-208	C-21

C 

THIS PAGE INTENTIONALLY BLANK

STEERING GEAR REMOVAL

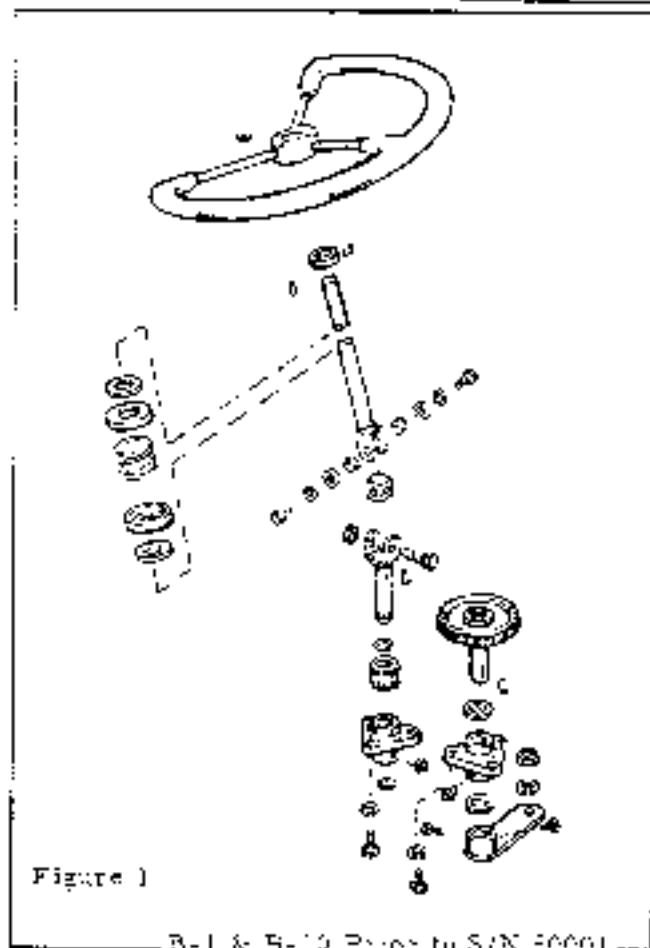

Figure 1

B-1 & B-10 Prior to S/N 50001-

B-1 Tractor Figure 1

1. Tilt seat assembly rearward, remove hood.
2. Loosen setscrew, remove steering wheel.
3. Remove keys and washers from top of steering shaft.
4. Remove battery.
5. Disconnect fuel line at tank.
6. Remove capscrews holding frame cover to frame.
7. Remove gear shift lever ball.
8. Remove capscrew from gear shift rod guide.
9. Lift off frame cover and tank assembly.
10. Disconnect rear tie rod ball joint.
11. Loosen setscrew and remove steering arm, woodruff key and washer from steering gear.
12. Remove steering driven gear.
13. Removal of shaft and pinion gear - remove snap ring and washer from lower end of shaft.
14. Lift shaft out of bearing.
15. Remove capscrews to remove bearing.

Installation is the reverse of removal.

B-10 Tractor Figure 1

1. Remove hood, side panels and battery.
2. Loosen setscrew and remove steering wheel and key.

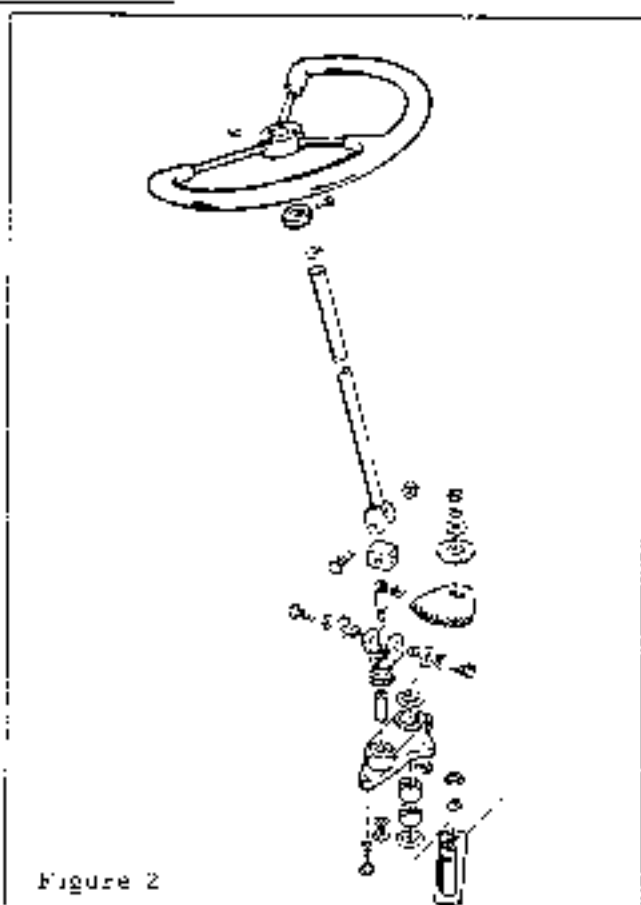

Figure 2

B-10 S/N 50001 & Up, B-12, B-110, B-112, HB, 112, B-210, B-212, H3-212

3. Lift off dash.
4. Remove tank support.
5. Disconnect rear tie rod ball joint.
6. Loosen setscrews, remove steering arm.
7. Remove steering driven gear.
8. Remove snap ring and washer from lower end of shaft.
9. Lift out shaft assembly.
10. Remove capscrews from main frame to remove bearings.

Reassembly is the reverse of removal.

Figure 2

1. Remove hood and side panels.
2. Remove steering wheel and key.
3. Remove battery and fuel tank.
4. Remove dash assembly.
5. Remove locking collar on steering shaft.
6. Disconnect universal joint in steering shaft, remove shaft.
7. Disconnect tie rod.
8. Remove steering gear.
9. Remove steering bracket.

Installation is the reverse of removal.

STEERING GEAR REMOVAL

B-207 and B-208

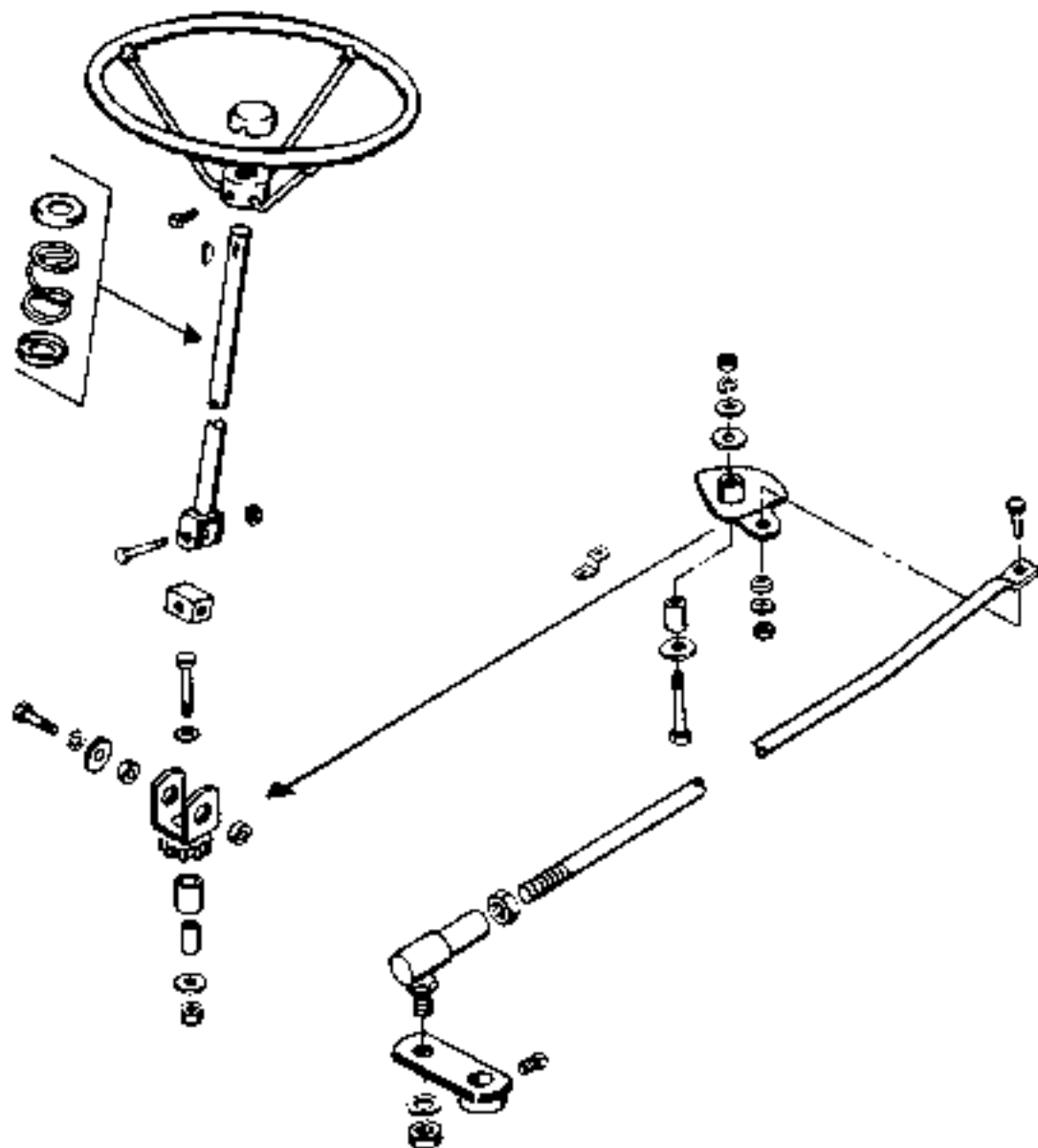

1. Remove hood and steering wheel.
2. Disconnect ignition wire and choke and throttle cables.
3. Unbolt and lift off dash assembly and upper steering shaft support.
4. Raise front of tractor and disconnect drag link from steering gear.
5. Unbolt and remove steering gear.
6. Remove nut securing steering pinion to frame and remove upper steering shaft, "U" joint and steering pinion.
7. When reassembling the steering units, move steering gear closer to steering pinion to remove excessive steering wheel play.
8. To reasonable, reverse disassembly procedure.

FRONT AXLE ASSEMBLY
All Models

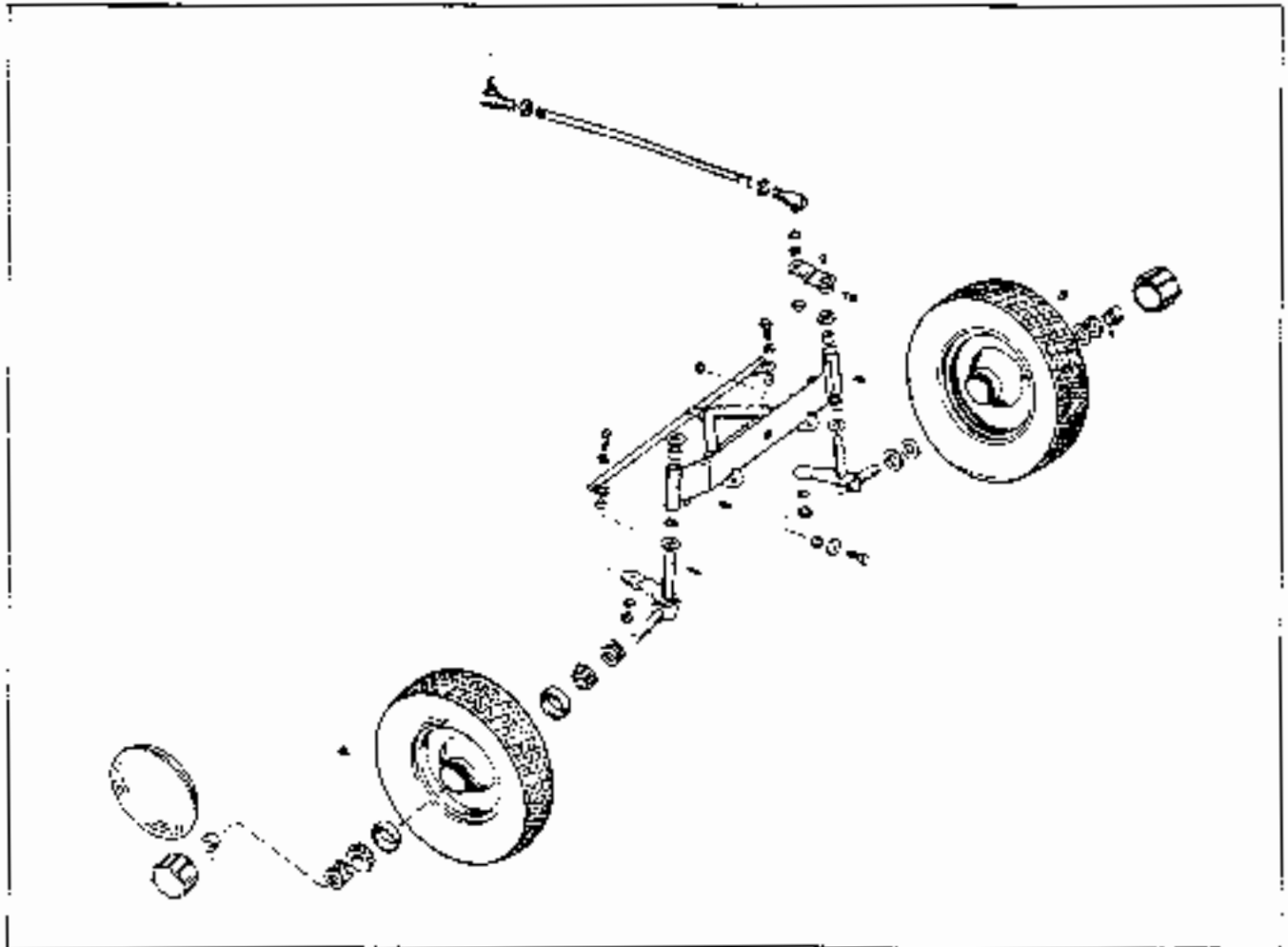

AXLE MAIN FRAME

1. Raise tractor front end.
2. Disconnect tie rod ball joint.
3. Remove capscrew and spacer from center of axle.
4. Lower front of axle and pull forward to slide stabilizer out of frame angle. The frame angle is replaceable if it is excessively worn.

DRAG LINK

1. Remove bolts, washers and spacers that hold

tie rod to spindles.

STEERING SPINDLES

1. Raise tractor front end, remove wheels.
2. Remove drag link.
3. Remove steering arm and key from left spindle and remove spindle.
4. Remove cotter key from right spindle and remove spindle.
5. There are 4 spindle bearings. Two in each end of axle frame.

FRONT AXLE ASSEMBLY

B-207 and E-208

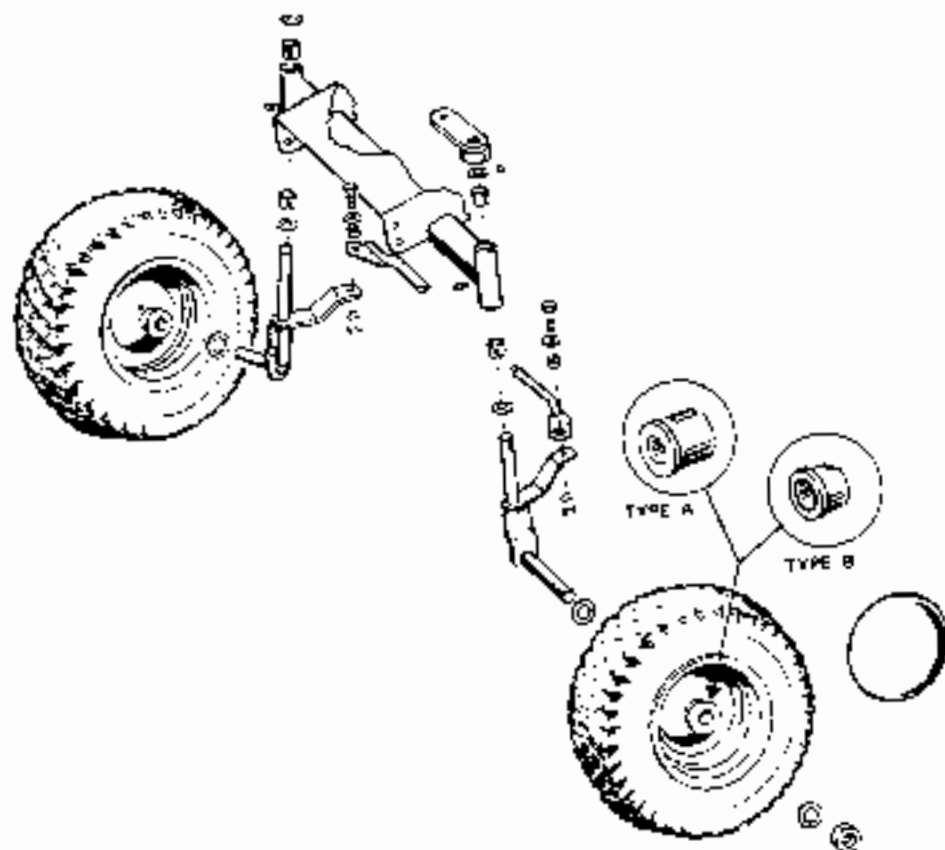

1. Front axle main member on the B-207 and the E-208 is welded to the frame. New frame assembly is necessary if axle cannot be repaired.
2. Refer to the figure above for disassembly and assembly of components.
3. Inspect the bushings on the spindle assemblies and the bearings in the front wheels.
4. Replace where needed.
5. Clean dirt and grease off of all parts.
6. Lubricate both of the spindle end and assembly unit.

LUBRICATION
B-1 Tractor

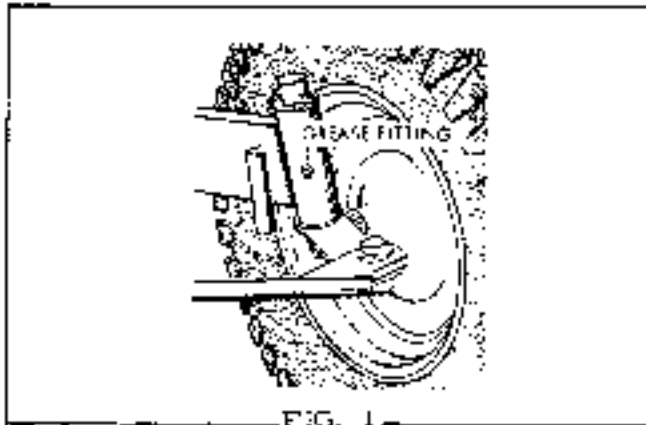

FIG. 1

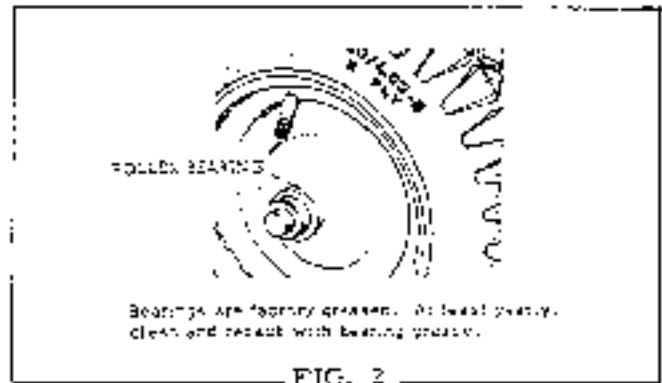

FIG. 2

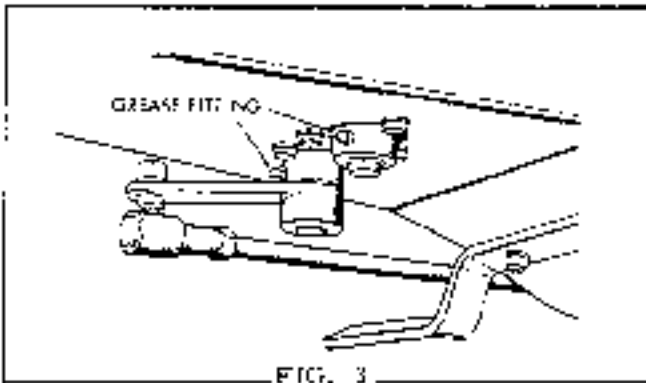

FIG. 3

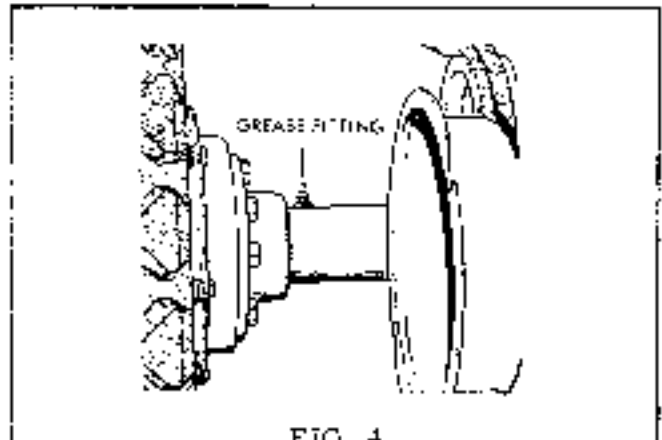

FIG. 4

The tractor has a total of 5 grease fittings which require lubrication with general purpose automotive grease. Use a standard grease gun for the following fittings:

- (2) Front Spindles - Fig. 1
- (2) Steering Mechanism - Fig. 3
- (1) Rear Axle Tube - Fig. 4

Before lubricating, wipe each grease fitting with a rag to prevent grit and dirt from being carried into bearings with new grease.

The Starter-Generator was equipped with two oil cups requiring lubrication with SAE 20 motor oil. Apply 8 to 10 drops of oil every 100 hours operating time. **DO NOT OVER OIL.** See Fig. 5. On later units, bearings require no lubrication as they are prelubricated for life.

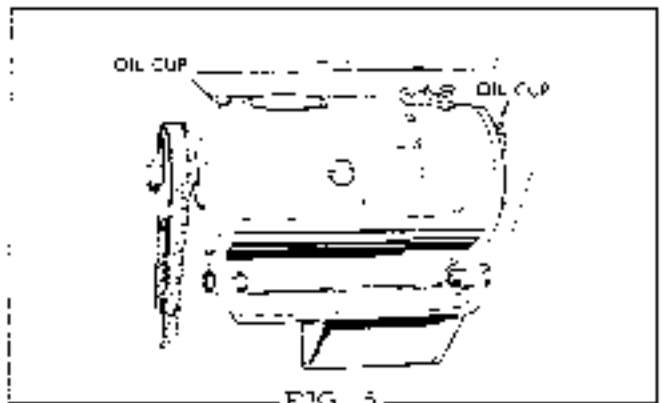

FIG. 5

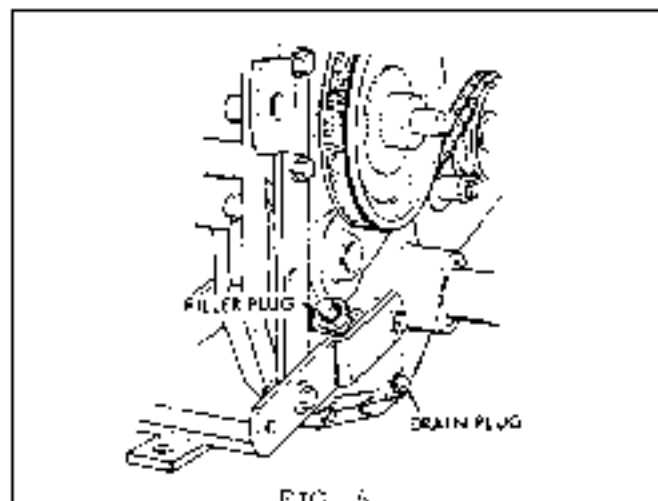

FIG. 6

The transmission has a capacity of 1-1/2 qts. of SAE 90 oil and is filled at the factory. It will not normally require replenishment, but occasionally check drain plug for tightness and axle tube oil seals for leakage. Keep oil up to level of filler plug. Remove vent plug from top of transmission and allow oil to settle to normal level before checking. (See Fig. 6).

The bevel gear housing has a capacity of 1 pint of SAE 90 oil and is filled at the factory. It will not normally require replenishment, but occasionally check drain plug for tightness and oil seals for leakage. Keep oil up to level of filler plug. (See Fig. 7).

ENGINE

Engine - Service air cleaner and crankcase as recommended in engine service manual. Be sure oil in air cleaner is maintained in clean condition. Never use oil in crankcase for more than 25 hours of operation. (See Fig. 8).
CLEAN AIR AND CLEAN ENGINE OIL WILL GIVE LONG TROUBLE-FREE OPERATION. DIRT WILL RUIN YOUR ENGINE IN A SHORT TIME. A funnel and extension are included with the tractor for use in changing oil.

TIRES

The tires of the tractor are inflated with air pressure in excess of the normal amount for shipment. For comfort of operation, release some of the pressure until a pressure of 12 lbs. per square inch is attained for front tires and 14 lbs. per square inch is attained for rear tires. Maintain tires at these pressures.

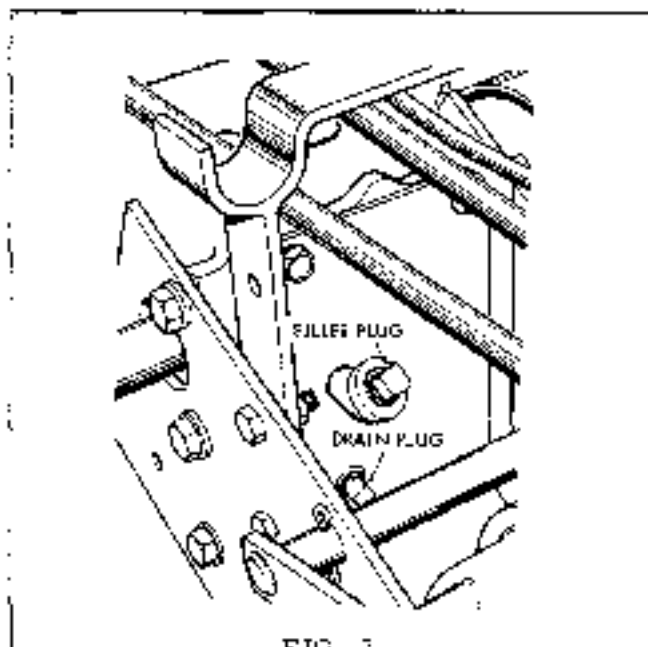

FIG. 7

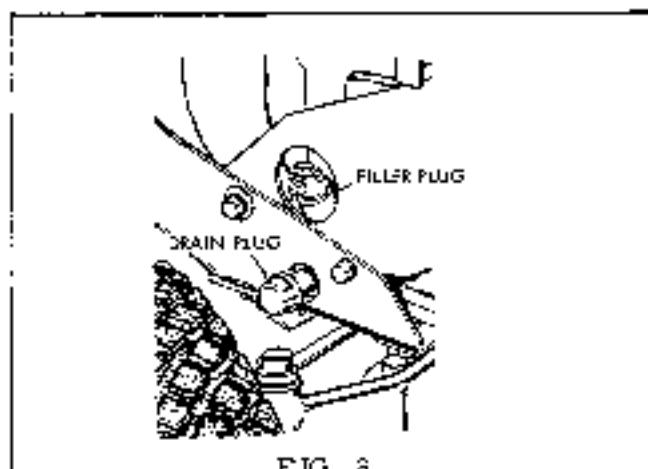

FIG. 8

BATTERY

The battery should be kept clean and dry at all times. Keep battery snugly fastened in place and check battery cables for tight connections. Vent caps should be kept tight and vent holes in vent caps must be kept open at all times to permit gases formed in battery to escape. Do not over-fill. Keep filled so solution is 1/16" above separators. When installing battery, install shield to prevent battery terminals from contacting hood. Full maintenance instructions are provided on separate instruction card for battery.

If tractor is not used for an extended period during winter, remove battery and store in a fully charged condition in a cool place.

LUBRICATING
B-15 (9 H.P.) Tractor

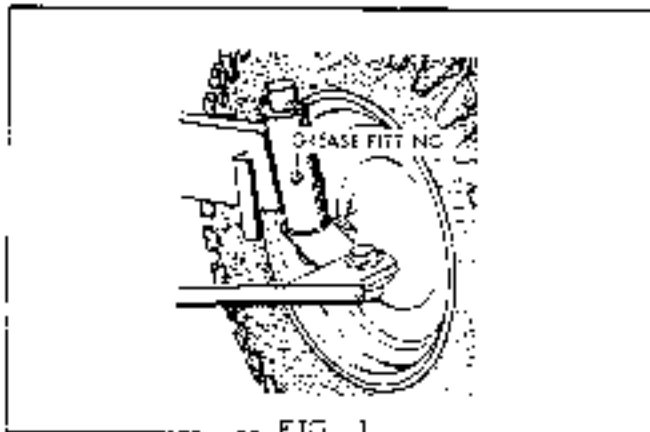

FIG. 1

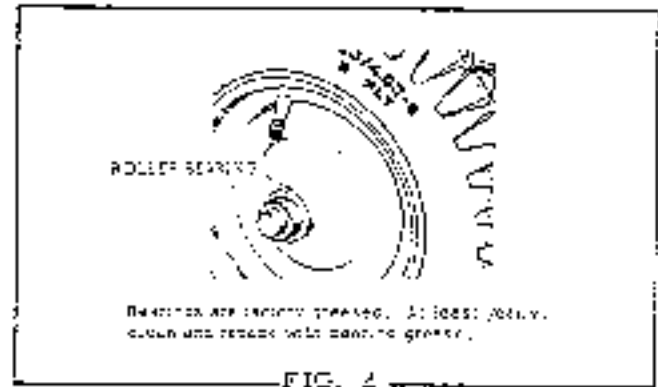

FIG. 2

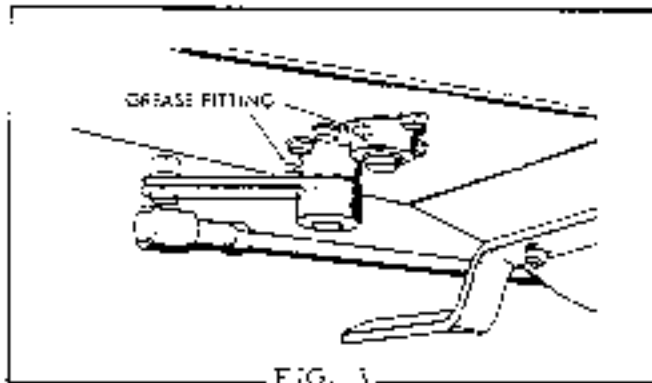

FIG. 3

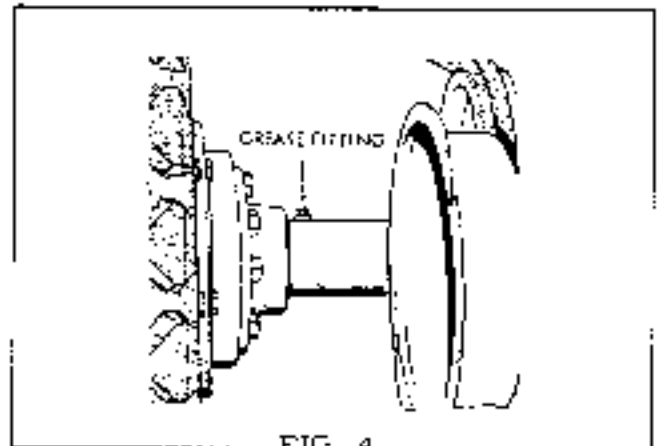

FIG. 4

The tractor has a total of 5 grease fittings which require lubrication with general purpose automotive grease. Use a standard grease gun for the following fittings:

- (2) Front Spindles - Fig. 1
- (2) Steering Mechanism - Fig. 3
- (1) Rear Axle Tube - Fig. 4

Before lubricating, wipe each grease fitting with a rag to prevent grit and dirt from being carried into bearings with new grease.

The transmission has a capacity of 1-1/2 qts. of SAE 90 oil and is filled at the factory. It will not normally require replenishment, but occasionally check drain plug for tightness and axle tube oil seals for leakage. Keep oil up to level of filler plug. Remove vent plug from top of transmission and allow oil to settle to normal level before checking. (See Fig. 5).

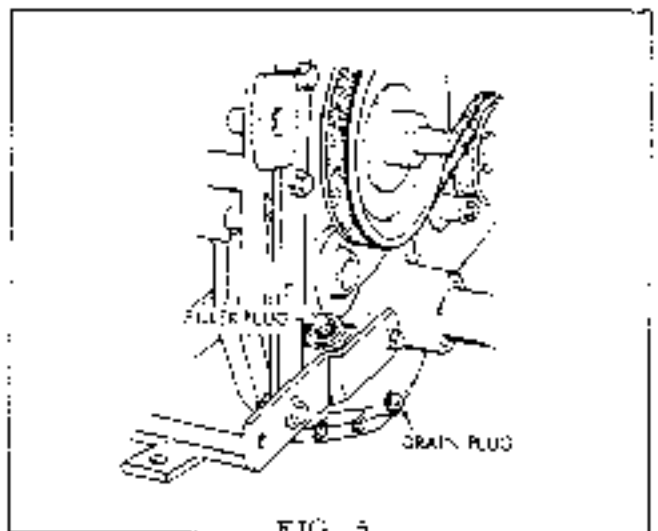

FIG. 5

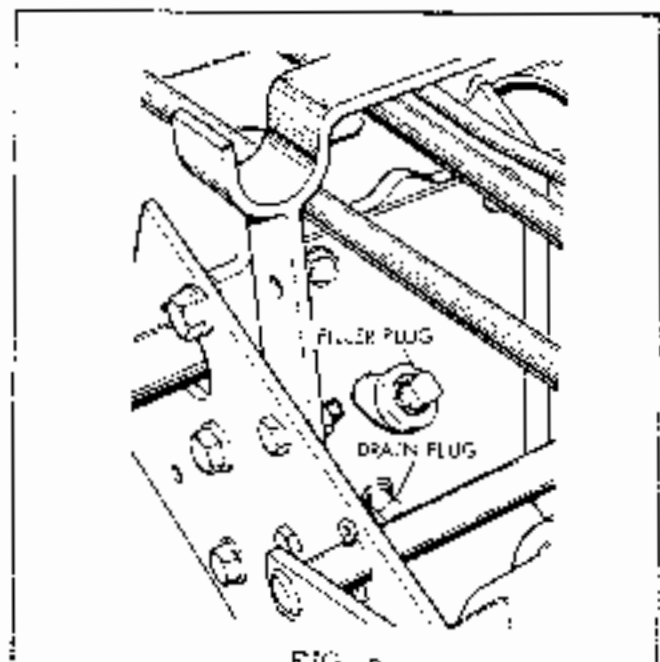

FIG. 6

The level gear housing has a capacity of 1 pint of SAE 90 oil and is filled at the factory. It will not normally require replenishment, but occasionally check drain plug for tightness and oil seals for leakage. Keep oil up to level of filler plug. (See Fig. 6).

ENGINE

Service air cleaner and crankcase as recommended in engine service manual. Never use oil in crankcase for more than 25 hours of operation. (See Fig. 7). **CLEAN AIR AND CLEAN ENGINE OIL WILL GIVE LONG TROUBLE-FREE OPERATION. DIRTY WILL RUIN YOUR ENGINE IN A SHORT TIME.** A funnel and extension are included with the tractor for use in changing oil.

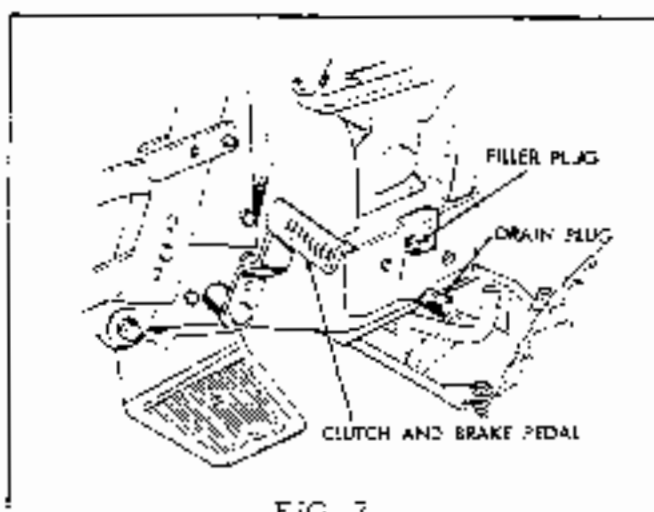

FIG. 7

TIRES

The tires of the tractor are inflated with air pressure in excess of the normal amount for shipment. For comfort of operation, release some of the pressure until a pressure of 12 lbs. per square inch is attained for front tires and 8 lbs. per square inch is attained for rear tires. Maintain tires at these pressures.

BATTERY

The battery should be kept clean and dry at all times. Keep battery snugly fastened in place and check battery cables for tight connections. Vent caps should be kept tight and vent holes in vent caps must be kept open at all times to permit gases formed in battery to escape. Do not overfill. Keep filled so solution is 1/16" above separators. When installing battery, install shield to prevent battery terminals from contacting hood. Full maintenance instructions are provided on separate instruction card for battery.

If tractor is not used for an extended period during winter, remove battery and store in a fully charged condition in a cool place.

MAINTENANCE

Big Ten, B-10 (10 H.P.), B-12 Tractors

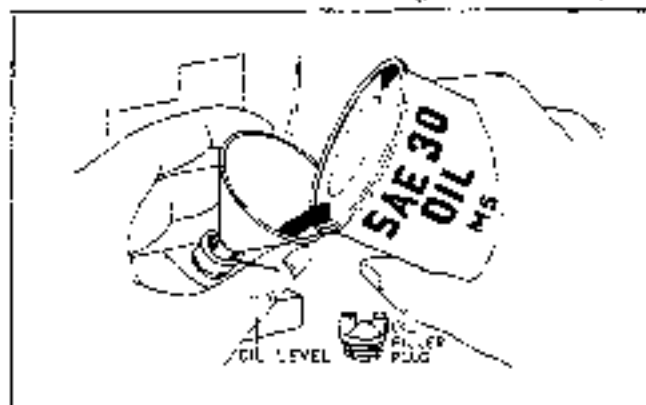

Check daily or every 5 hours of operation.

OIL RECOMMENDATIONS

WINTER

(Below 40°F.)
Use SAE 5W-20
If not available
Use SAE 10W
Above 10°F.

SUMMER

(Above 40°F.)
Use SAE 30
If not available
Use SAE 10W-30

Any high quality detergent oil having the American Petroleum Institute classification "For Service MS" can be used in your Briggs and Stratton engine. Detergent oils keep the engine cleaner and retard the formation of gum and varnish deposits.

Nothing should be added to the recommended oils.

CRANKCASE OIL

Remove the oil filler plug. Place the engine level. Fill the crankcase to overflowing. **POUR SLOWLY. CAPACITY 4 PINTS. REPLACE THE FILLER PLUG.**

CHANGE OIL (Crankcase)

Change oil after 5 hours of operation. Remove the oil drain plug. Drain oil while engine is warm. Replace drain plug. Remove oil filler cap or plug and refill with new oil. Replace oil filler cap or plug. Add oil regularly after each 5 hours of operation. Thereafter change oil every 25 hours of operation.

SERVICING "OIL-FOAM" AIR CLEANER

Clean and re-oil the air cleaner frequently (every few hours under extremely dusty conditions). Clean and re-oil at least every 25 hours under normal conditions.

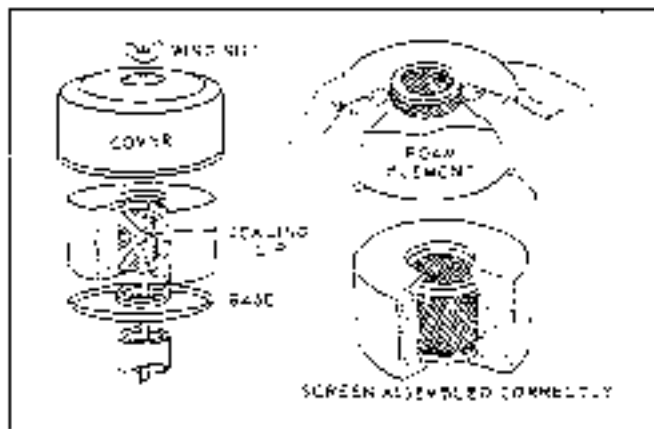
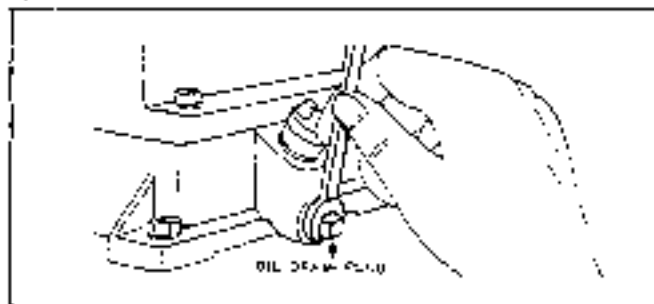

1. Remove wing nut and cover.
2. Lift off foam element from base.
3. Push down foam element as shown and pull out screen.
4. A - Wash foam element in kerosene or solvent.
B - Squeeze dry and blot to remove all solvent. Re-oil with 6 tablespoons engine oil.
C - Squeeze again to spread oil through foam element.
D - Put screen inside element. Be sure sealing lip is over end of screen (top and bottom).
5. Reassemble parts as shown. Fasten to engine. Screw wing nut down tight.

CLEAN COOLING SYSTEM

Grass or chaff may clog cooling system after prolonged service in cutting dry grasses or hay. Continued operation with a clogged cooling system causes severe overheating and possible engine damage. Remove blower housing and clean regularly.

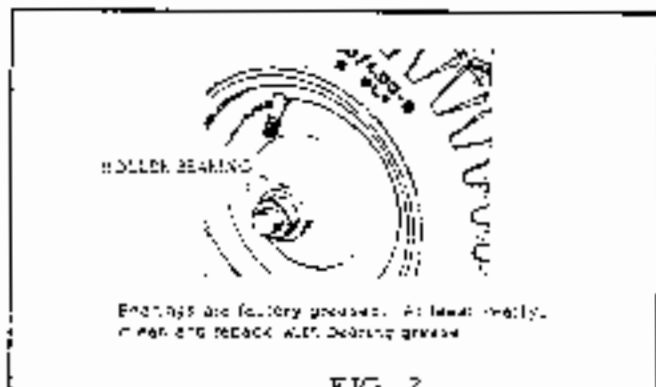
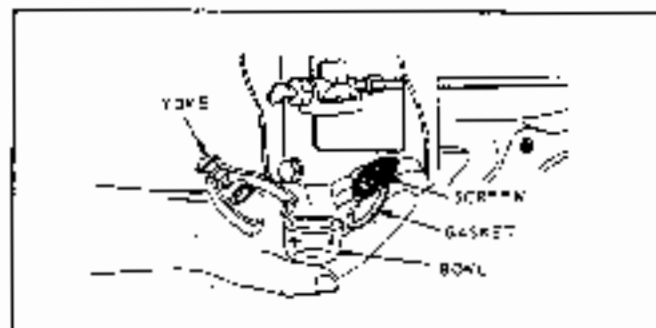

FIG. 2

DRAINING FUEL TANK AND CLEANING FUEL FILTER

Loosen thumb screw below filter bowl.

Remove and clean filter bowl and screen.

Open shut-off valve to see if fuel flows freely from the tank.

IMPORTANT: If you find a gummy, varnish-like substance use alcohol or acetone to dissolve it.

NOTE: See Engine Service Manual for complete engine service.

Lubricate grease fittings every 25 hours of operation.

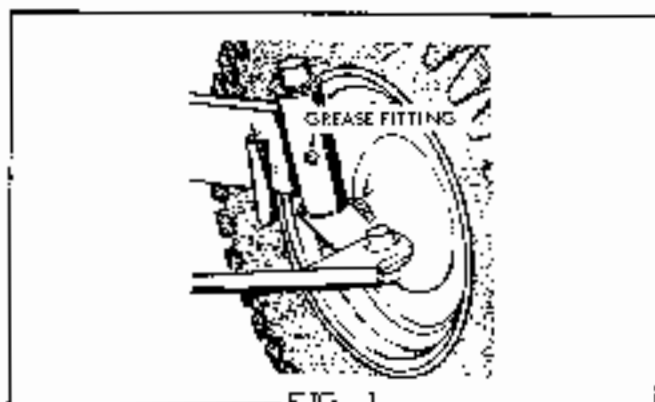

FIG. 1

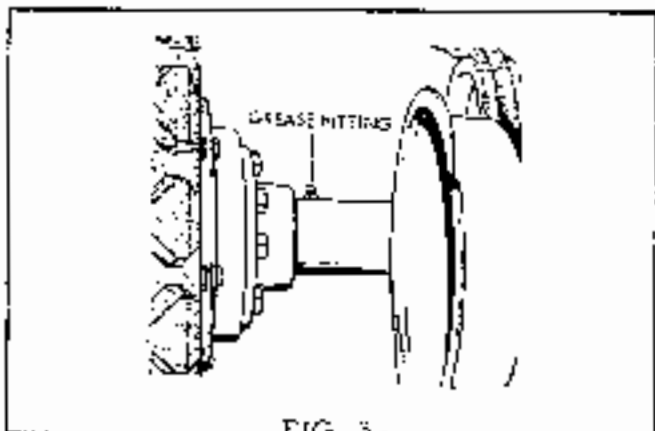

FIG. 3

The tractor has a total of 3 grease fittings which require lubrication with general purpose automotive grease. Use a standard grease gun for the following fittings:

Before lubricating, wipe each grease fitting with a rag to prevent grit and dirt from being carried into bearings with new grease.

- (2) Front Spindles - (Fig. 1)
- (1) Rear Axle Tube - (Fig. 3)

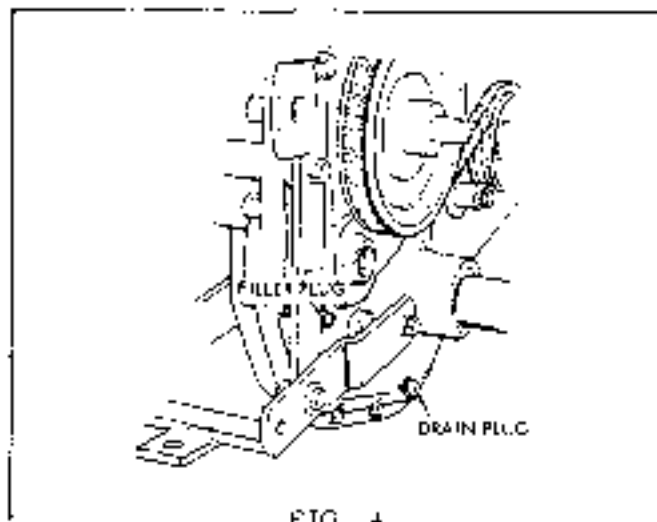

FIG. 4

CHECK PERIODICALLY

TRANSMISSION

The transmission has a capacity of 1-1/2 qts. of SAE 90 oil and is filled at the factory. It will not normally require replenishment, but occasionally check drain plug for tightness and axle tube oil seals for leakage. Maintain oil level at lower edge of filler plug hole. Remove vent plug from top of transmission and allow oil to settle to normal level before checking. (See Fig. 4).

BEVEL GEAR HOUSING

The bevel gear housing has a capacity of 1 quart of SAE 90 oil and is filled at the factory. It will not normally require replenishment, but occasionally check drain plug for tightness and oil seals for leakage. Keep oil up to level of filler plug. (See Fig. 5).

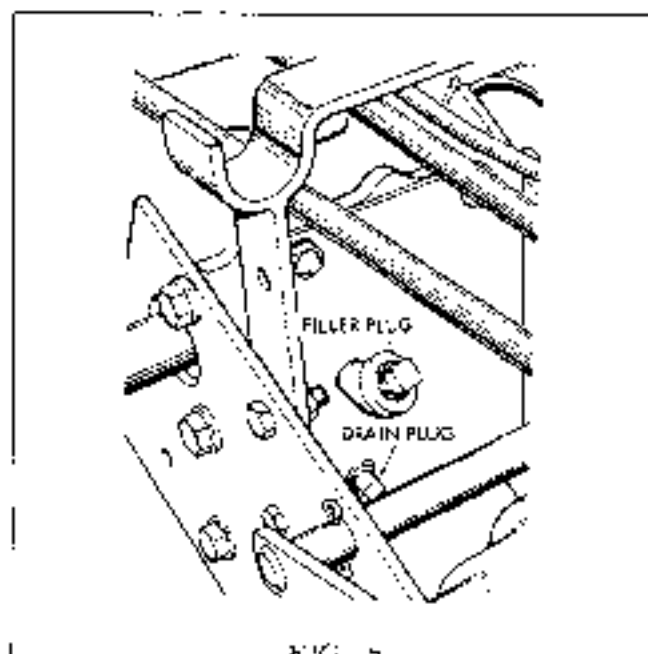

FIG. 5

TIRES

Periodically check tire pressure. Maintain pressure to specified pressure as given.

	Tractor	With Loader	With Fork Lift
Front	6 PSI	20 PSI	20 PSI
Rear	12 PSI	14 PSI	20 PSI

BATTERY

The battery should be kept clean and dry at all times. Keep battery snugly fastened in place and check battery cables for tight connections. Vent caps should be kept tight and vent holes in vent caps must be kept open at all times to permit gases formed in battery to escape. Full maintenance instructions are provided on separate instruction card for battery.

If tractor is not used for an extended period during winter, remove battery and store in a fully charged condition, in a cool place.

ADJUSTMENTS

B-1 Tractor

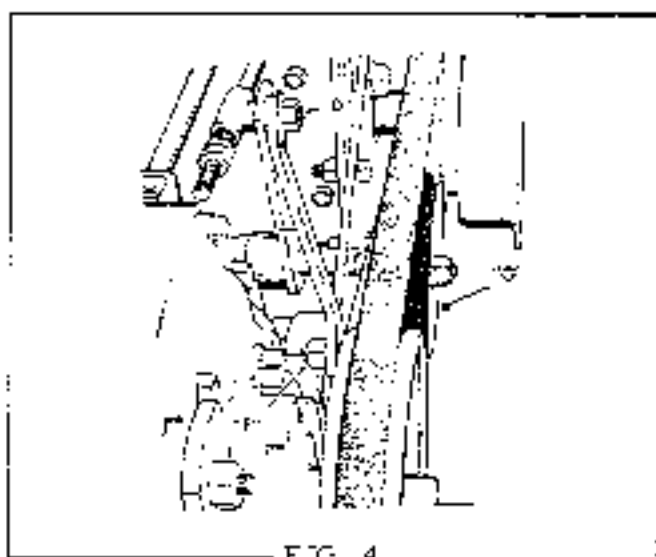
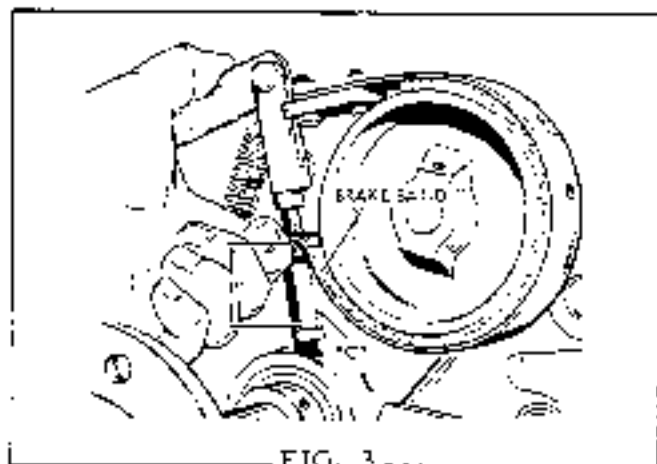
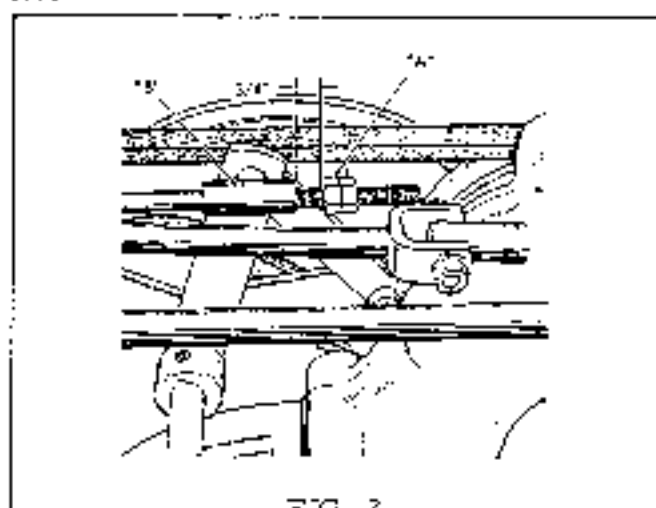
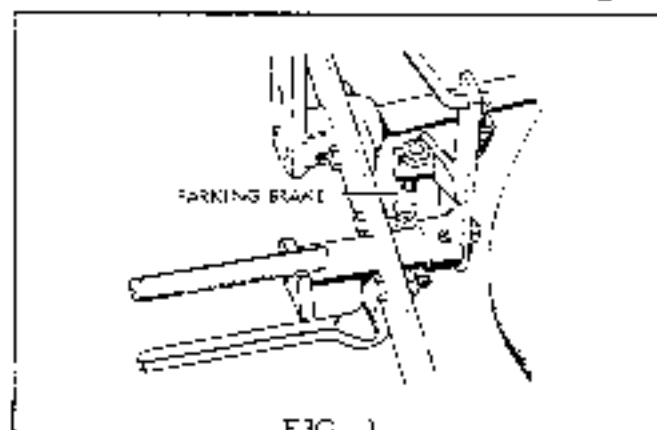

PARKING BRAKE

Depress foot pedal until brake holds securely; flip capscrew toward rear for park. (See Fig. 1). Adjust length of screw to permit screw head to wedge on bottom of frame and hold lever in depressed position with brake applied.

CLUTCH AND BRAKE

1. With clutch and brake pedal in normal position (i. e., clutch engaged and brake released), adjust hex nuts (A) to give $3/4$ " clearance between rod guide assembly (B) and nuts. (See Fig. 2).
2. Pull brake band up by hand so that it is tight around brake drum. Adjust hex screw (C) to have a clearance of 1" between brake band and screw as shown in Fig. 3.
3. Adjust nut (D) to permit clutch link (E) to pivot freely without excessive play. (See Fig. 4).

4. Adjust nut (F) to permit clutch link (E) to pivot freely without excessive play and check to see that nut has at least $1-1/2$ " of travel before touching transmission case. (See Fig. 4).
5. When clutch is disengaged and brake is applied, the clutch and brake lever assembly should have at least 1" of travel before touching bevel gear housing.
6. To compensate for belt stretch or other variances it may be necessary to move idler pulley (G) Fig. 4 into the alternate hole provided in its lever arm.

ADJUSTMENTS
B-10 (9 H. P.) Tractor

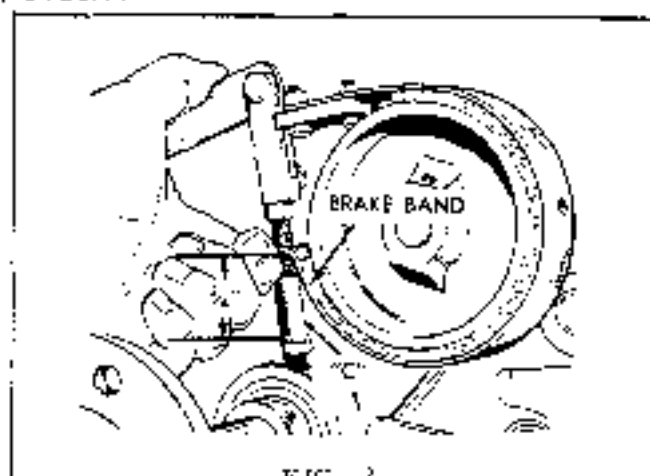
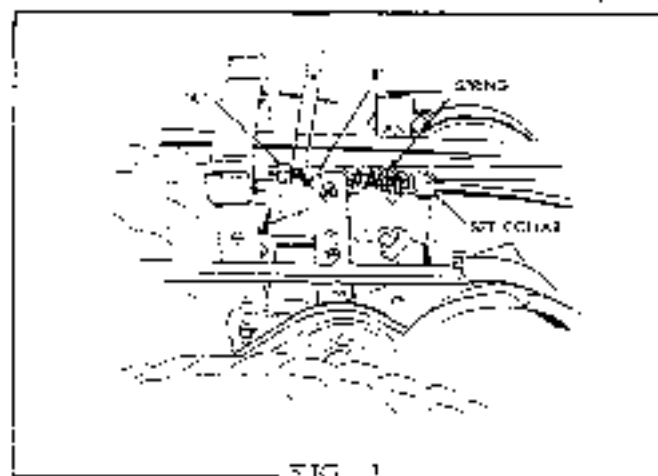

CLUTCH

With clutch and brake pedal in normal position (i. e., clutch engaged and brake released), adjust hex nuts (A) to give $3/4$ " clearance between rod guide assembly (B) and nuts. (See Fig. 1).

Position the set collar on the clutch rod to compress the spring about $5/8$ ". Then recheck and position the locknuts "A" to leave a spacing of about $3/4$ " between them and the end of the rod guide "B", Fig. 1. Check to see that when the pedal is operated, the spring is completely decompressed as the locknuts engage the end of the rod guide.

BRAKE ADJUSTMENT

Pull the brake band up by hand so that it is tight around the brake drum. Adjust the hex screw (C) Fig. 2 to give a clearance of about $3/4$ " between the brake band and the screw head. Then check to see that the idler pulley releases the belt properly before the brake is applied. If the brake does not hold properly when the pedal is pushed all the way forward, reduce slightly the spacing between the head of the hex bolt and the brake band. Then recheck the clutch rod adjustment for proper idler release.

ADJUSTMENTS
Big Ten, B-10 (10 H.P.), B-13 Tractors

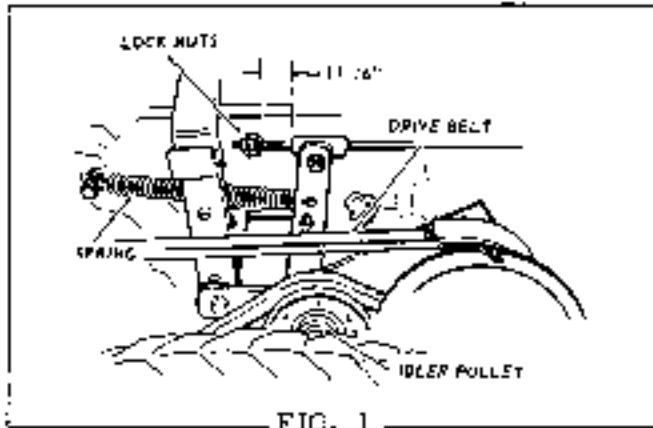

FIG. 1

Seasonal adjustments should be made on the Big Ten tractor.

CLUTCH ADJUSTMENT

Adjust locknuts on clutch rod to give 11/16" space between them and idler pulley pivot arm. (See Fig. 1).

BRAKE ADJUSTMENT

Pull the brake band up by hand so that it is tight

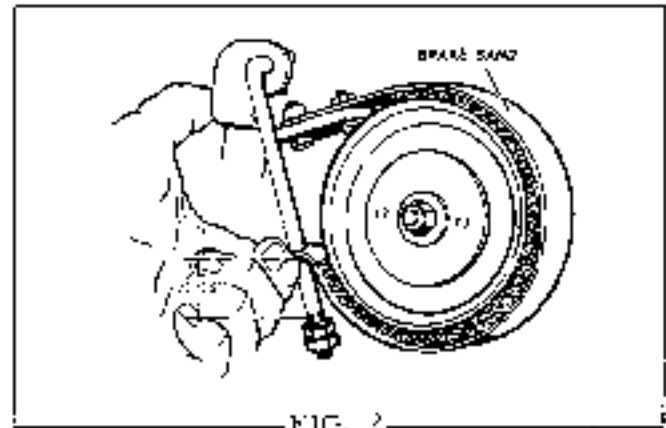
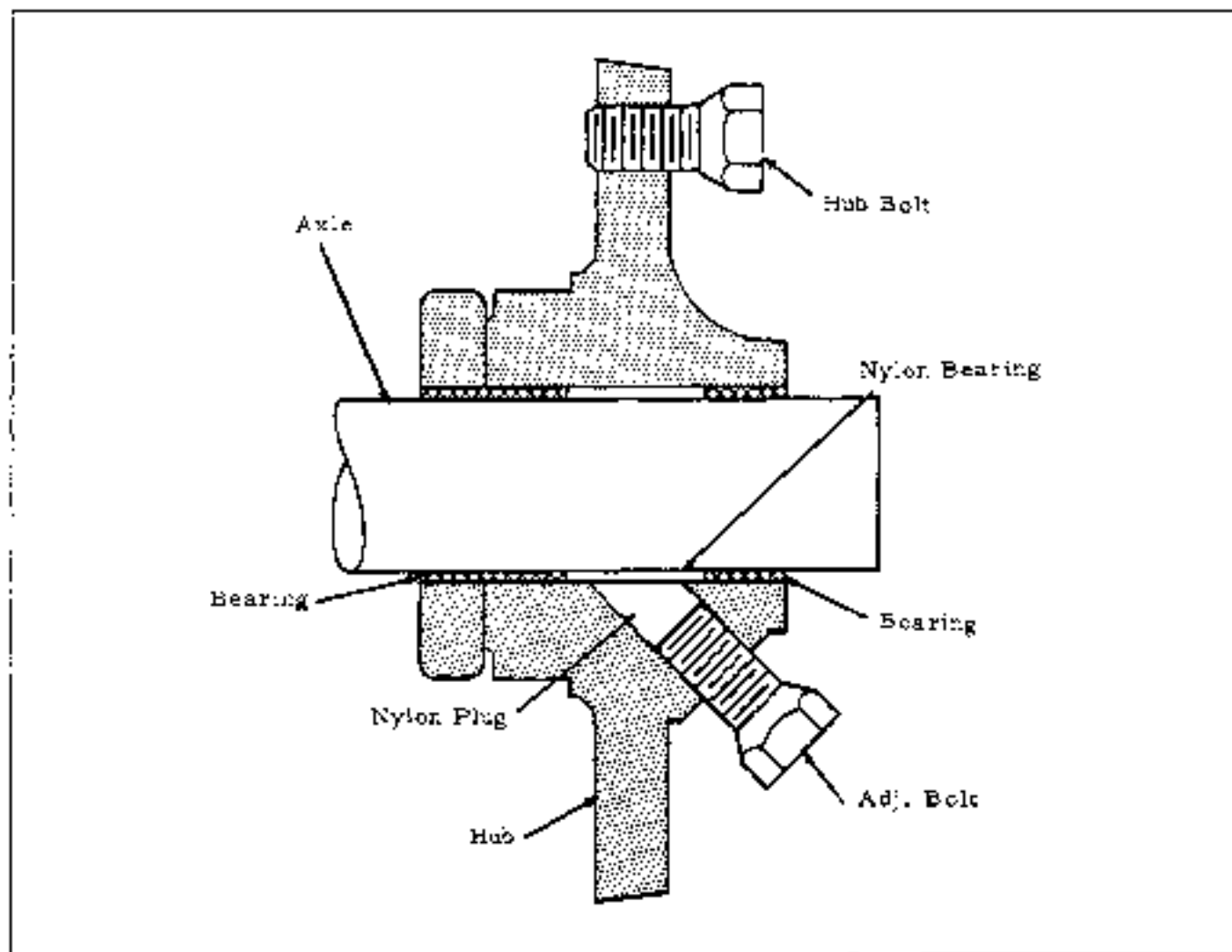

FIG. 2

around the brake drum. Adjust the locknuts to give a clearance of about 11/16" between the brake band and the locknut. Then check to see that the idler pulley releases the belt properly before the brake is applied. If the brake does not hold properly when the pedal is pushed all the way forward, reduce slightly the spacing between the locknuts and the brake band. Now recheck the clutch rod adjustment for proper idler release. (See Fig. 2).

CONTROLLED TRACTION DIFFERENTIAL ADJUSTMENT

All Models



Adjust traction differential within the R. H. rear wheel hub. Adjustment is made by tightening the two capscrews within the R. H. rear wheel hub to 20 ft. lbs.

CAUTION: Maintain 20 ft. lbs. of torque on these capscrews. Under torque will allow excessive wheel slippage under slippery conditions. Over torque will cause hard steering due to lack of differential action.

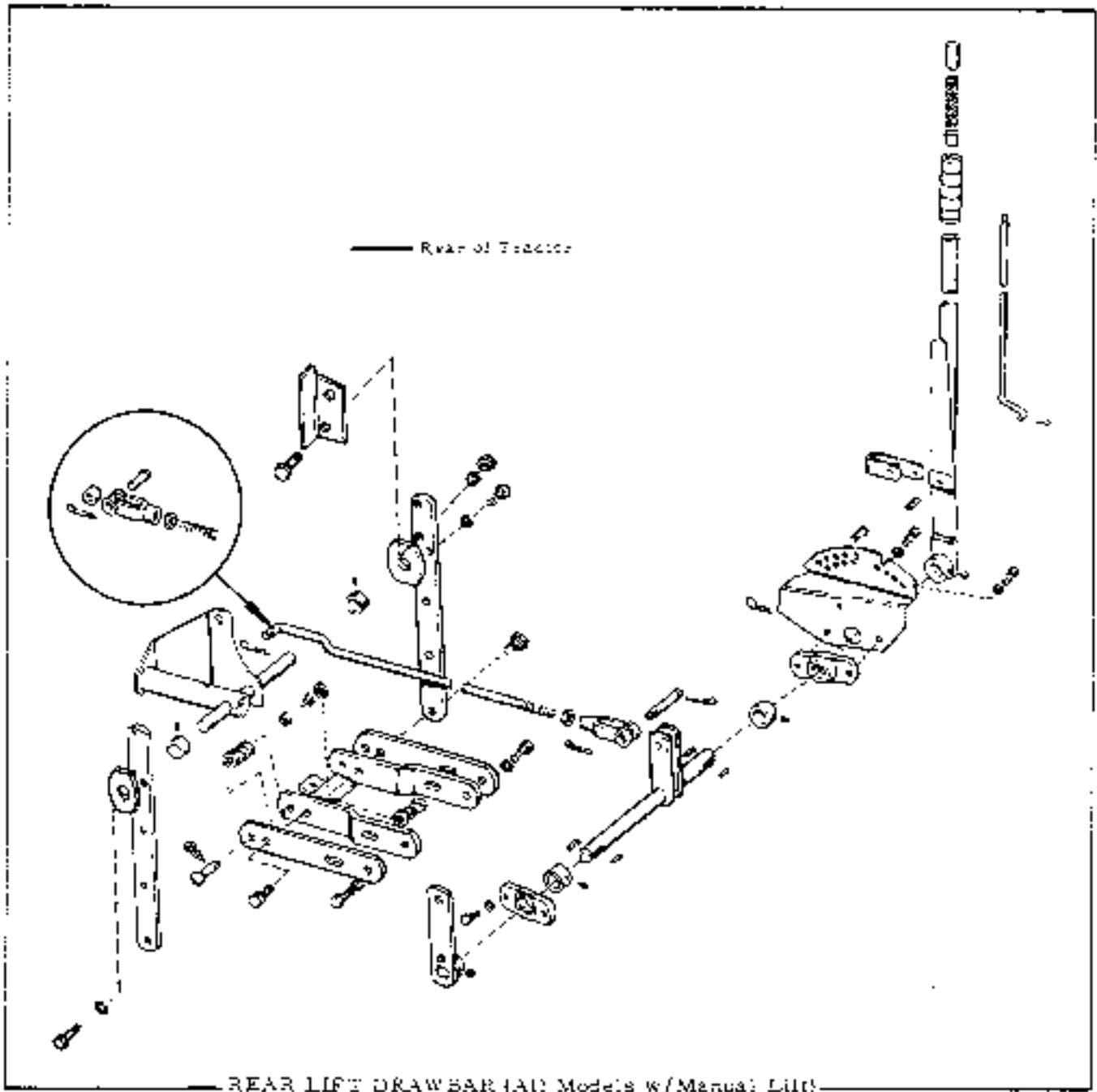

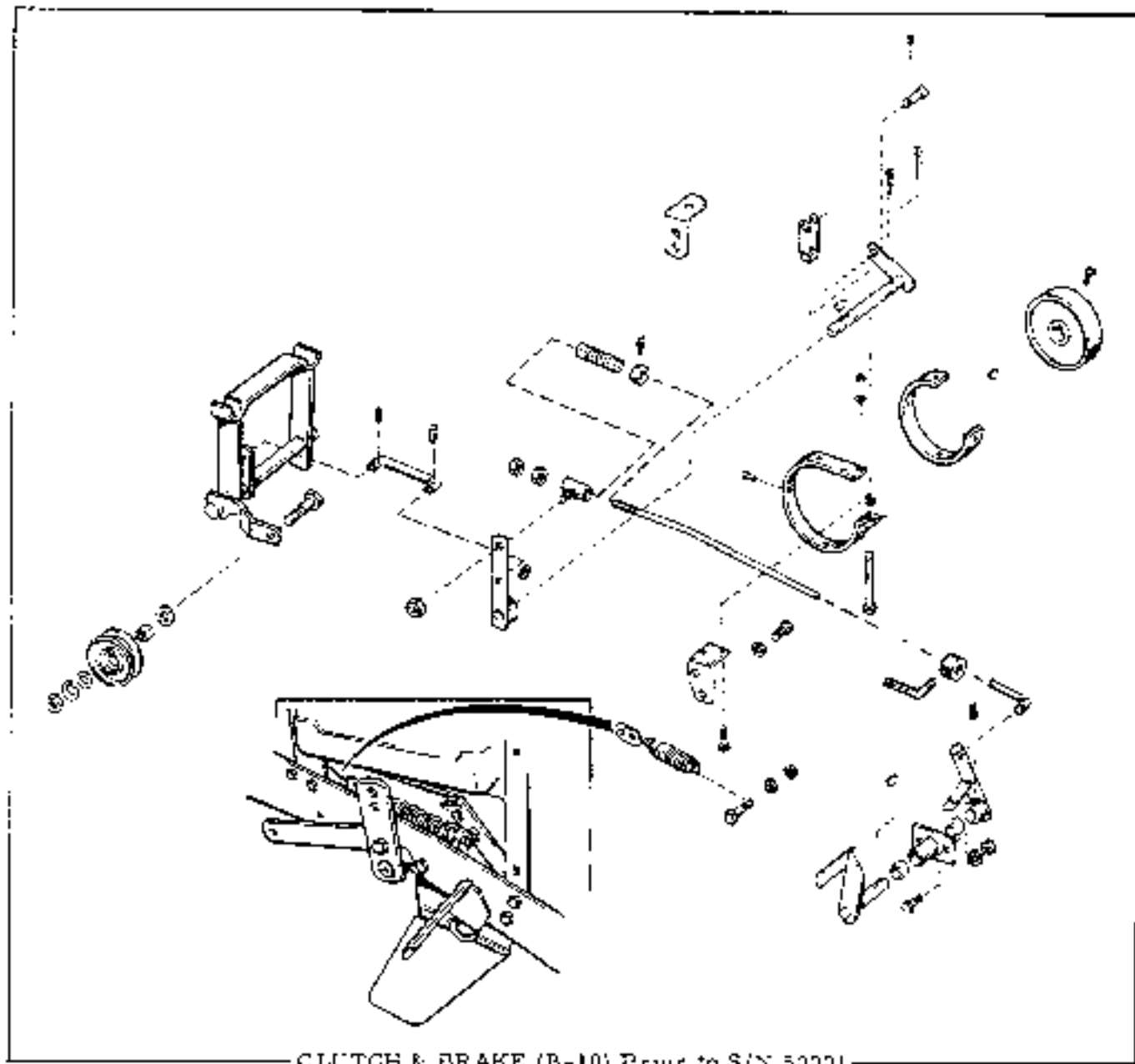

CLUTCH & BRAKE (B-10) Prior to S/N 50001

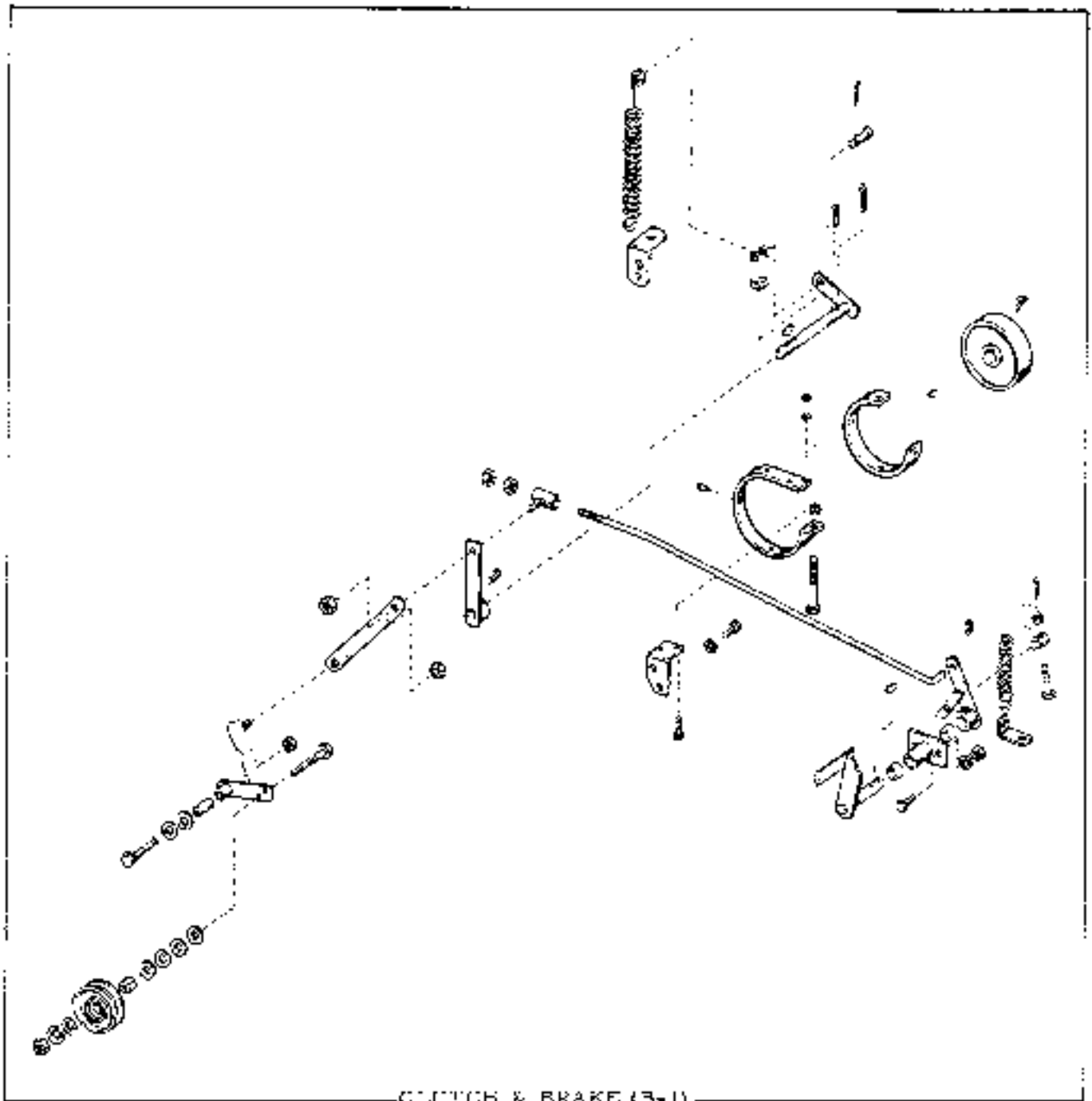

CLUTCH & BRAKE (3-1)

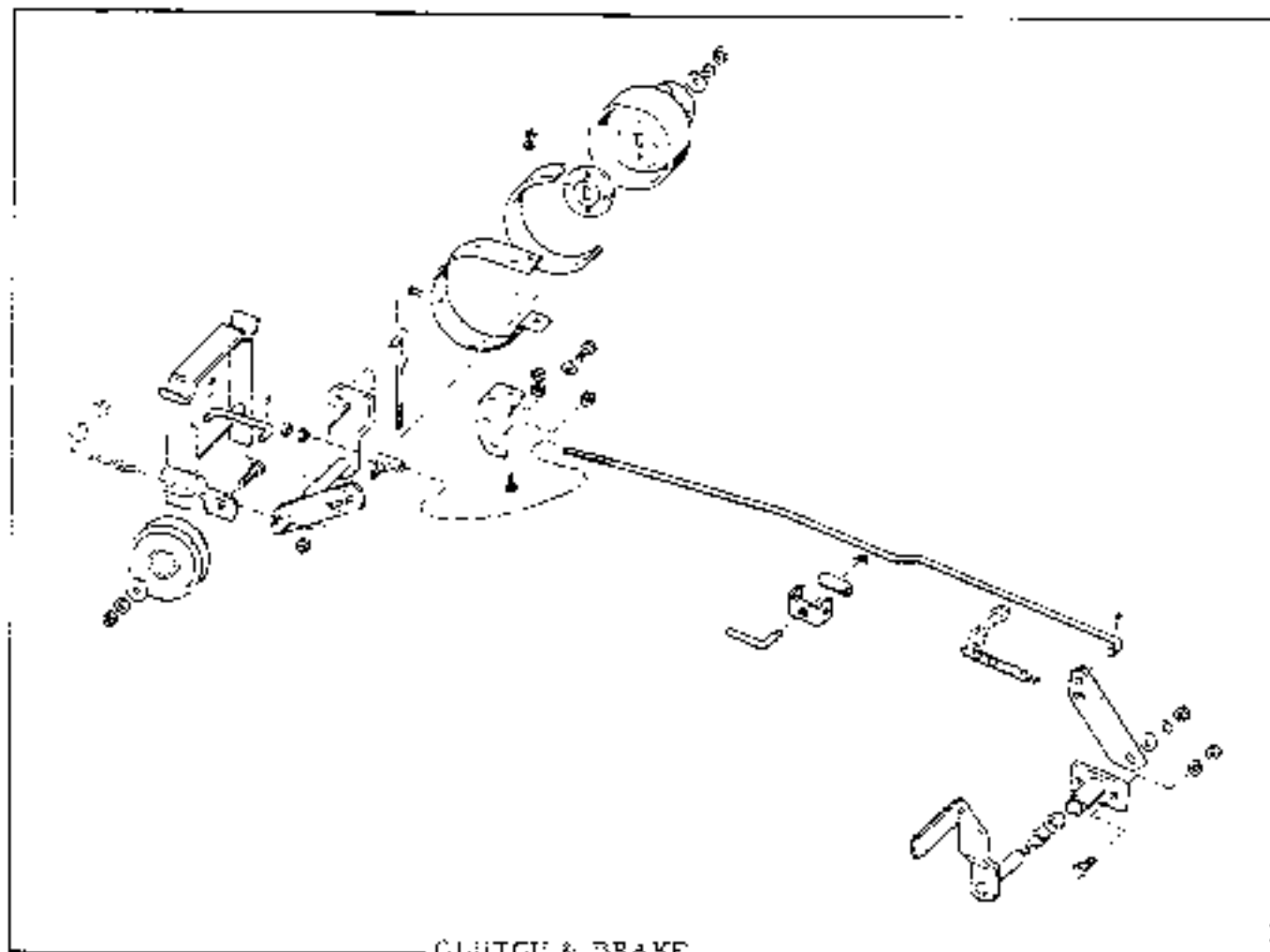

CLUTCH & BRAKE
 Big TEN, B-12, B-10, S/N 50001 & UP, B-110

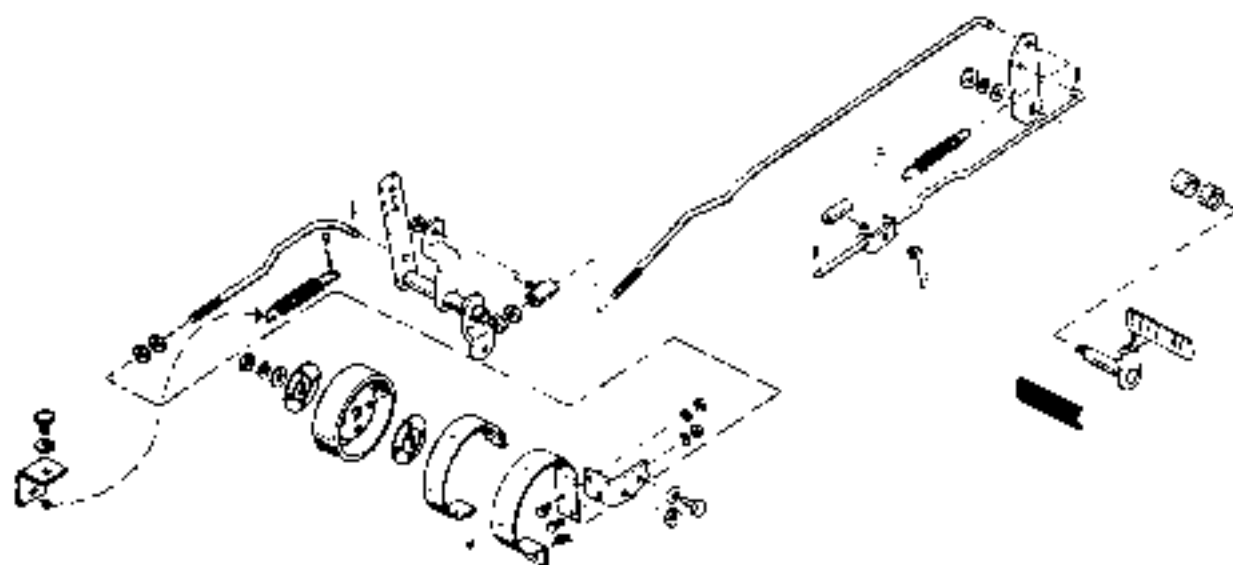

CLUTCH & BRAKE
 (Model B-112 Prior to S/N 20001)

CLUTCH & BRAKE
(Model B-112 Eff, W/S/N 20001 & up)

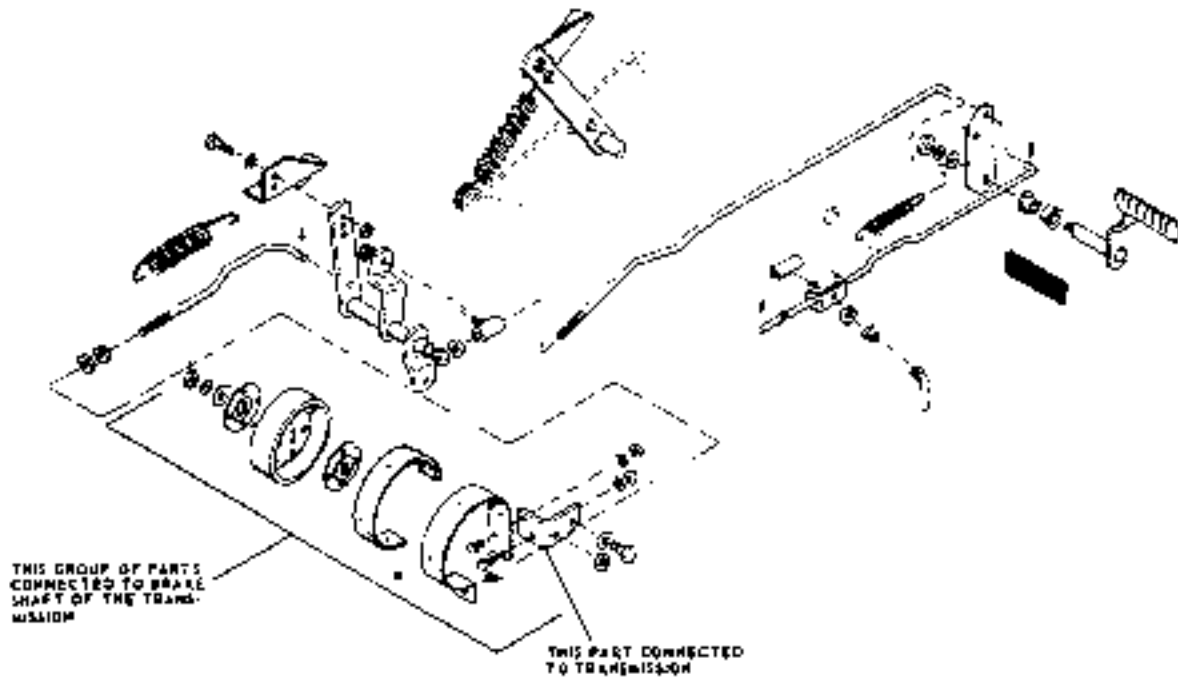

CLUTCH & BRAKE
MODEL HB-112, HB-212

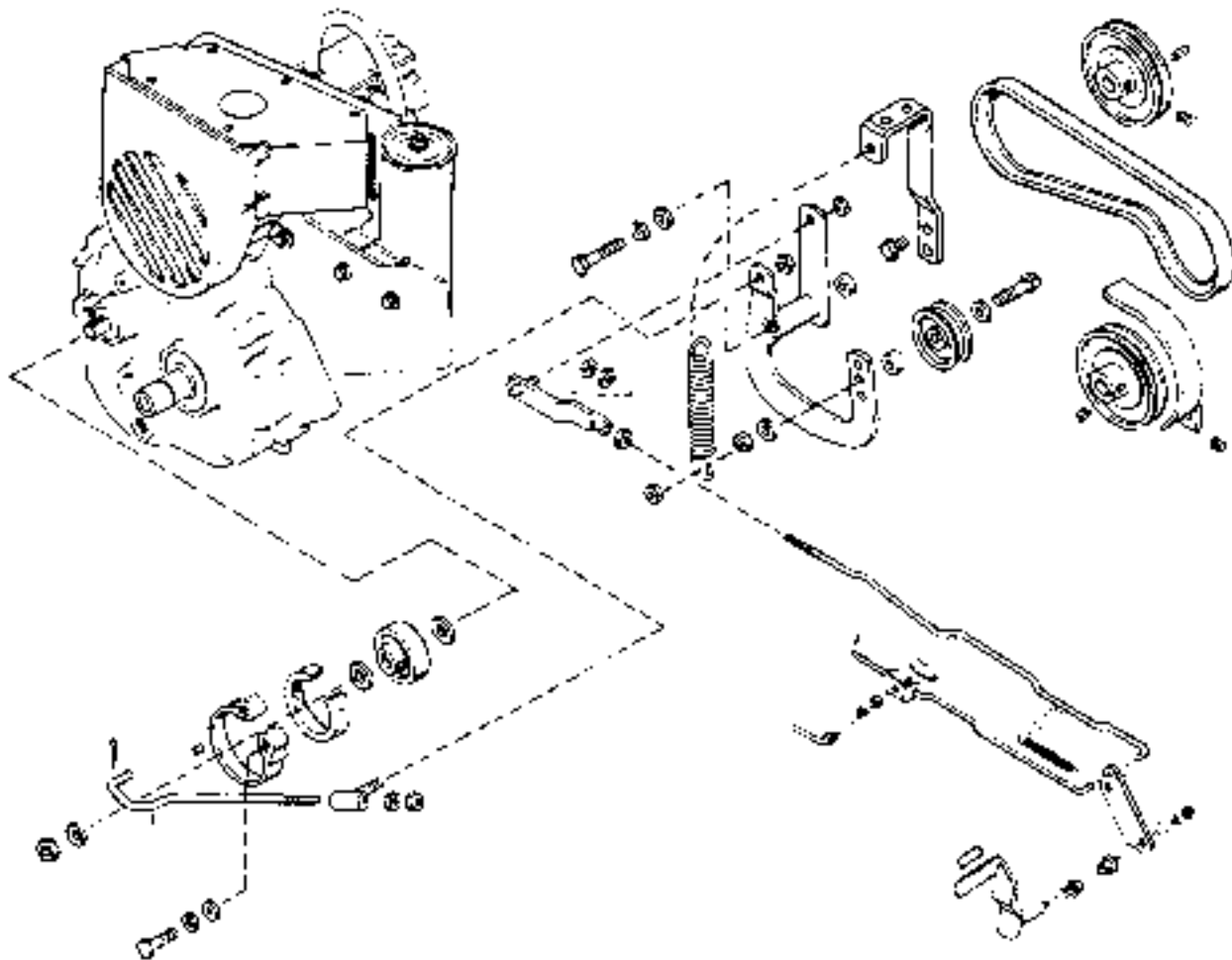

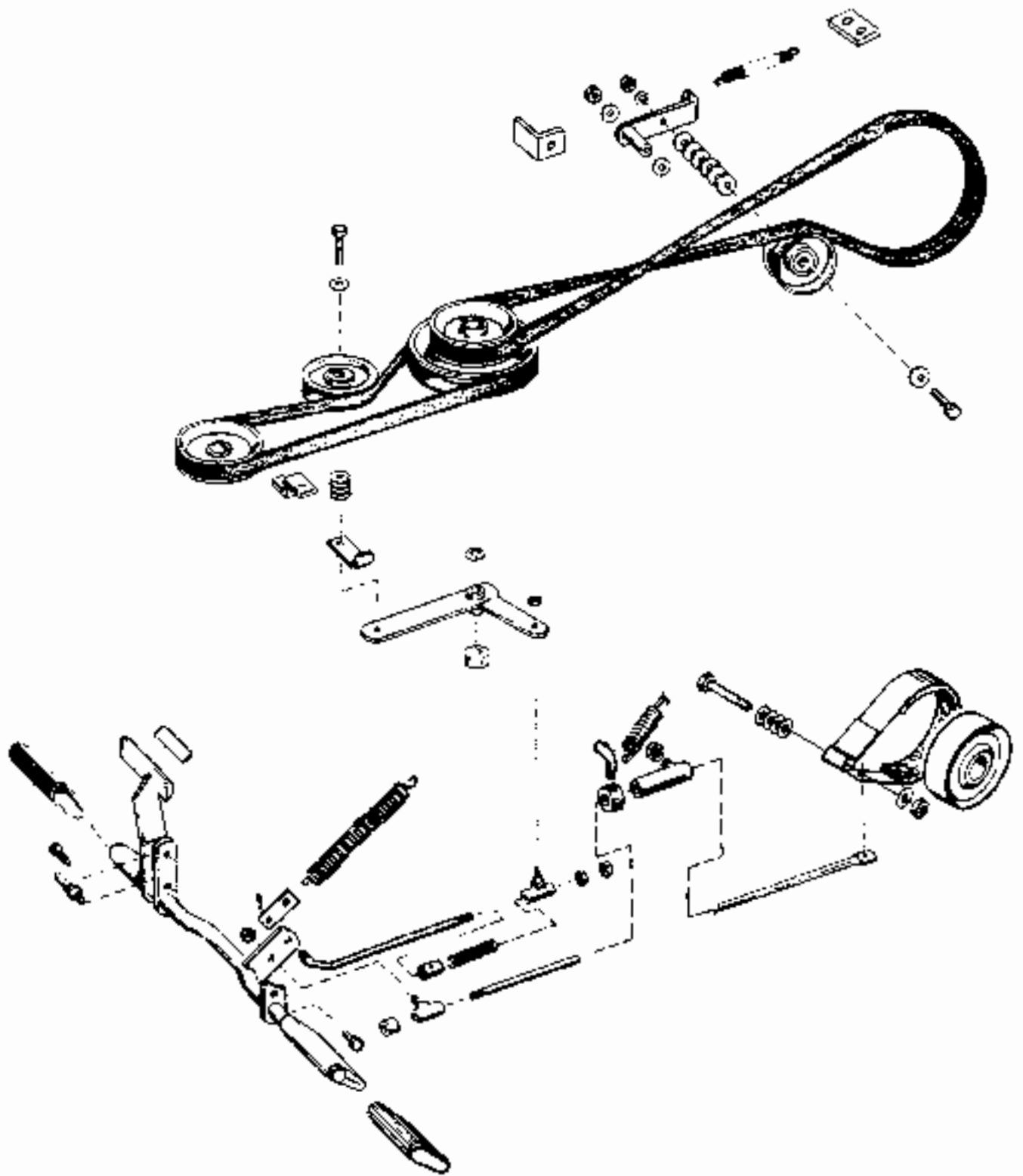

CLUTCH BRAKE SYSTEM.

B-207, B-208

C-21

INDEX

	Page
HYDROSTATIC DRIVE UNIT	
INTRODUCTION	D-1
Purpose of Manual	D-1
Description	D-1
General Information	D-1
GENERAL OVERHAUL PROCEDURES	D-2
DISASSEMBLY	D-2
Tools	D-4
Disassembly of Motor	D-4
Disassembly of Pump	D-7
Disassembly of Valve Plate	D-8
Disassembly of Transfer Block	D-9
INSPECTION AND REPAIR	D-10
ASSEMBLY	D-10
Piston Pump	D-11
Replenishing Pump and Valving	D-11
START-UP AFTER REPAIR	D-11
GENERAL MAINTENANCE	D-11
Lubrication	D-11
Replacement Parts	D-11
Adjustments	D-12
Adding Fluid to System	D-12
Oil Filter	D-12
Troubleshooting	D-12

CHARTS

TRANSMISSION TROUBLESHOOTING GUIDE	D-12
SYSTEM TROUBLESHOOTING GUIDE	D-13

TYPICAL MODEL CODING

T66*-2A+S)-2-10(L)
TA6-2A-S-10*+**
TB6-2A-S-10*+**

THIS PAGE INTENTIONALLY BLANK

SECTION I — INTRODUCTION

A. PURPOSE OF MANUAL

This manual describes the basic operational characteristics and provides service and overhaul information for the Vickers T66 and TA6 Series-10 Design Transmission Packages.

B. DESCRIPTION

Both transmission packages are hydraulic drive assemblies capable of high pressure operation in two directions of flow output. Drive speeds of both transmissions vary with model and circuit applications. Figure 1 illustrates the T66 transmission and its four major components: a variable displacement, reversible piston pump, a transfer block that also houses control valves, and the fixed displacement piston motor.

The TA6 transmission pump and the TB6 transmission motor are composed of identical components of the T66 transmission package except they are not joined by a common transfer block and valve plate.

C. GENERAL INFORMATION

1. Related Documentation — Installation information and dimensions are not contained in this manual. If required, installation drawings are available from your local Vickers Mobile Sales Office.

2. Model Codes — The basic TA6, TB6 and T66 transmission packages are designed and manufactured to meet the requirements of a variety of applications. Optional features are then incorporated to fulfill the operating demands of the particular application. A model code that represents the basic design plus the optional features is assigned to each model. To identify the specific design characteristics of your transmission, copy the model number stamped on the back side of the transfer block. For a breakdown of the code refer to the TA6 installation drawing, or the T66 installation drawing.

Be sure to include the complete model number and date code when addressing service inquiries to Vickers. This will help to provide prompt and accurate answers to your inquiry.

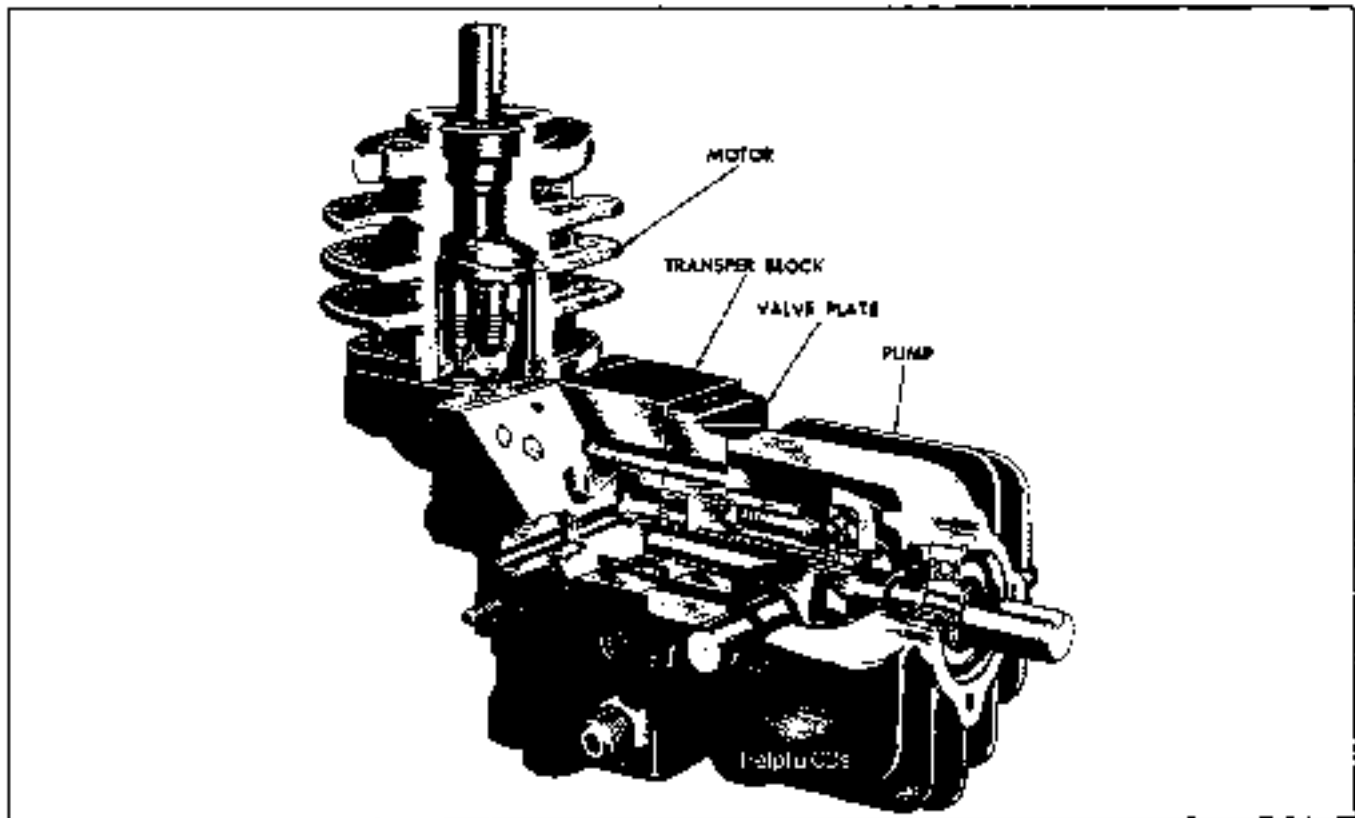

Figure 1

SECTION II — GENERAL OVERHAUL PROCEDURES

CAUTION

Block vehicle if it is on a slope. The transmission cannot act as a parking brake.

Before breaking a circuit connection, make certain that the power is off and the system pressure has been released.

Lower all vertical cylinders, discharge all accumulators, and block any load whose movement could generate pressure.

Completely drain the oil from the vehicle hydraulic system. Discard this oil and use new, clean oil when restoring the unit to service.

After removing the hydrostatic transmission from the vehicle, and before disassembly, cap or plug all ports and disconnected hydraulic lines, and clean the outside of the unit thoroughly to prevent entry of dirt into the system.

CAUTION

Absolute cleanliness is essential when working on a hydraulic system. Always work in a clean area. The presence of dirt and foreign materials in the system can result in serious damage or inadequate operation.

SECTION III — DISASSEMBLY

The exploded views of the assemblies in Figures 2, 3, 4 and 5 are provided as additional visual aids that support the sequential disassembly procedures that follow. Both the T66 and TA6 transmission are composed of identical assemblies, except the TA6 is not equipped with a motor. The motor disassembly procedure can obviously be disregarded when working on the TA6 transmission. Also, only disassemble the

transmission to the level that is necessary to repair the unit.

NOTE

Keep parts for each unit clean and separate from those of another unit or assembly. Although some parts may look similar they could have slightly different and critical dimensions.

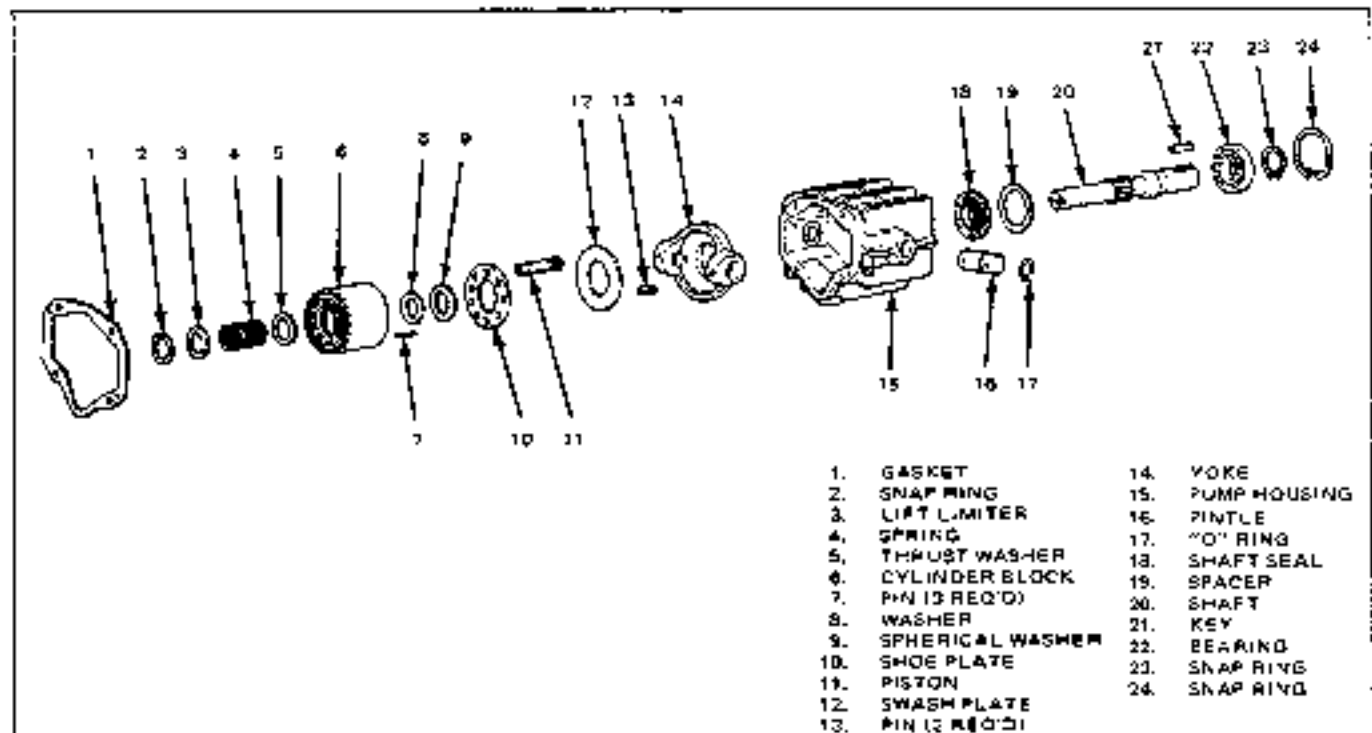

Figure 2 T66 and TA6 Pump

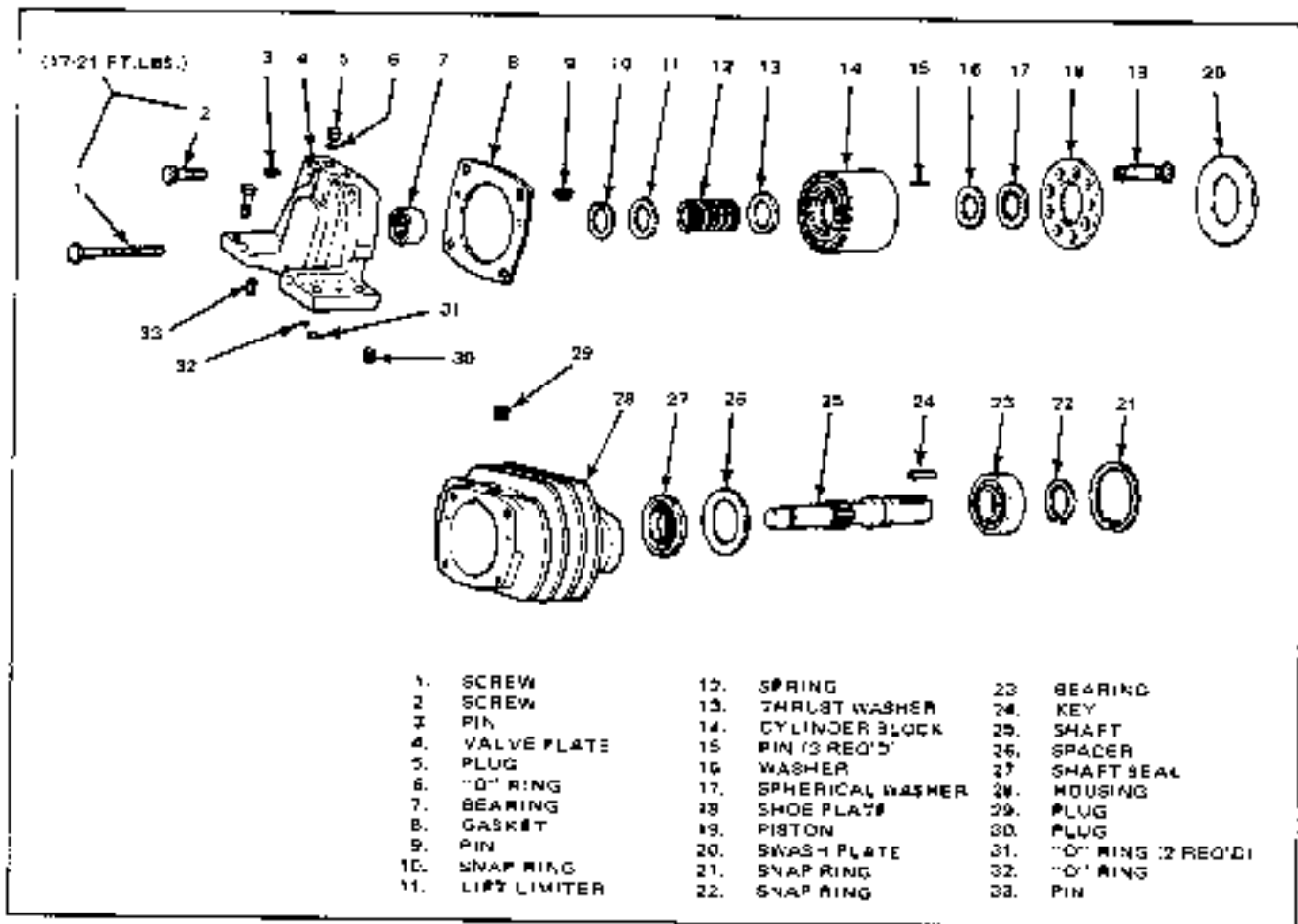

Figure 3 T66 Motor

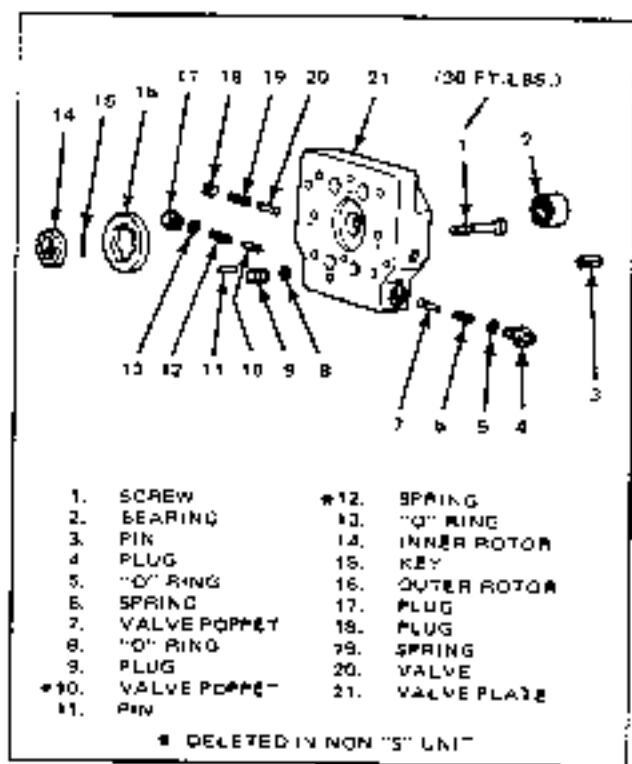

Figure 4 T66 and TA6 Valve Plate Assembly

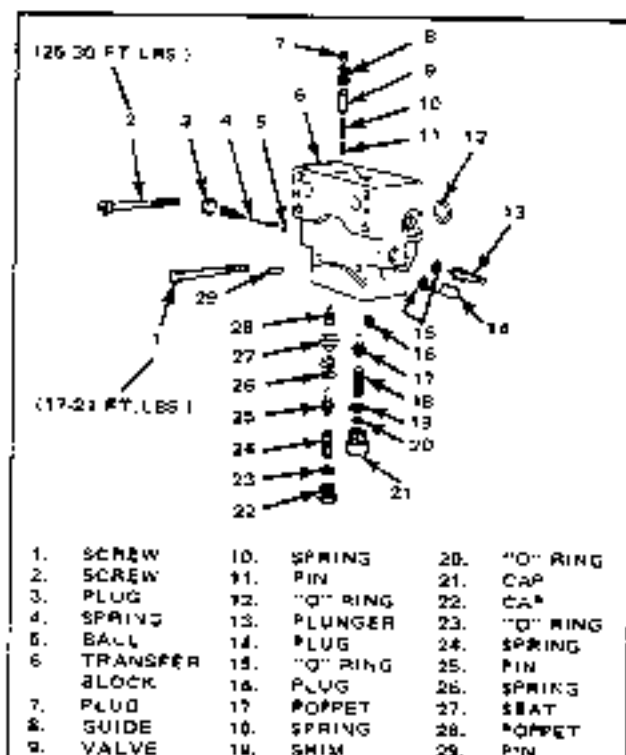

Figure 5 T66 and TA6 Transfer Block Assembly

TOOLS

Figure 6 illustrates the recommended set of tools that are used during disassembly or reassembly. Some equivalent tools are noted in the instruction.

1. Bearing puller
2. Shaft seal driver
3. Bearing puller
4. Torque wrench (150 ft-lb)
5. No. 5 Truarc (90°) pliers
6. No. 24 Truarc (straight) pliers
7. No. 23 Truarc (90°) pliers
8. No. 22 Truarc (90°) pliers
9. No. 21 Truarc (straight) pliers

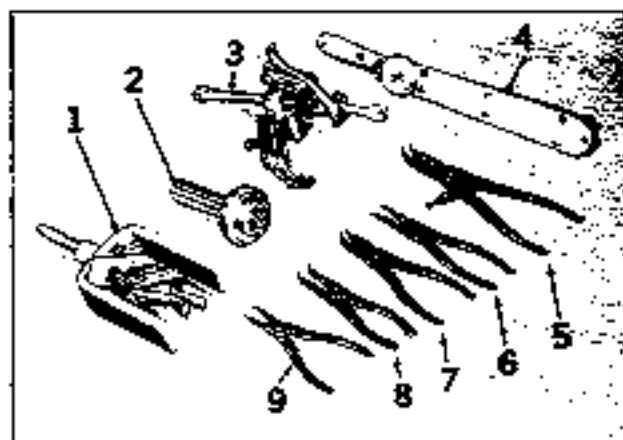
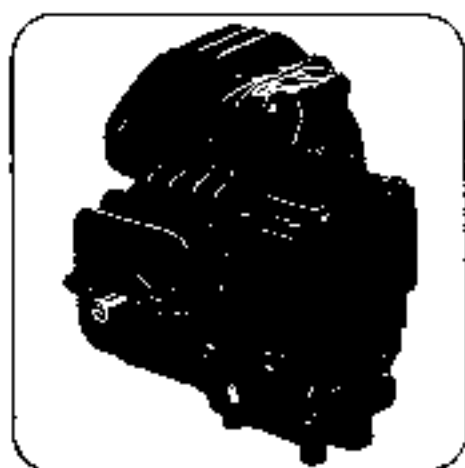
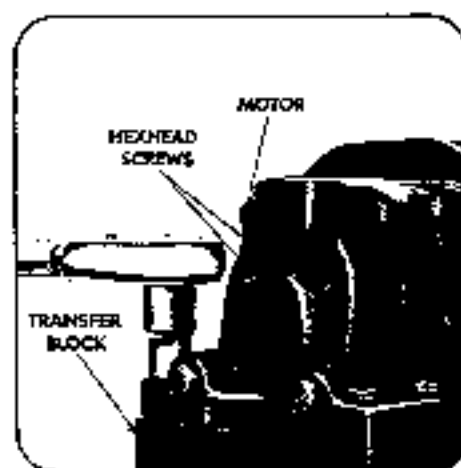

Figure 6

DISASSEMBLY OF MOTOR



Place the transmission on a clean workbench. Have a supply of clean, lint-free rags, shop paper, or craft paper handy to lay parts on and to cover parts from dirt and foreign particles.



Separate the motor assembly from the transfer block by removing four hex head screws. Discard "O" rings and replace with new ones.

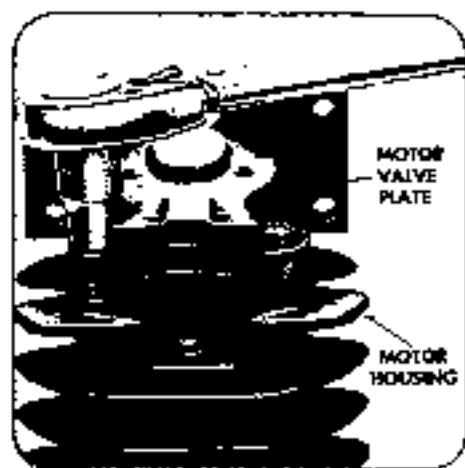

Separate motor valve plate from the motor housing by removing four screws.

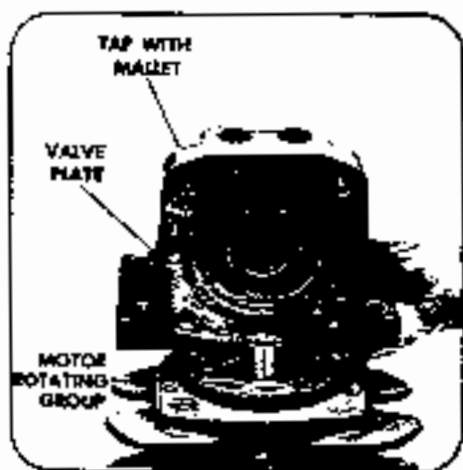

If valve plate doesn't separate easily from motor housing, tap corner of valve plate with plastic mallet.

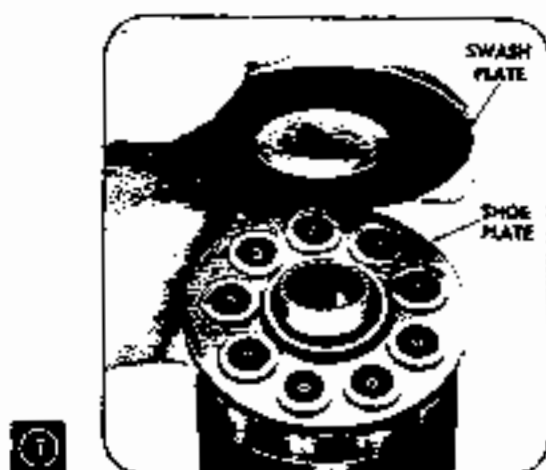

Remove swash plate from shoe plate.

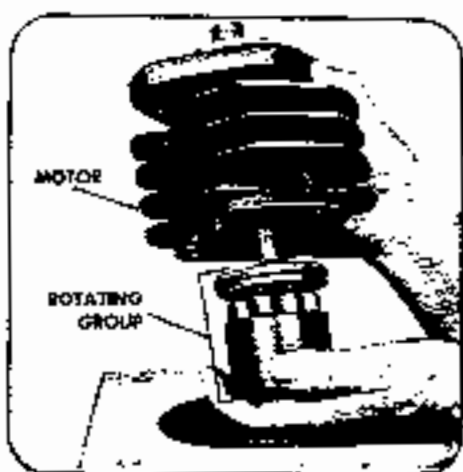

With one hand under rotating group end, tilt housing until rotating group slides into your hand.

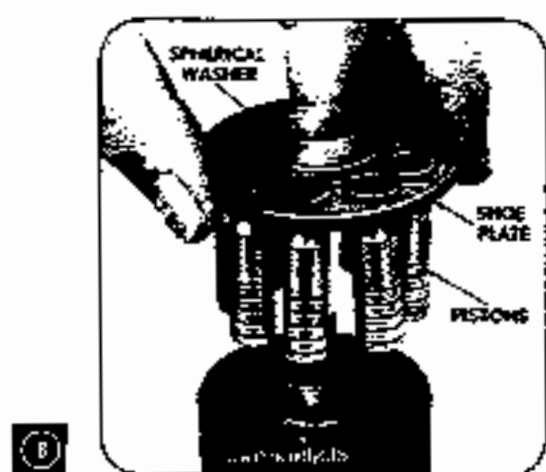

Remove assembled parts as shown. Be careful not to scratch the pistons or cylinder running surfaces.



If this group does not need to be disassembled, place it on a clean surface and proceed to step 14. To disassemble this group proceed to step 8.

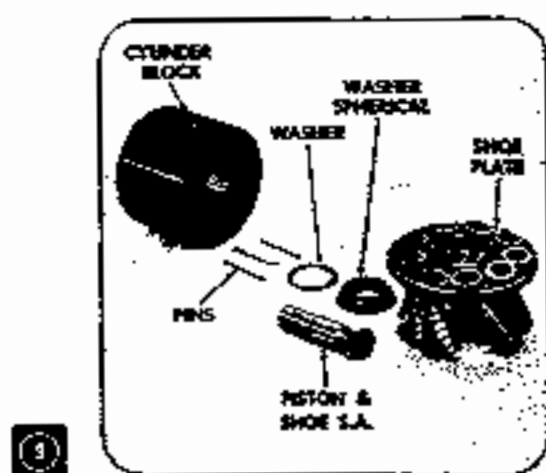

Generally, no further disassembly is required. However, if the cylinder block is to be disassembled, proceed to step 10.

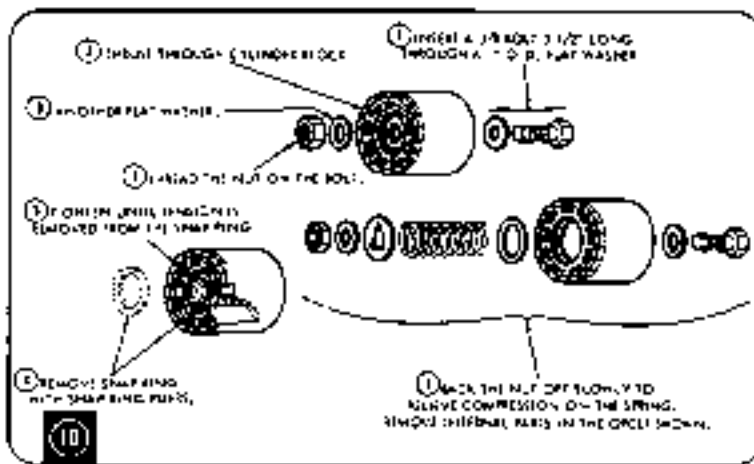

To relieve cylinder block spring tension, refer to Figure 10. **WARNING**—exercise extreme caution. Spring is under a great deal of tension.

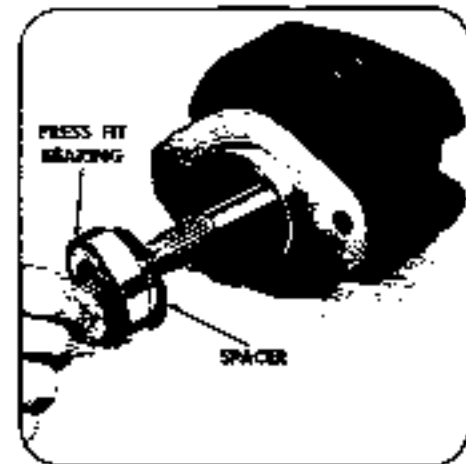

Remove shaft. The spacer and press fit bearing should come out with it. Replace shaft seal.

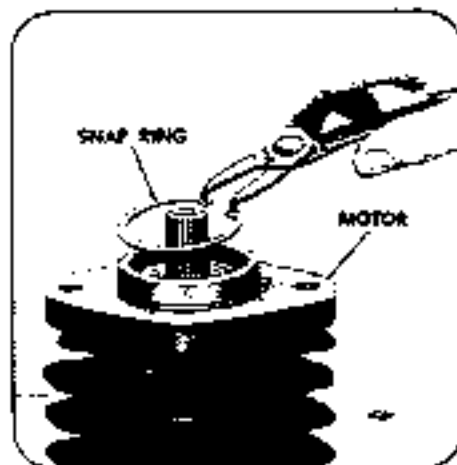

To remove the motor shaft, first remove the large snap ring with the 90° Truarc pliers.

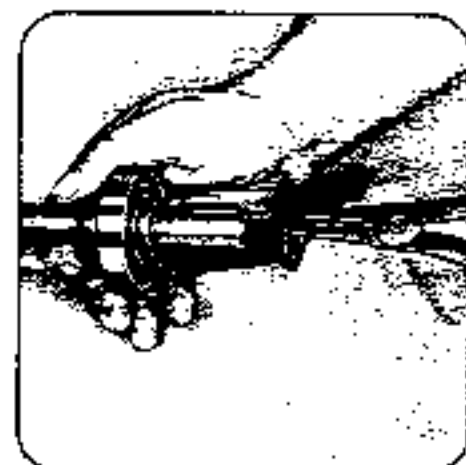

Remove snap ring and key from motor shaft before you remove the bearing.

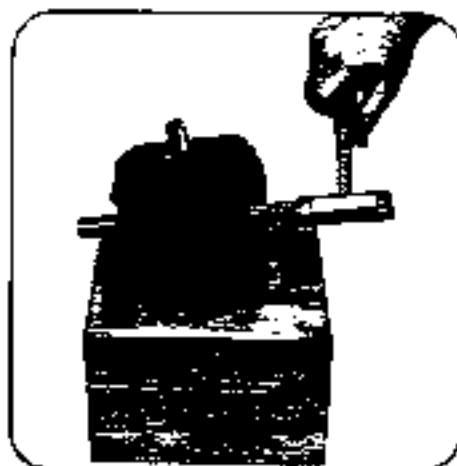

Remove the shaft by tapping on the small end with a soft-tipped hammer or mallet.



If it is necessary to remove the bearing, first remove the key; then use an Owatanna 10-11 bearing puller, or equivalent puller, or an arbor press. Any other method of removal may damage bearing.

DISASSEMBLY OF PUMP

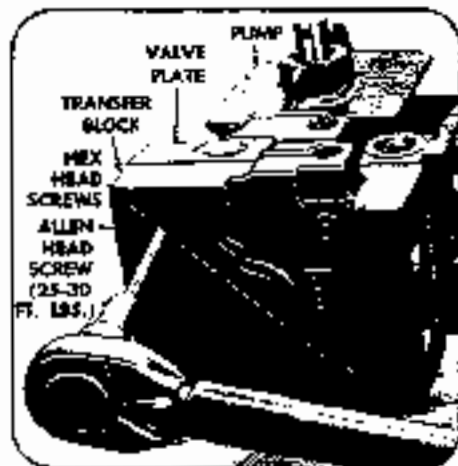

16

To disassemble the pump, remove the valve plate and transfer blocks as a unit by removing two recessed Allen head screws, and then the two hex head screws.

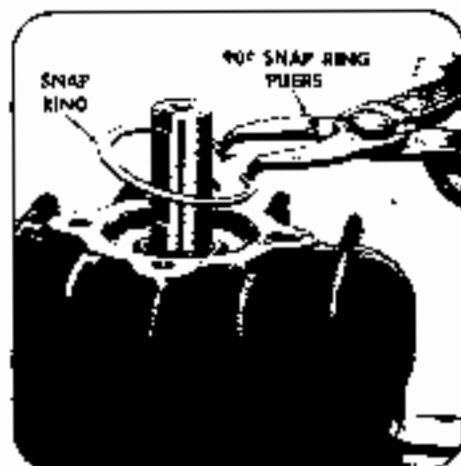

17

Now to remove the pump shaft. First remove the snap ring with 90° snap ring pliers.

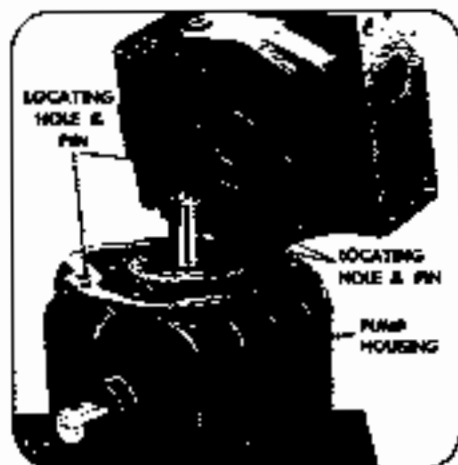

18

Pull valve plate and transfer block straight up from pump housing. Set it down on its painted side. Assembly Note: Line up pins with holes in valve plate and gerotor key with drive shaft slot.

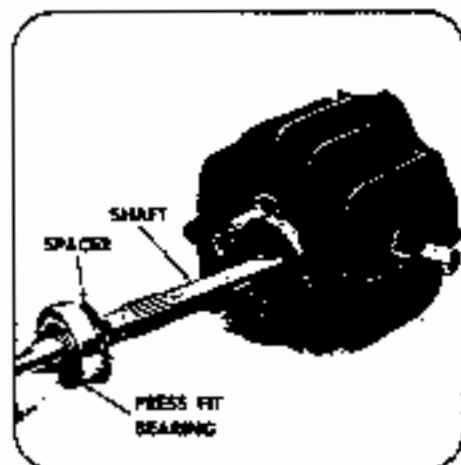

19

Remove the pump shaft by tapping the small end of the shaft with a plastic tip hammer. Remove the shaft with the loose spacer and the press fit bearing installed on it. Replace shaft seal.



20

Pick up pump housing with one hand and slowly tilt it forward to remove group as assembled unit. To disassemble rotating group perform steps 7 thru 10.

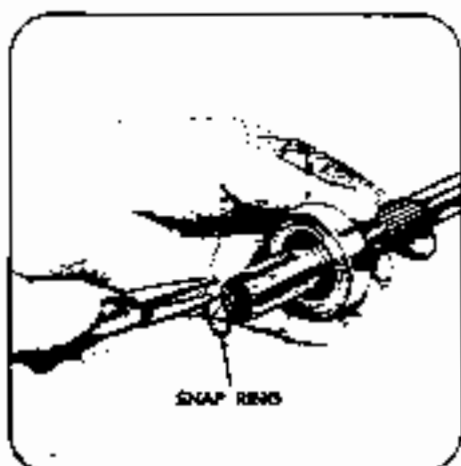

21

To remove the bearing, remove the key, and then the snap ring. Refer to step 15 for bearing removal.

DISASSEMBLY OF VALVE PLATE

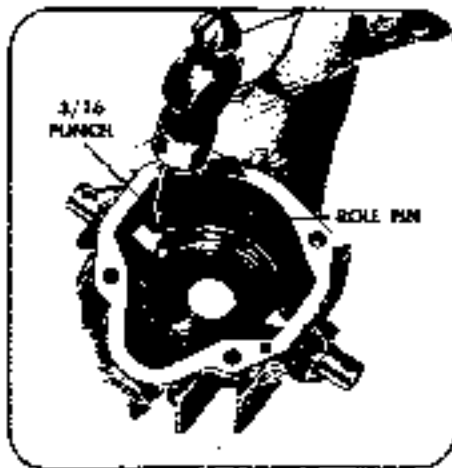

21

To remove both pintles and yoke from the housing, set a 3/16-inch punch on the roll pin. Tap punch with a hammer until roll pin is disengaged from yoke.



22

To disassemble the valve plate, remove the two recessed Allen-head screws.

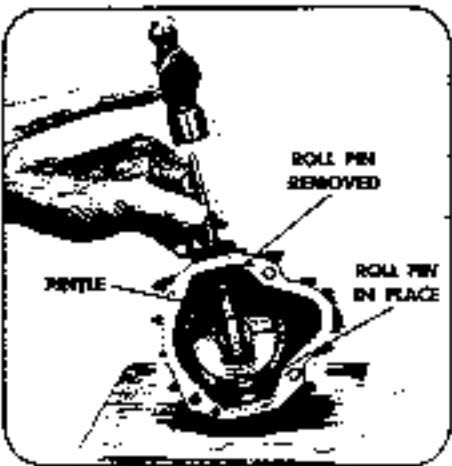

23

Now place a 1/4-inch brass rod on the pintle, and tap the pintle out of the yoke.

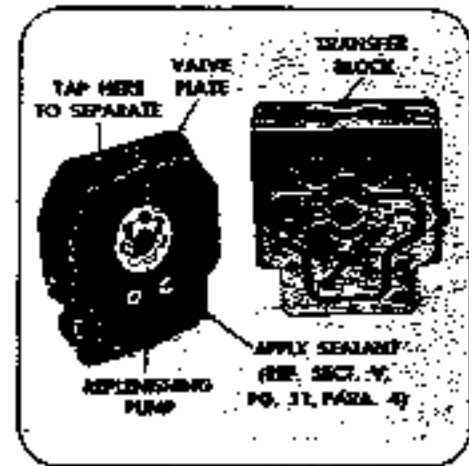

24

Separate valve plate from transfer blocks by pulling them apart. If required, tap valve plate with a plastic mallet to separate them.

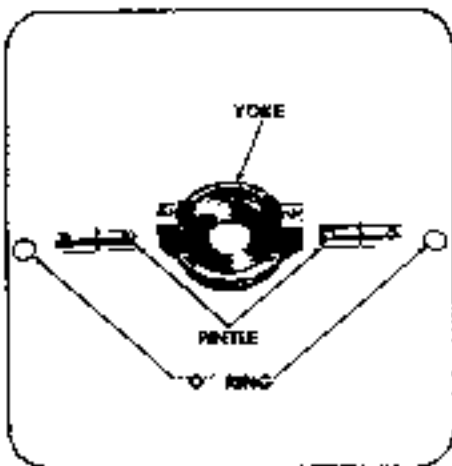

25

Repeat this procedure on the other pintle. Remove yoke from housing. Pintles must not be installed backward.



26

Remove replenishment pump from valve plate. Assembly Note: Dots not to be visible when replenishing pump is in pocket.

DISASSEMBLY OF TRANSFER BLOCK

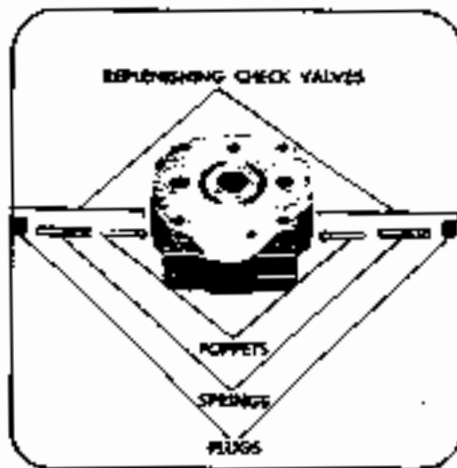

8

Remove the two replenishing system check valves by removing the Allen-head plugs. Don't interchange valve parts.

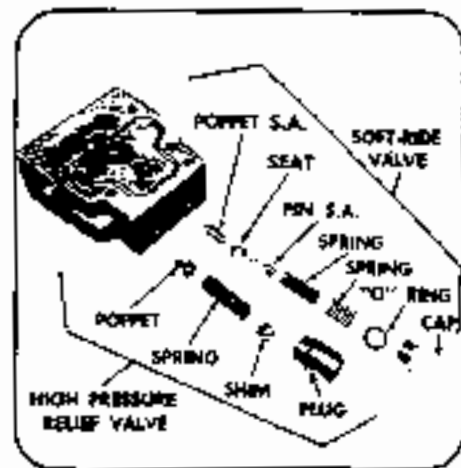

9

Set transfer block with finished surface facing up. Remove caps and take out both the soft-ride valve and high-pressure relief valve.

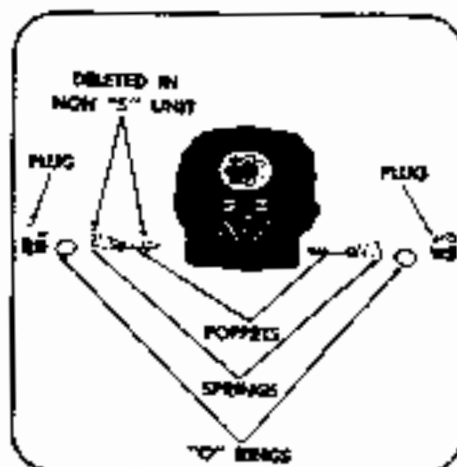

10

Remove replenishing pump relief valve. (Some models have only one valve.)

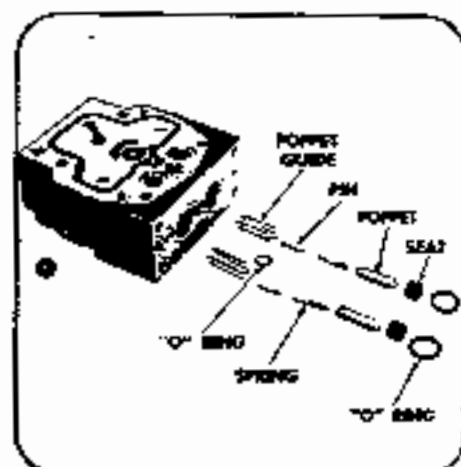

11

To remove high pressure check valves, first remove three "O" rings. Assembly Note: Be sure open ends of guide point outward.



12

To remove bearing, place valve plate on protective surface. Put brass shim stock or other protective stock under puller. Use Owatanna MD956-B-1, an equivalent puller, or an arbor press.

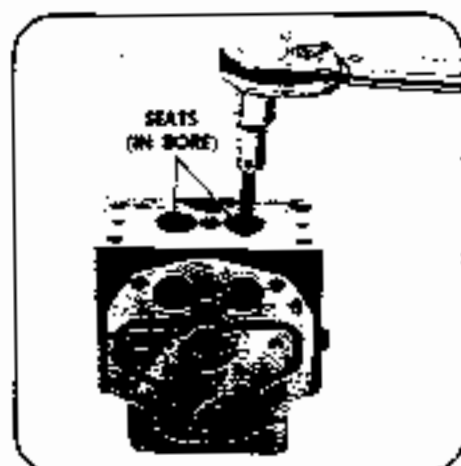

13

Remove high-pressure check valve seats with an Allen-head wrench. Assembly Note: During assembly, torque valve seats to 30-35 ft-lbs.

SECTION IV — INSPECTION AND REPAIR

Clean all parts thoroughly with mineral spirits prior to inspection and after any stoning or machining operation. Inspection and repair procedures are as follows:

1. **Valve Plate** — Inspect the flat surface mates with the cylinder block for wear or scoring. Remove minor defects by lightly stoning the surface with a hard Arkansas stone that is flat within 0.001 inch. Be sure to stone lightly; the surface is hardened and excessive stoning will remove hardened surface. If wear or damage is extensive, replace the valve plate.

2. **Rotating Group** — Inspect the bores and the valve plate mating surface of the cylinder block for wear and scoring. Remove minor defects on the running face by lightly stoning or lapping the surface. If the defects cannot be removed by these methods, replace cylinder block.

If one or more piston and shoe sub-assemblies need to be replaced, check that all piston and shoe subassemblies in the unit ride properly on the swash plate (Figure 7). In a set of nine pistons, variations in thickness greater than 0.001 of an inch from one shoe to another, will result in excessive internal leakage and shoe wear. The replacement of all nine piston and shoe sub-assemblies in the pump and motor, as well as the cylinder block, is recommended for maximum service between overhauls.

If necessary, hand-lap the shoes with 500-A emery paper (Tuff-Bak Durite Silicon Carbide) backed-up by a lapping plate. Good results may be obtained by dipping the emery paper in kerosene and keeping it wet during polishing.

SECTION V — ASSEMBLY

The procedures for assembling the transmission are basically the reverse of the disassembly procedures shown in detail in Section 3. However, the following instructions describe certain additional procedures that should be adhered to:

Install new gaskets, seals, and "O" rings during assembly. To ease assembly of the gaskets and seals, apply a thin film of Vaseline or clean hydraulic oil to the "O" rings. If a new

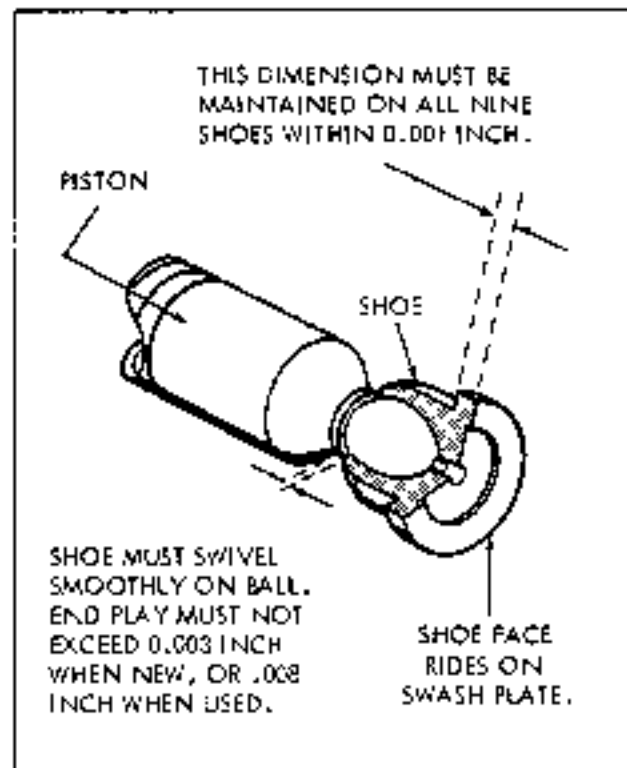

Figure 7

3. **Swash Plate** — Inspect the swash plate for wear and scoring. If the defects are minor, lightly stone the swash plate. If wear or damage is extensive, replace the swash plate.

4. **Bearings and Drive Shaft** — Inspect all bearings for roughness or excessive play; replace if necessary. Examine the sealing area of the shaft for scoring or wear. If the drive shaft is bent or worn excessively, replace it.

5. **Replenishing Pump** — Inspect the surface of all parts subject to wear. Remove light scoring from the face of the inner and outer rotor with crocus cloth laid over a flat surface, with a medium India stone, or by lapping.

rotating group is being used, squirt clean oil on it.

PISTON PUMP

1. **Yoke** — Install the yoke in the housing. With "O" rings in place, insert the pintles through the housing and into the yoke. Check that the yoke does not rub against the housing. Align the pintle holes with the holes in the yoke. Press in roll pins until they are 0.10 inch from top of yoke.

2. **Drive Shaft and Bearing** — Install new shaft seal in the housing. Place the flat washer over the shaft seal. Then install the drive shaft in the housing. Secure the drive shaft bearing with the retaining snap ring.

3. **Swash Plate** — Install the chamfered edge of the swash plate toward the shaft seal. Be sure that the swash plate is properly seated in the yoke and that it can be freely rotated with the fingers.

4. **Rotating Group Assembly** — If the spring and washers were removed from the cylinder block, reassemble them. When properly assembled with the three pins in place, the spring can be compressed about 1/8 inch.

REPLENISHING PUMP AND VALVING

1. Carefully install the inner and outer rotor elements (with key in key slot) into the valve plate. The key must mate with the slot on the drive shaft and must be installed on the side of the rotor that is toward the drive shaft.

2. Oil the cartridge with clean hydraulic oil for prelubrication. The key can be coated with Vaseline to hold it in place during assembly.

3. Be sure the locating pins are in the valve plate, and that the "O" ring seals are in place.

4. New sealant must be applied to the valve plate before reassembly. Remove all old sealant and residue with lacquer thinner or acetone on a cloth. Purchase Ford Perfect Seal (8A-19554-B) R134-A from a local Ford Dealer or purchase Sealing Compound Grade No. 4 direct from P. & O. B. Mfg. Co., 11100 Kenwood Road, Cincinnati, Ohio—Phone (513) 793-6332.

Apply sealant compound on valve plate approximately 0.38 wide around perimeter, then proceed with assembly (See Illustration 26)

5. **Assemble Remaining Parts** — Relief valve, springs, "O" ring seals and plugs. (Refer to exploded views and photos for details.)

SECTION VI — START-UP AFTER REPAIR

Take the following precautions when starting a vehicle after repair:

1. Before connecting drain lines and before installing transmission in vehicle, fill transmission pump and motor with new, clean oil through case drain openings.

2. Connect all hydraulic lines to the proper transmission port lines and set hydraulic controls in neutral position.

3. Loosen or remove reservoir cap and add new, clean oil to reservoir.

4. Jog the starter several times (about one minute) with engine coil wire disconnected. Recheck reservoir oil level. If necessary, add oil to maintain operating oil level.

5. Replace engine coil wire. Start the engine and run it to a speed of about 800 rpm

(avoid high speed start-up). Recheck reservoir oil level again.

6. Increase pump speed to 1800 rpm and move the controls to the forward position and run vehicle slowly on level ground for a few yards.

7. Then, after a short interval (about 10 seconds), place controls in reverse and move vehicle slowly backwards an equal distance.

8. After several short trips back and forth, the air should be dispelled from your hydraulic system. Check oil level; add oil if necessary.

After all the above steps are complete, you may operate the vehicle at regular speeds and loads. In cold weather, make sure the hydraulic components are warm to the touch before operating the vehicle.

SECTION VII — GENERAL MAINTENANCE

LUBRICATION

Internal lubrication is provided by the system oil flow.

REPLACEMENT PARTS

Use only genuine parts manufactured or sold by Vickers Incorporated as replacement

parts for these transmissions. Only Vickers knows the true quality level required of each part.

ADJUSTMENTS

No periodic adjustments are required other than maintaining proper shaft alignment with the driving medium.

ADDING FLUID TO THE SYSTEM

When adding hydraulic fluid to the system, pour it through a 10-mikron filter. If such a filter is not available, use a funnel with a fine wire screen (200 mesh or better).

OIL FILTER

The oil filter controls the cleanliness of the oil. Experience with various kinds of duty and operating conditions will help you to determine how often to schedule a filter cartridge change. Check the condition of the oil periodically until you can establish a replacement pattern. In the

meantime, change the cartridge after the first 50 hours of vehicle operation.

TROUBLESHOOTING

The cause of improper functioning in a hydraulic system is best diagnosed with the use of proper and adequate testing equipment and a thorough understanding of the complete hydraulic system.

CAUTION

A hydraulic transmission unit that exhibits an excessive increase in heat or noise is a potential failure. When either of these conditions are noticed, immediately shut down the machine, locate the trouble, and correct it.

Detailed troubleshooting information is given in the following charts.

TRANSMISSION TROUBLESHOOTING GUIDE

Has Malfunction Been	Probable Cause	
	Code	Code Legend
Steady?	1, 2, 3, 4, 5, 6, 7, 8	1. Charge system 2. Inlet check valve 3. Pump rotating group 4. Motor rotating group 5. High-pressure check valves 6. Soft-ride valve 7. High-pressure relief valve 8. Tow valve
Intermittent?	6	
In one direction of travel?	2, 4, 5	
In both directions of travel?	1, 3, 4, 6, 7, 8	
Occurring under light load?	2, 5, 6, 8	
Occurring under heavy load?	1, 2, 3, 4, 5, 6, 7, 8	
Independent of load?	1, 3, 4, 6, 7, 8	
Occurring at maximum vehicle speed?	1, 4	
At minimum vehicle speed?	1, 3, 4	
Independent of vehicle speed?	1, 2, 5, 6, 7, 8	
Occurring at wide open throttle?	3	
Occurring at partial throttle?	1, 3, 5, 8	
Independent of throttle?	1, 2, 3, 4, 5, 6, 7, 8	
Occurring when system is hot?	1, 3, 4, 6	
When system is cold?	1, 6	
Independent of temperature?	1, 2, 3, 4, 5, 6, 7, 8	
Deteriorating rapidly?	3, 4, 5, 6, 7, 8	
Deteriorating slowly?	1, 2, 3, 4, 5, 6	

SYSTEM TROUBLESHOOTING GUIDE

Trouble	Cause	Remedy
I. Excessive noise in hydrostatic transmission	Air in the system	<ol style="list-style-type: none"> 1. Check for air leaks on suction line. 2. "Bleed" hydraulic lines at highest point downstream of replenishing pump and while system is under pressure.
	Vacuum condition	<ol style="list-style-type: none"> 1. Check inlet (suction) lines and fittings for air leaks 2. Check replenishing pump function.
	Oil too thick	Be certain correct type of oil is used for refilling or adding to the system.
	Cold weather	Run hydraulic system until unit is warm to the touch and noise disappears.
II. Hydraulic transmission overheating	Heat exchanger not functioning	Locate trouble and repair and replace.
	Cooling fan not operating	Repair.
	Cooling fins packed with accumulated debris	Remove material from between fins.
	Fluid level low	Add oil to operating level.
III. System not developing pressure	<ol style="list-style-type: none"> 1. Sheared shaft key 2. Misadjusted or broken control linkage 3. Disconnected or broken drive mechanisms 	Locate and repair.
IV. Loss of fluid	<ol style="list-style-type: none"> 1. Ruptured hydraulic lines 2. Loose fittings 3. Leaking gaskets or seals in hydrostatic transmission 	<ol style="list-style-type: none"> 1. Check all external connections, tubing, and hoses. Tighten connections, replace ruptured tube or hose. 2. Observe mating sections of hydrostatic transmission for leaks. Replace seals or gaskets if possible.

INDEX

POWER TRAIN

BEVEL GEAR	E-1
DIFFERENTIAL	E-2
3 SPEED TRANSMISSION REMOVAL	E-3
3 SPEED TRANSMISSION DISASSEMBLY	E-6
3 SPEED TRANSMISSION ASSEMBLY	E-11
3 SPEED TRANSMISSION INSTALLATION	E-14
HYDROSTATIC TRANSMISSION	E-17
B-207 & B-208 TRANSAXLE	E-18
B-206 TRACTOR	E-19
TWO SPEED PULLEY	E-40
VARIABLE SPEED PULLEY	E-45

E



THIS PAGE INTENTIONALLY BLANK

BEVEL GEAR
All Models

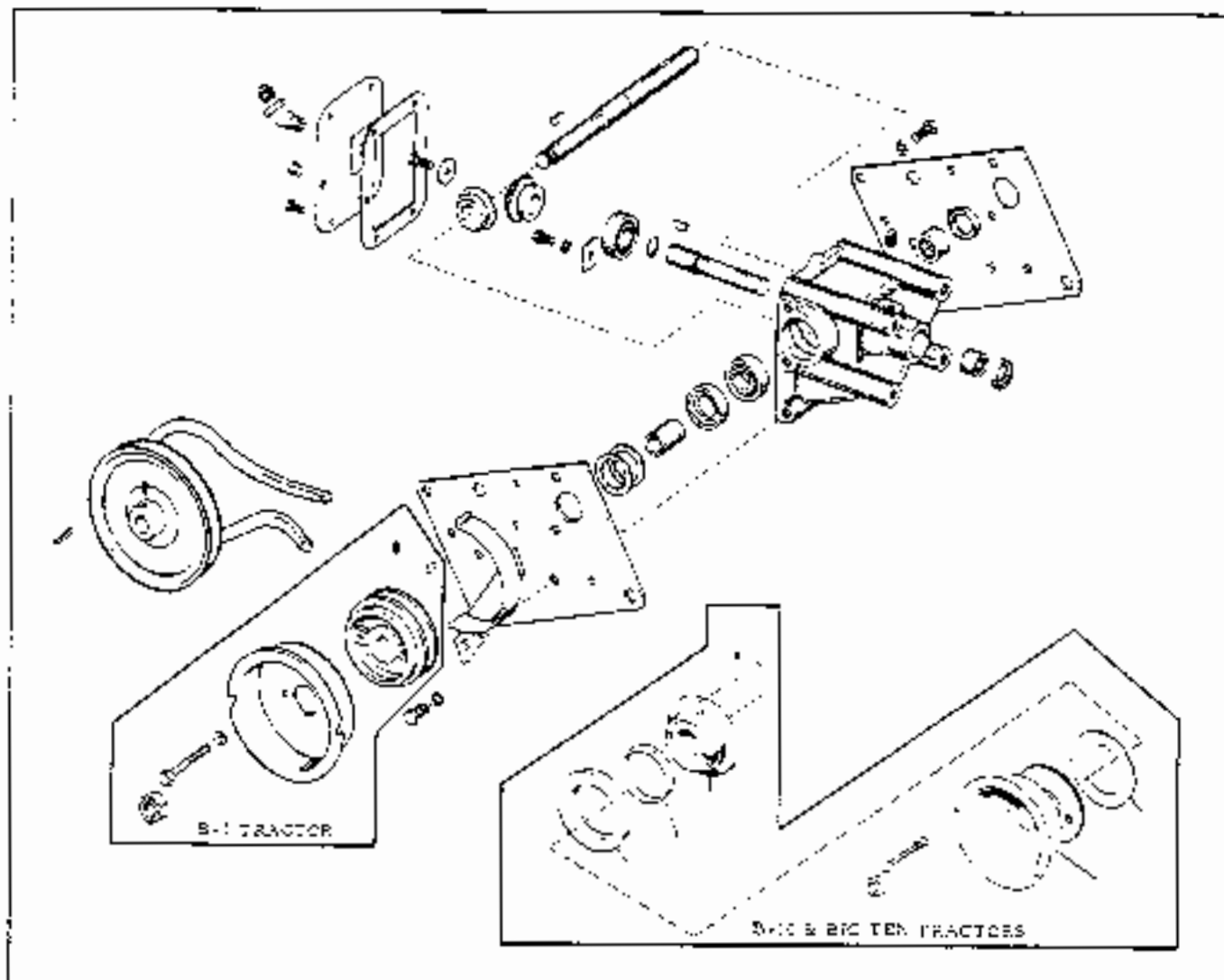

- | | |
|---|---|
| <ol style="list-style-type: none"> 1. Remove seat assembly. 2. Remove dash assembly. 3. Remove top frame cover. 4. Support tractor under frame just ahead of bevel gear housing. 5. Disconnect brake linkage, clutch-brake rod and transmission shift rod. 6. Remove transmission drive belt and cap screws securing transmission to side plates. Roll transmission rearward from tractor. 7. Disconnect drive shaft. 8. Remove gear shaft flange from bevel gear shaft. 9. Remove cap screws holding bevel gear housing to frame, lift off housing. 10. Remove rope starter pulley. 11. Remove transmission drive pulley. | <ol style="list-style-type: none"> 12. Remove P, T, O, drive pulley. 13. Remove side plates and rear cover. 14. Back up the driven bevel gear and carefully drive the driven shaft to the left until the key is free of gear. 15. Remove key and drive shaft out left side of housing. 16. Remove bearing clamp plate. 17. Drive front shaft, bearing and bevel gear assembly out of housing. 18. Remove bevel gear retaining cap screw and washer. 19. Remove bevel gear and bearing from shaft. 20. Inspect bearings and seal, renew if necessary. |
|---|---|

Installation is reverse of removal.

DIFFERENTIAL
All Models

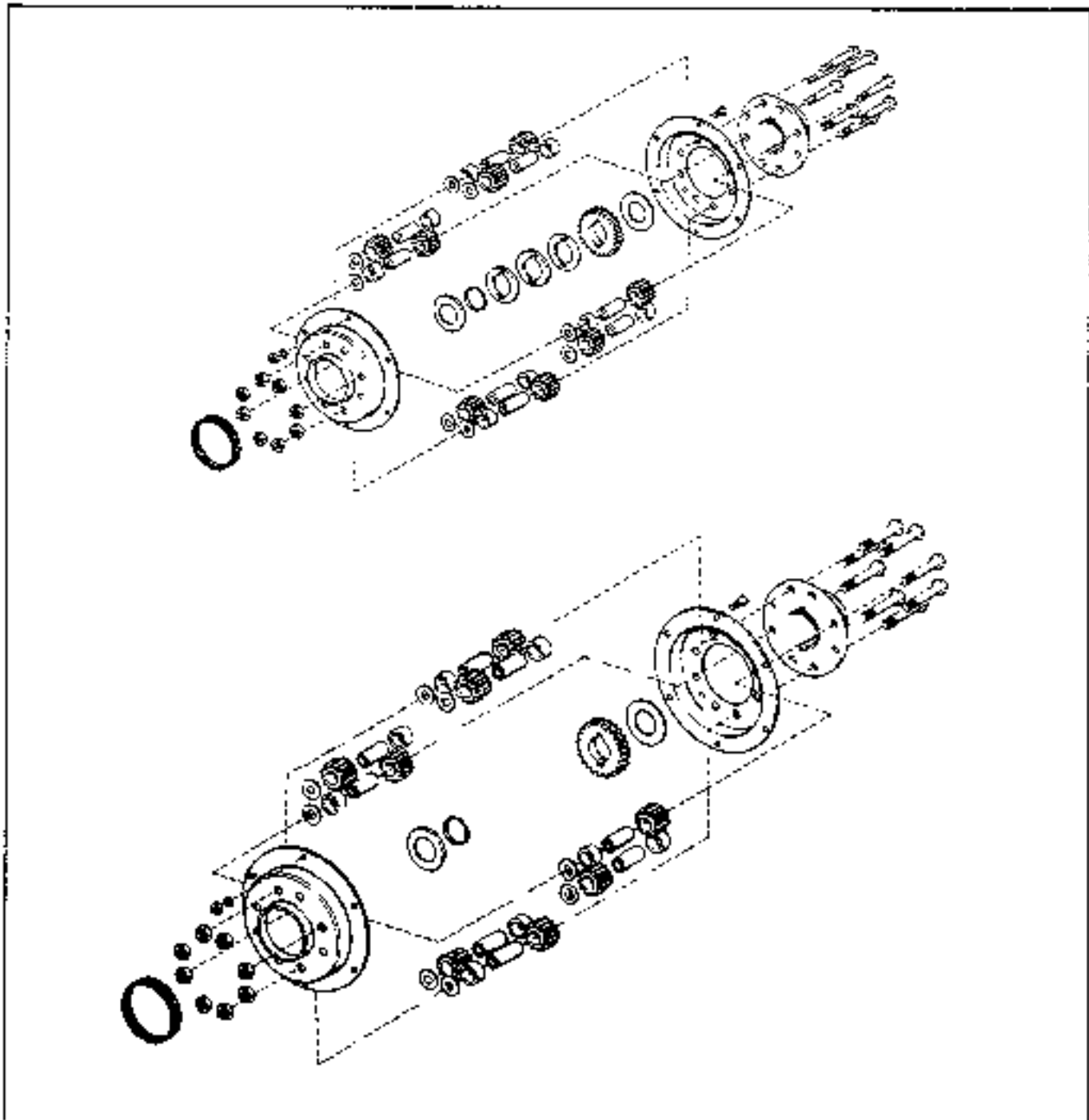

REMOVAL

1. Block up tractor and remove wheels.
2. Remove left wheel hub and key.
3. Loosen setscrews and remove collar and washers on left side of transmission.
4. Remove right hub, differential and axle assembly.
5. Remove set collar from right end of axle shaft.
6. Remove bolts from outer edge of case.
7. Remove nuts from inner row of capscrews.
8. Separate case halves. Leave capscrews in position to hold parts in place.
9. When removing parts identify to aid in re-assembly.
10. Reference to above illustration will aid in disassembly and assembly.
11. When installing the assembled differential, the axle and differential are properly seated so the seal between them is compressed. The axle is held in place by the collar on the left side of the transmission.

Tractors

SERVICE INFORMATION
Removal of the B-Series Transmission

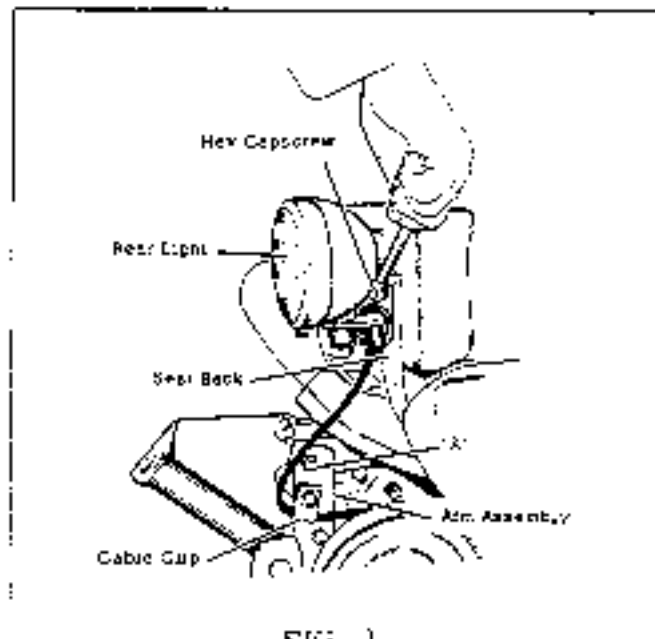

FIG. 1

NOTE: Before attempting removal of the transmission from the tractor, place the tractor on a level surface and drain all of the lubricating oil from the transmission. For fastest draining, remove the upper pipe plug from the transmission cover to allow air to enter transmission case.

To remove the transmission from the tractor, follow the sequence of steps as outlined below:

1. It is necessary to lift or jack up the tractor to a point where the rear wheels will be free of the ground. Place a support (strong enough to bear the weight of tractor) at a point under the frame and ahead of P, T, O, assembly.
2. If the tractor is equipped with a rear light, raise the tractor hood and disconnect the ground cable from the negative terminal of the battery.

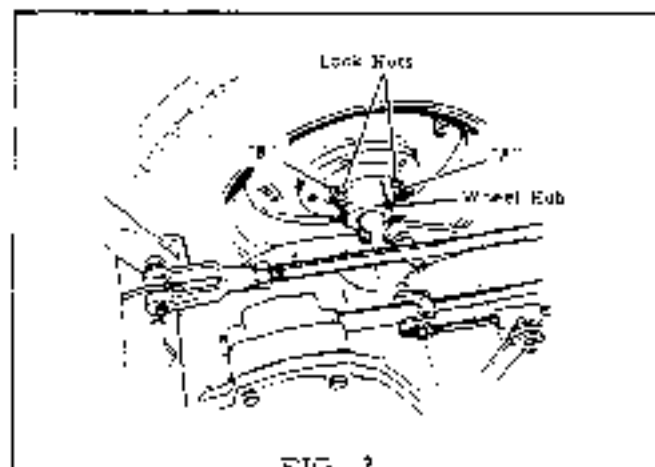

FIG. 2

Depending upon the style of battery, the negative terminal of the battery will be either on the R.H. or L.H. side of the tractor.

3. Remove the rear light from the tractor seat back by removing the hex capscrew holding the light mounting bracket to the seat back. Remove the cable clip from the R, W, arm assembly as shown in Fig. 1. This clip is held in place by a hex capscrew, flat washer, lockwasher and hex nut.
4. Remove the hex capscrew and lock nut from each arm assembly at point "A" as shown in Fig. 1. The seat assembly may now be lifted free of the tractor.
5. To remove the left rear wheel and hub complete; loosen the locknuts and setscrews "A" and "B" shown in Fig. 2. Setscrew "A" locks against the key located in the axle shaft and setscrew "B" locks into a hole in the axle shaft. It will be necessary to loosen "B" until the screw is free of the hole in the axle shaft. If necessary, tap the edge of the wheel hub with a lead mallet to loosen from the axle shaft.

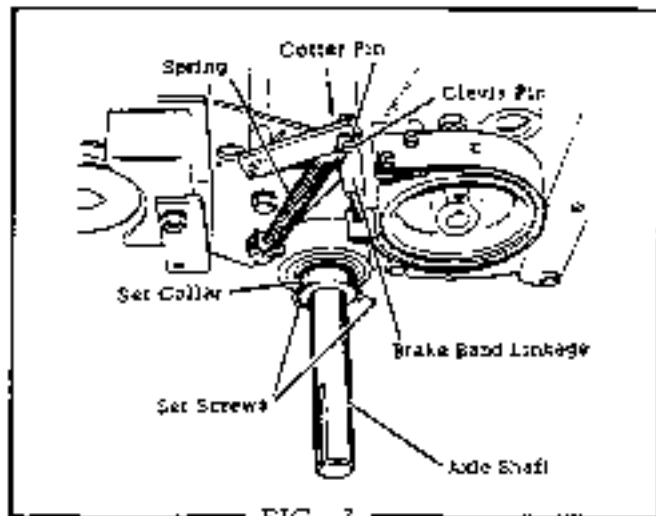

FIG. 3

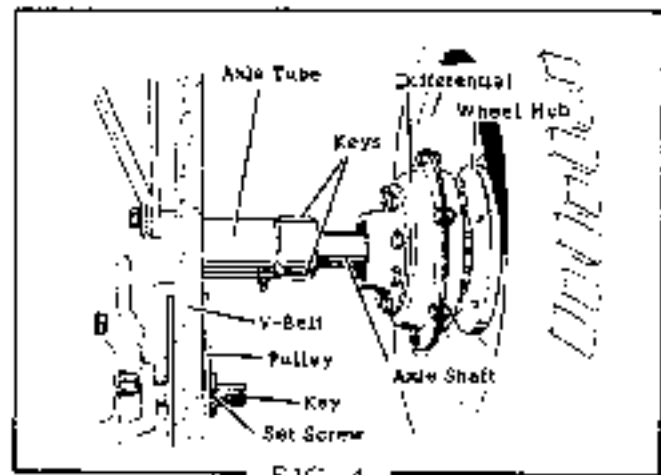

FIG. 4

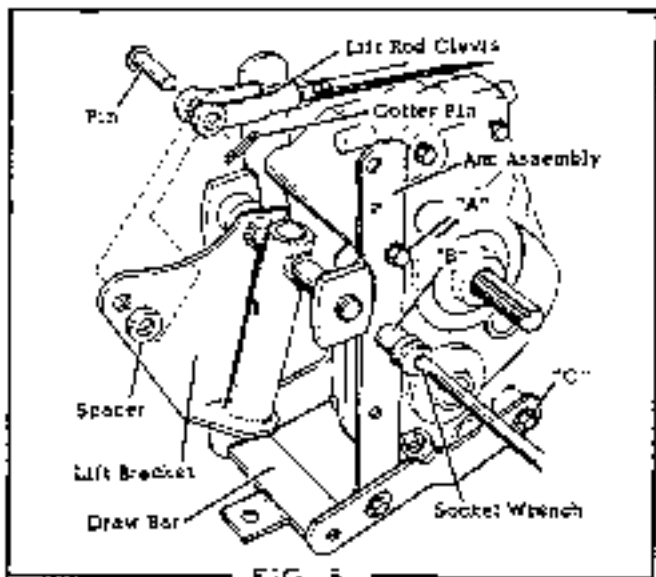

FIG. 5

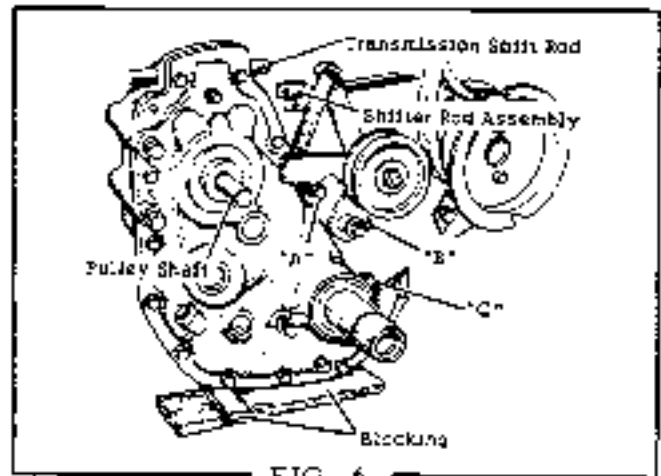

FIG. 6

6. Loosen the 2 setscrews holding the set collar on the axle shaft, as shown in Fig. 3, and remove the collar. Should the collar stick or bind on the paint on the axle shaft, remove the paint and sandpaper shaft. After the collar is removed, clean the axle shaft of any remaining paint and remove any burrs from edge of key-way or setscrew lock points by using a fine file. Burrs or paint, etc., will damage bearings when the axle shaft is removed, so be certain the axle shaft is smooth and clean.
7. From the right hand side of the tractor, remove the axle shaft, right hand wheel hub and differential in one piece by tapping the edge of the differential hub with a lead mallet. When the differential hub is free of the 2 keys on the transmission axle tube as shown in Fig. 4, pull the axle shaft, etc., straight out of the transmission.

8. Remove the V-Belt and pulley from the transmission pulley shaft, taking care not to use excessive thrust force on shaft. Use a wheel puller if necessary. The pulley is held in place by a setscrew and key. Do not hammer or the snap rings on the shaft inside transmission may be damaged.
9. Dis-connect the lift rod clevis from the rear lift bracket by removing the cotter pin, spacer, and pin as shown in Fig. 5. Remove hex capscrews "A", "B", and "C" from both sides of the arm assembly and lift off the drawbar, rear lift bracket, and arm assembly as one piece.
10. Dis-connect the shifter rod assembly from the transmission shift rod as shown in Fig. 6.

Dis-connect the brake band linkage as shown in Fig. 3, by removing the cotter pin and clevis pin and spring.

Add blocking to support the weight of the transmission at points shown in Fig. 6.

Remove the hex capscrews "A", "B", & "C" from the left hand side of the transmission and "A" & "B" from the right hand side. Now loosen "C" on the right hand side and steady the transmission by gripping the pulley shaft with one hand while removing "C" with the other hand.

NOTE: Before starting to dis-assemble the transmission, it will be necessary to remove the brake band and linkage as shown in Fig. 7. To do this, remove the 2 hex capscrews, lockwashers, and hex nuts. Remove the brake drum by loosening the setscrew, and pull the drum from the shaft with a wheel puller as shown. Do not hammer on the snap rings on the shaft inside the transmission may be damaged.

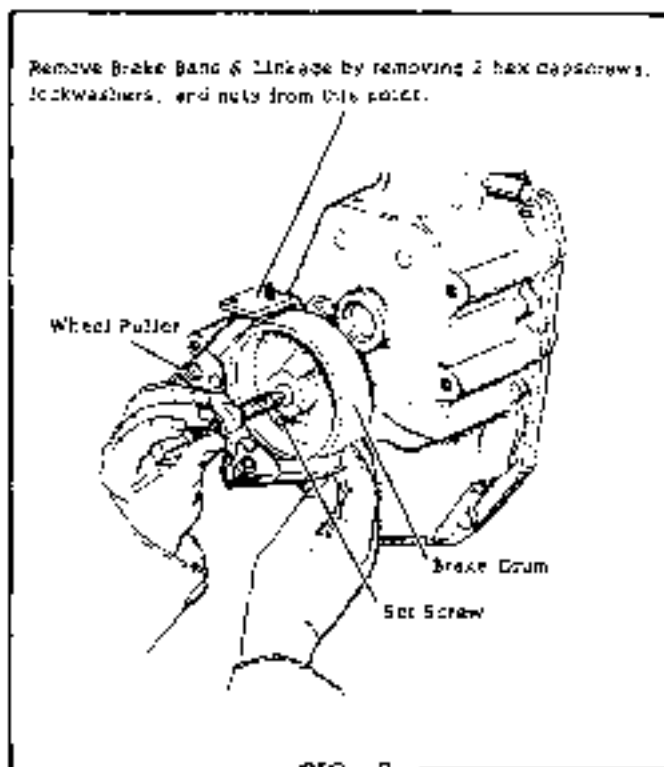

DISASSEMBLY OF THE B SERIES TRANSMISSION

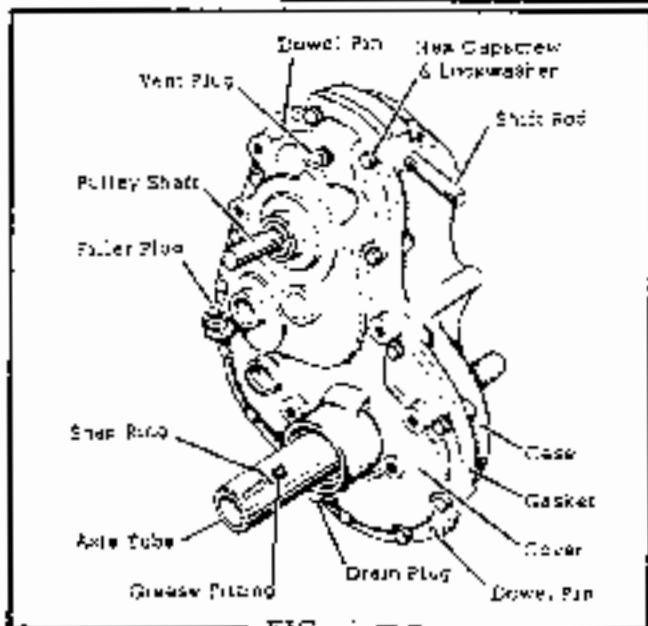

FIG. 1

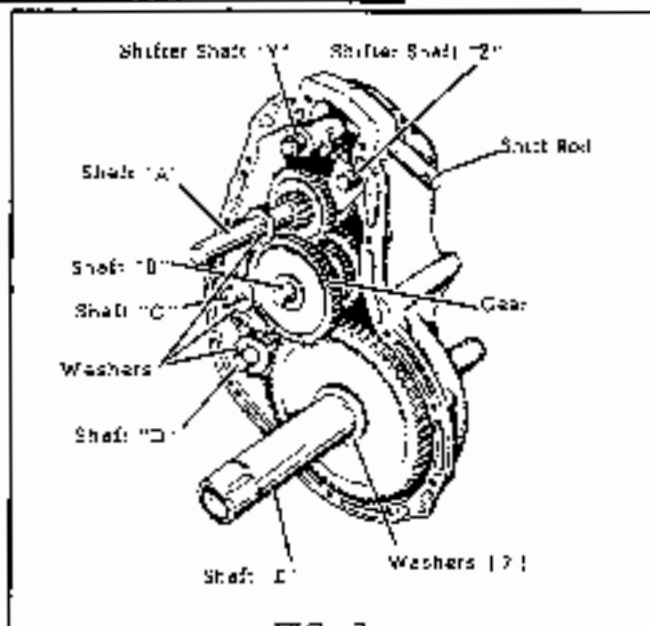

FIG. 2

Before beginning to dis-assemble the transmission be certain to file on the edges of the key-way on the brake drum shaft to avoid cutting the oil seal if any burrs have been raised there. Remove the 2 keys from the axle tube and check for burrs. File if necessary. Remove the grease fitting from the axle tube, and also the snap ring. Check for burrs. Check the drive pulley shaft for burrs and file if necessary.

After having made sure that the axle tube, brake drum shaft, and drive pulley shaft are free of burrs or sharp protrusions that might cut or damage the oil seals during dis-assembly, proceed by following the steps outlined below.

1. Remove the oil drain plug and allow any remaining oil to drain from the transmission. Draining will be speeded by removing the upper pipe plug from the transmission case, and setting the transmission in an upright position as if in place on the tractor.
2. Remove the 14 hex head capcrews and lockwashers from around the edge of the transmission cover. Drive the 2 dowel pins down into the transmission case holes and insert a screw driver at several points between the cover and the case and pry upwards to break the cover loose from the case. See Fig. 1. When cover is free, lift off.

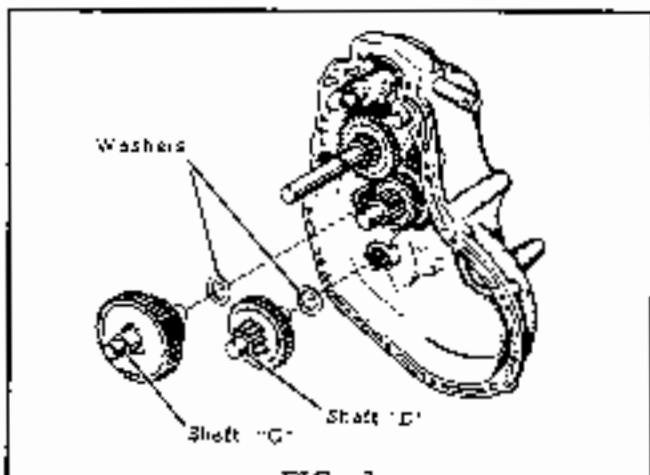

FIG. 3

3. Remove the flat washer from shaft "A", shaft "C", and shaft "D". Now remove the gear from the end of shaft "B". Remove the axle tube and gear assembly "E" from the transmission case. See Fig. 2.
4. Lift out shaft "C" with gear assembly and then remove shaft "D" with its gear assembly. See Fig. 3.

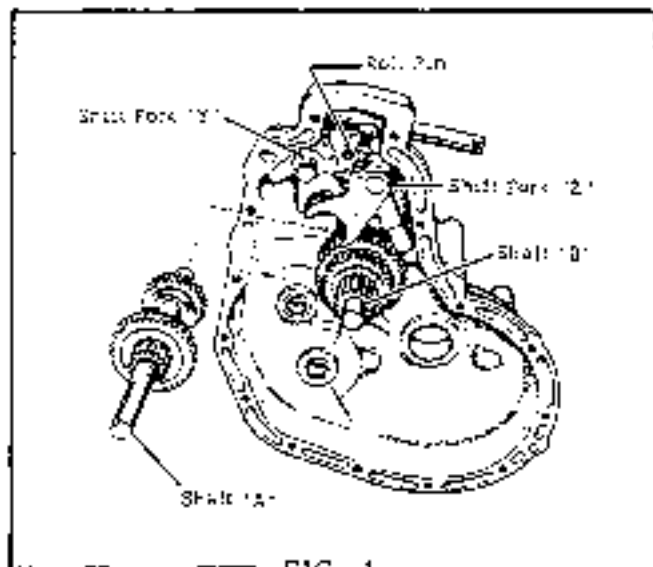

FIG. 4

5. To remove the pulley shaft "A" and its gear assembly it will be necessary to position the shift forks as follows:

- A. Place shift fork "Y" in Neutral so that the lower edge of shift stem slot is even with the end of roll pin in the transmission case.
- B. Place the shift fork "Z" in top-most position. **CAUTION:** do not raise too far, or it may come off of the shaft and the lock ball or spring may be lost.

Now, lift the pulley shaft "A" with one hand to clear the lower bearing, and with the other hand, raise the cluster of gears on shaft "B" slightly to allow pulley shaft "A" and its gears to be moved away from the shift forks. When the yokes of the shift forks disengage from the shift rings on the gear clusters on shaft "A", the shaft and gears may be lifted free of the transmission. Now, lift out shaft "B" and its gear. See Fig. 4.

6. The reverse gear "F" may be removed now, by undoing the lock nut on the back-side of the transmission case, and removing the hex head capscrew from the bracket on the inside of the case. (See Fig. 5).
7. Remove the shifter forks and shafts from the transmission case by loosening the setscrews

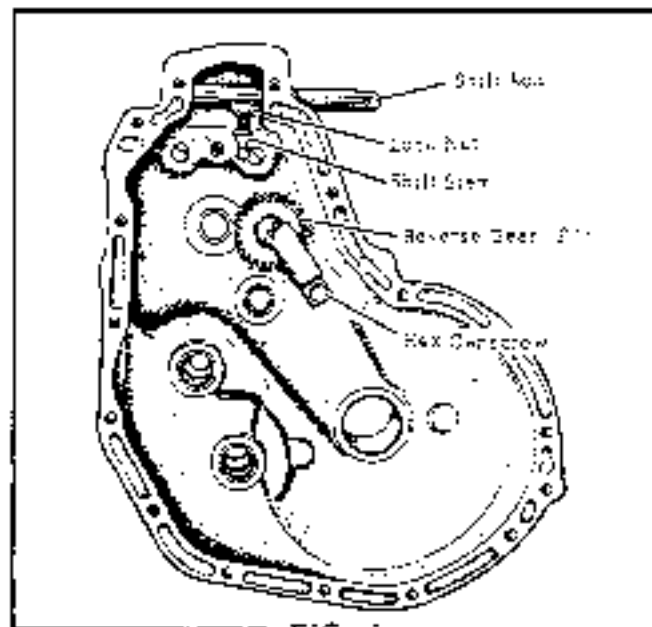

FIG. 5

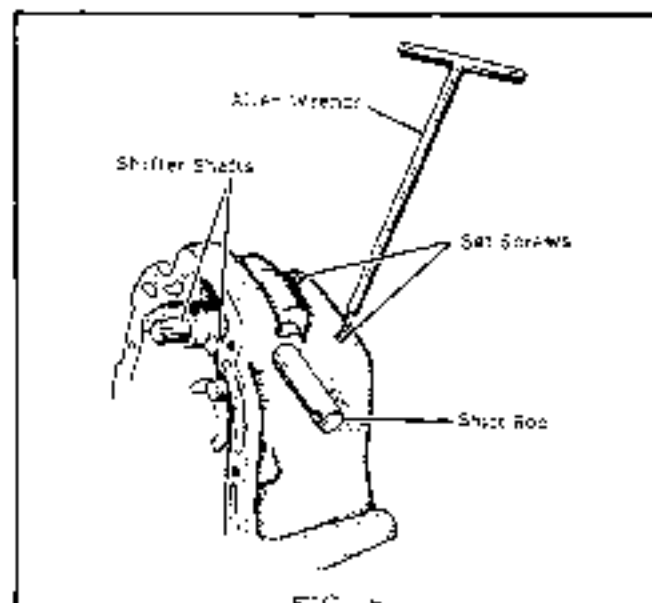

FIG. 6

located as shown in Fig. 6. Loosen these screws sufficiently to clear the locating holes in the shafts.

8. To remove the shift rod first loosen the lock nut on the shift stem, and unscrew the shift stem from the shift rod. The shift rod may then be pulled from the case. See Fig. 4.

SHIFTER FORKS FOR THE B SERIES TRANSMISSION

NOTE: Before attempting any dis-assembly or assembly of shifter forks, it should be understood that they are to be removed from the transmission case by following the sequence of steps completely as outlined in the transmission dis-assembly procedure.

Dis-Assembly

1. To remove the shifter forks from the shifter shafts, slide the fork towards the end of the shaft without the retaining ring. Cup one hand over the lock ball loading hole while withdrawing the shaft to prevent the loss of the shift lock ball or spring.

The lock ball and spring are under tension when the fork is in place on the shaft, and unless care is taken the ball may fly out as the shaft is removed and be lost.

Assembly

The shifter shafts are of unequal length and the position of the fork is reversed from one shaft to the other. To properly assemble the shafts and forks, proceed as follows:

1. Identify the long shaft, (it has a retaining ring on the end of the shaft farthest from the setscrew hole) and insert the setscrew hole end into the hub of a shift fork. See Fig. 1. Before pushing the shaft through the hub of fork, insert the shift lock spring and ball through the loading hole and depress with a $3/8"$ rod so that the shaft may slide through.

Identify the short shaft, (it has a retaining ring located near the setscrew hole) and insert the end without the retaining ring into the hub of the shifter fork. Before pushing the shaft through the hub of the fork, insert the shift lock spring and ball through the loading hole and depress with a $3/8"$ rod so that the shaft may slide through. See Fig. 1.

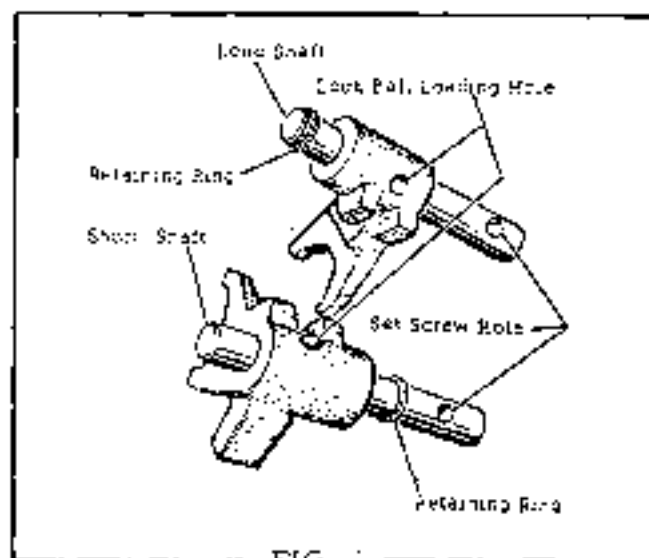

FIG. 1

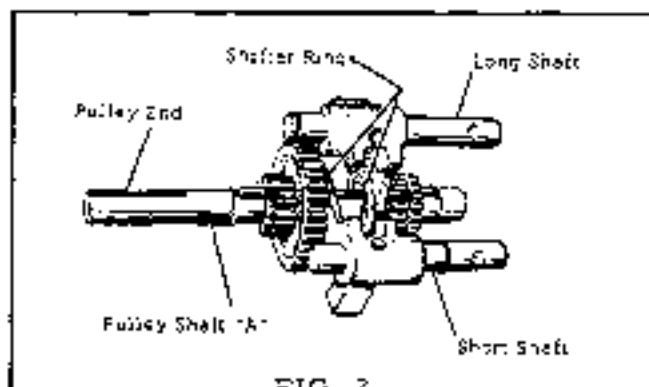

FIG. 2

To obtain a clear idea of the position of the shift forks when properly installed on the shifter shafts, refer to Fig. 2. This shows the general appearance of the shift forks and shafts and the shift rings that the forks engage. In this particular view, the parts are shown in their relative positions as they would be seen if the end of the transmission were to be cut off. Note that the gear cluster nearest the pulley end of the shaft is engaged by the shift fork on the short shaft, and the other gear cluster is engaged by the shift fork on the long shaft. Also note the relative position of the shift forks to each other.

BEARINGS FOR THE B SERIES TRANSMISSION

The Transmission contains a total of 12 bearings. 4 needle bearings and 1 bronze bearing are located in the transmission case, 4 needle bearings and 1 bronze bearing are located in the transmission cover and 2 bronze bearings are located in the axle tube.

TRANSMISSION CASE

<u>Location</u>	<u>Description</u>
"A"	Needle Brg., sealed on one end
"B"	Needle Brg., open on both ends
"C"	Needle Brg., sealed on one end
"D"	Needle Brg., sealed on one end
"E"	Bronze Brg.

TRANSMISSION COVER

<u>Location</u>	<u>Description</u>
"A"	Needle Brg., open on both ends
"B"	Needle Brg., sealed on one end
"C"	Needle Brg., sealed on one end
"D"	Needle Brg., sealed on one end
"E"	Bronze Brg.,

AXLE TUBE

<u>Location</u>	<u>Description</u>
Each end of tube	Bronze

REMOVAL

To remove the bearings, disassemble the transmission as outlined in transmission disassembly instructions. For best results, use a rod slightly smaller than the outside diameter of the bearing and press the bearing from its housing. Use caution to avoid damaging the bearing housing.

INSTALLATION

NEEDLE BEARINGS

Be sure to use the correct size bearing for each location as listed in the chart above. Press bearings "A", "C", & "D" into the cover and case until the end of the bearing case is flush with the machined face of the bearing housing. This machined face of bearing housing is on inside of transmission. Bearing "B" is to be installed 1/16" below surface of bearing housing.

NOTE: The needle bearings all have a number stamped on one end of bearing case. This is the end of bearing to press against, when installing. **DO NOT** press against the un-numbered end of the bearing or damage may result.

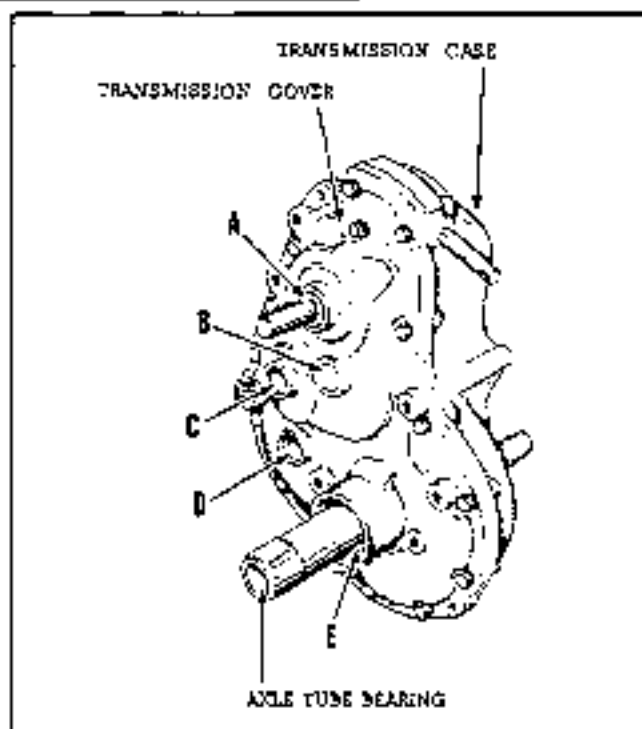

The bearings with the sealed end, are to be installed with the sealed end facing the outside of the transmission.

BRONZE BEARINGS

Press one bronze bearing into the "E" bearing housing of the transmission case until it is flush with the inside machined face of bearing housing. Now insert the axle tube into the bearing and place the transmission cover over the dowel pins of case and slide the other bronze bearing into place in the housing of the cover. Press the bearing into the housing until the outer end of bearing is flush with bottom face of the smaller of two counter-bores in housing.

NOTE: The axle tube acts as an aligning mandrel for the bearings, and must be used to prevent cocking the bearings when they are being installed.

AXLE TUBE

Press a bronze bearing into one end of the tube until it is flush with the end of the tube. Now insert the axle shaft through the axle tube and slide the other bronze bearing over the axle tube until it starts to enter the opposite end of axle tube. Press the bearing into position flush with the end of axle tube.

NOTE: The axle shaft acts as an aligning mandrel for the bearings and must be used to prevent cocking the bearings when they are being installed.

OIL SEALS FOR THE B SERIES TRANSMISSION

The Transmission contains a total of 4 oil seals; 2 seals are in the transmission cover, and 2 seals are in the transmission case. See Fig. 1 and order the proper seals for replacement.

Transmission Cover

- (A) One Seal for Pulley Shaft
- (B) One Seal for Axle Tube

Transmission Case

- (C) One Seal for Brake Drum Shaft
- (D) One Seal for Axle Tube

REMOVAL

To remove old seals, carefully pry the seals out of their positions in the case and cover.

Use caution to avoid damage to either the bearings or the cast iron seats or bores that the seals rest in.

DO NOT ATTEMPT TO RE-USE OR SALVAGE SEALS. When seals are removed from their positions in the transmission, they are not fit for re-use, and must be discarded.

INSTALLATION

The importance of properly installing oil seals cannot be minimized if they are expected to do their job and do it well.

Failure to observe correct installation procedure will account for more seal failure than any other cause.

Inspect the surface of each shaft to be certain that no nicks, burrs, scratches, or sharp edges will be able to damage the seals during installation. Be particularly critical of the area of the shaft that the seal covers when in position. If a shaft shows any nicks, scratches, or burrs at this area, **DISCARD THE SHAFT** and replace with a new one. Any attempt to file or remove flaws at this point will only result in a flat spot and oil leakage.

1. Make sure that the seal is correct size. See Fig. 1, for correct location.
2. Check the cast iron seat or bore that the seal will rest in. Remove all nicks, burrs, scratches, or foreign material.
3. When installing the seal, it is advisable to use a thimble that will fit over the shaft as shown in Fig. 2. This will aid in stretching the spring element in the seal to allow it to slide over the shaft, and at the same time will protect the seal from damage or cutting by the edges of key-ways. **NOTE:** The thimble should be long enough to protect the

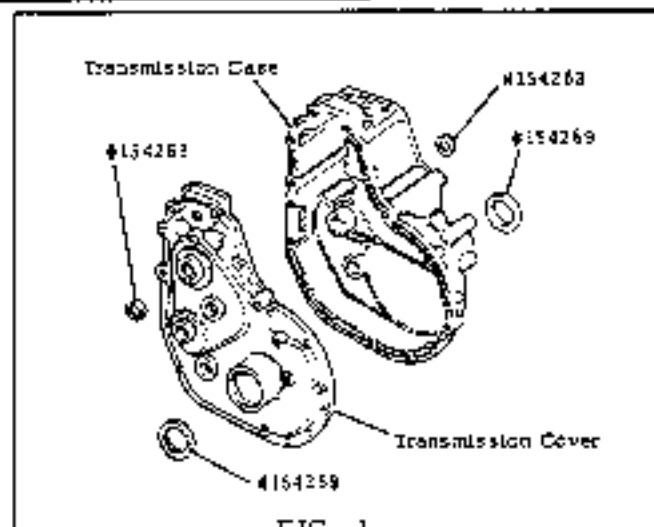

FIG. 1

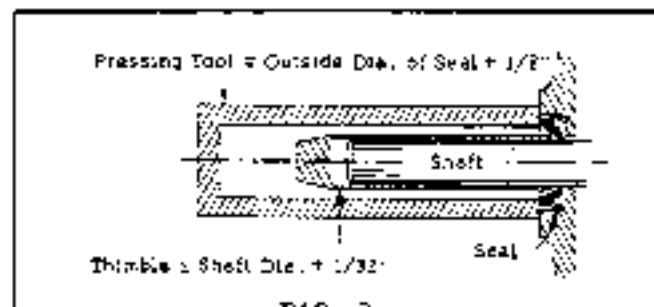

FIG. 2

seal until it is completely past all holes or key-ways. The maximum diameter of the thimble should equal the shaft diameter plus 1/32". Lubricate the surface of the thimble with clean grease to aid in sliding the seal in place.

If a thimble is unavailable, wrap the shaft with a heavy grade of paper lubricated with oil or grease. When wrapping the shaft, start at the seal end of the shaft and wrap in an overlapping spiral fashion, being sure to cover the key-ways.

4. Remove the seal from its wrapper or package, and gently lubricate the sealing element with a light coating of absolutely clean grease. Do not run your finger roughly around the sealing element, as it is easily deformed and ruined.
5. As these seals are to be installed flush with the outer surface of the bore or seat, use a pressing tool at least 1/8" larger in diameter than the outside diameter of seal as shown in Fig. 2. Place the seal on the thimble with the spring element of the seal facing the liquid to be retained, and with the pressing tool, gently slide the seal towards its seat. Avoid cocking the seal as it starts into its seat, and gently tap the pressing tool with a hammer until the seal is in place. **NEVER HAMMER ON THE SEAL ITSELF.**

ASSEMBLY OF THE B SERIES TRANSMISSION

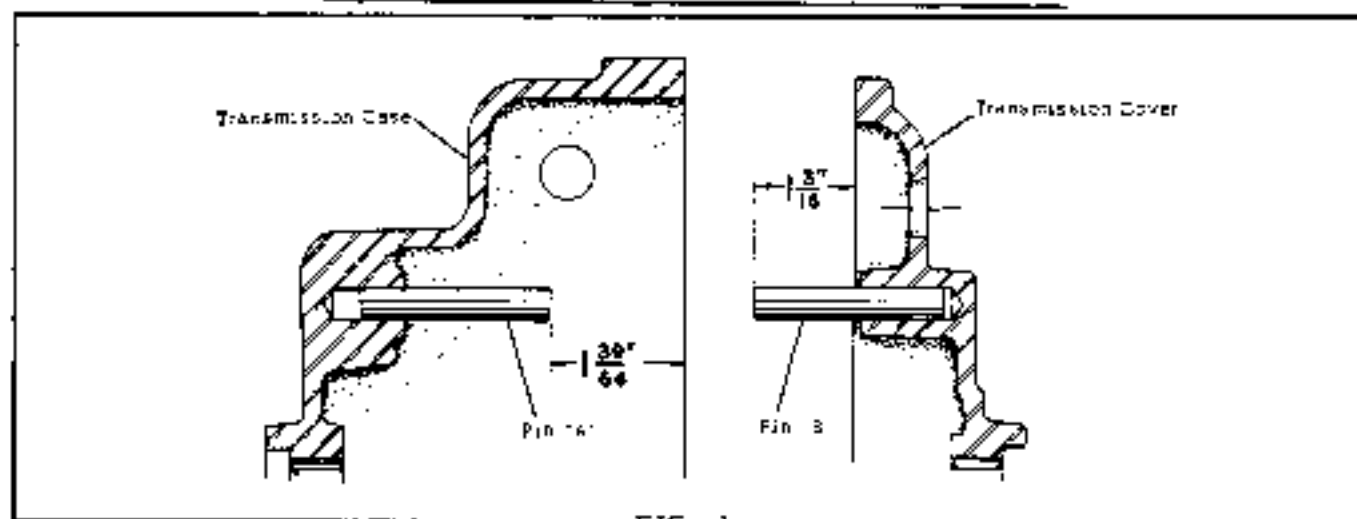

FIG. 1

Before beginning to assemble the transmission, make certain that the transmission case, cover, and all of the parts that go into the transmission have all been completely cleaned. Scrape the mating surfaces of the case and cover to remove any pieces of gasket material that may have stuck. As you put the various gear shafts into their bearings, apply a light coating of clean transmission oil to the bearing surfaces of each shaft.

To proceed with the transmission assembly, follow the sequence of steps as outlined below:

1. Before beginning assembly, check the 2 roll pins that limit the movement of the shift stem. See Fig. 1. It is imperative that both of these pins be checked for proper height and adjusted if necessary. Note the dimensions shown: pin "A" in the transmission case is set to give a dimension of $1\text{-}39/64$ " from the end of the pin to the face of transmission case, and pin "B" in the transmission cover is set to give a dimension of $1\text{-}3/16$ " from the end of the pin to the face of cover. When replacing pins, the groove of the pin should face the top of the transmission case.
2. Insert the shift rod into the transmission case and position it to allow the shift stem

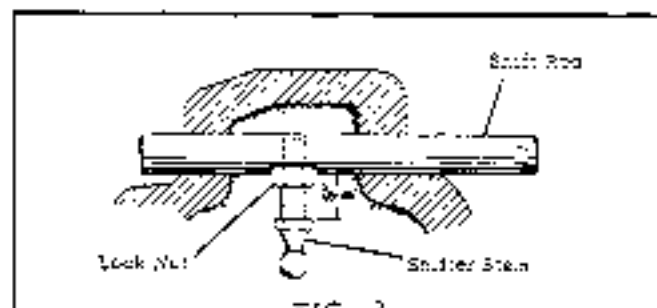

FIG. 2

with lock nut to be screwed into the shift rod as shown in Fig. 2.

Screw the shift stem into the shift rod until a distance of $5/8$ " from the round surface of the rod to the shoulder of shift stem is obtained, as shown in Fig. 2. This setting is important to insure proper shifting, so check and adjust until correct. Be sure the lock nut is tight enough to hold the shifter stem at this setting.

3. Assemble the shifter fork assembly with the longer shaft into the "Y" shaft hole of the transmission. Take care to be sure that the setscrew, which holds the shaft in place, is actually locked into the setscrew hole of the shifter shaft. Now assemble the shorter shaft into the "Z" shaft hole of the transmission and lock in place in same manner as other shifter fork assembly. See Fig. 3.

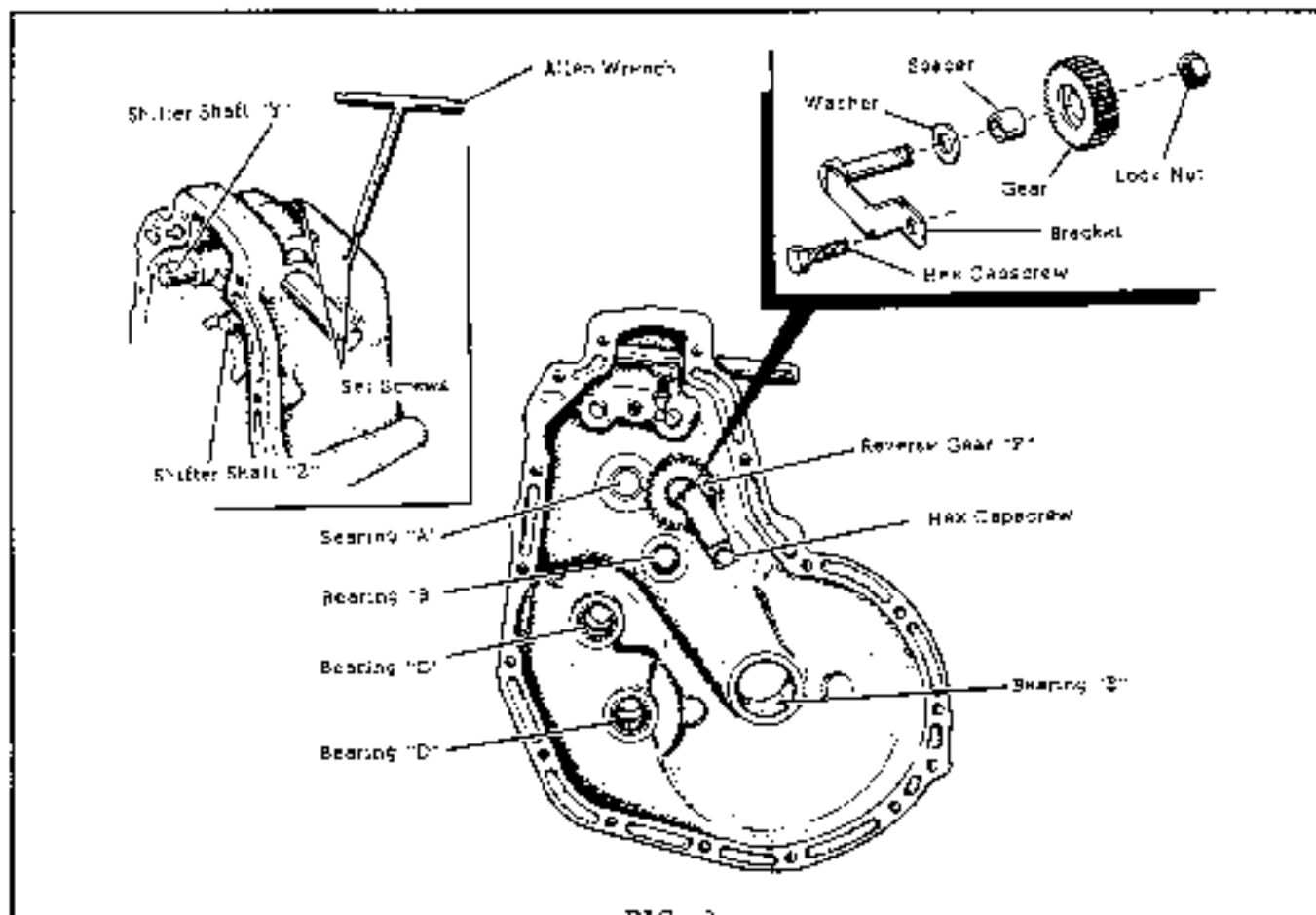

FIG. 3

4. Assemble the reverse gear "F" as shown in Fig. 3. When properly assembled, insert the gear assembly into the transmission case and position the bracket over the mounting hole in the case. See Fig. 3. Fasten the bracket to the case with a hex capscrew and tighten to 20 ft. lbs. $+0$ lbs. -3

Add a lock nut to the pin protruding through the transmission case and tighten to 35 ft. lbs. $+0$ lbs. -5

5. Place shaft "B" and gears into bearing "B" in the transmission case. See Fig. 4.
6. Place a greased flat washer over face of bearing "A" in transmission case. See Fig. 3 & 4. To install shaft "A" and gears, first move the "Y" shift fork into Neutral (See dis-assembly instructions) and move the "Z" fork into raised position (see dis-assembly instructions). Raise the gear cluster on shaft "B" slightly and move shaft "A" toward the shift forks. When you slide the shift rings on the gear assemblies into position against the shift forks, it should be possible to lower shaft "A" into place in its bearing.

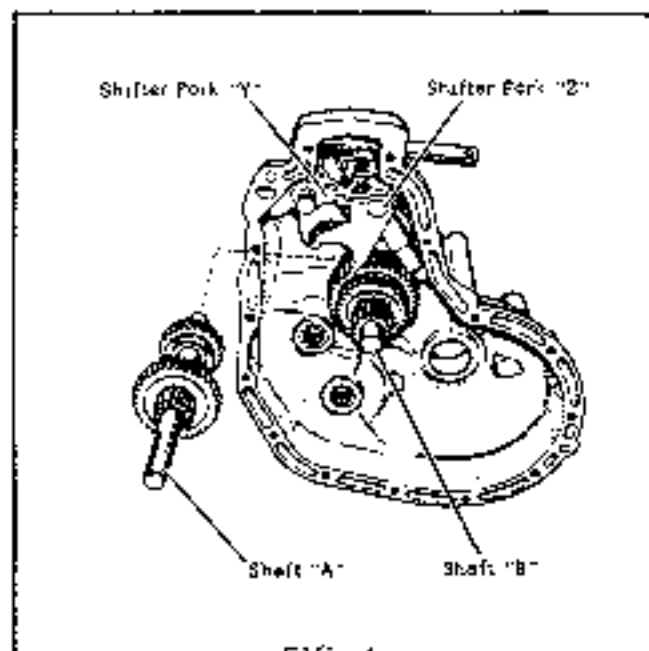

FIG. 4

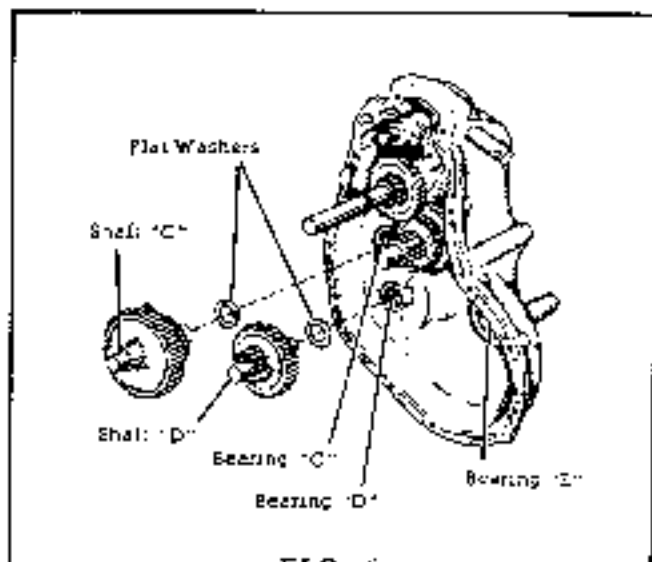

FIG. 5

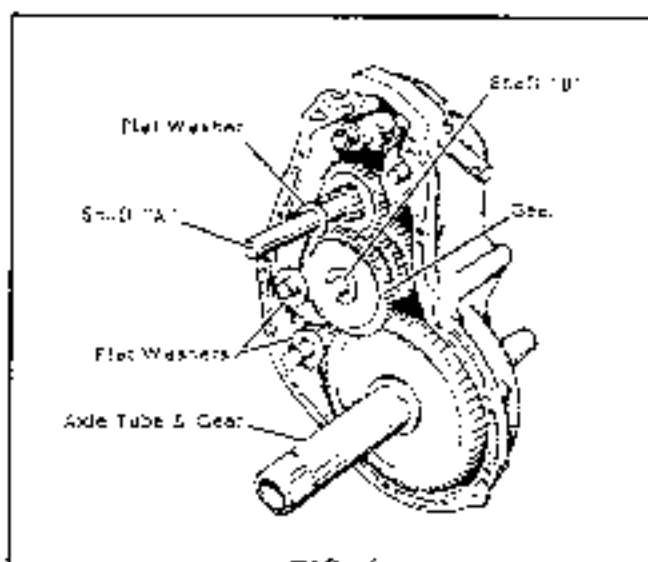

FIG. 6

7. Place a greased flat washer over face of bearing "D" and place shaft "D" and gears in place in the bearing. See Fig. 5.
8. Place a greased flat washer over face of bearing "C" and place shaft "C" and gears in place in the bearing. See Fig. 5.
9. Place 2 greased flat washers over face of bearing "E" and place axle tube and gear in place in the bearing. See Fig. 6.
10. Assemble the gear to end of shaft "B", with the beveled edge facing gear cluster on shaft "A". Place a greased flat washer on shaft "A" and on end of shaft "C" and shaft "D". Add 2 flat washers to axle tube. See Fig. 6.
11. Before putting gasket in position, drive the 2 dowel pins up until they protrude approximately $1/4"$ to $5/16"$ above the machined face of the transmission case. Now position the new gasket in place and seat the cover over the 2 dowel pins before inserting the capscrews. When cover seats properly, insert and tighten the capscrews.
12. Attach a pulley to the pulley shaft and rotate by hand to check gears for binding. Check all gear ranges to see that gears rotate freely. If a slight bind is noticed, tap the end of the pulley shaft and brake drum shaft with a raw-hide mallet. It may be that one

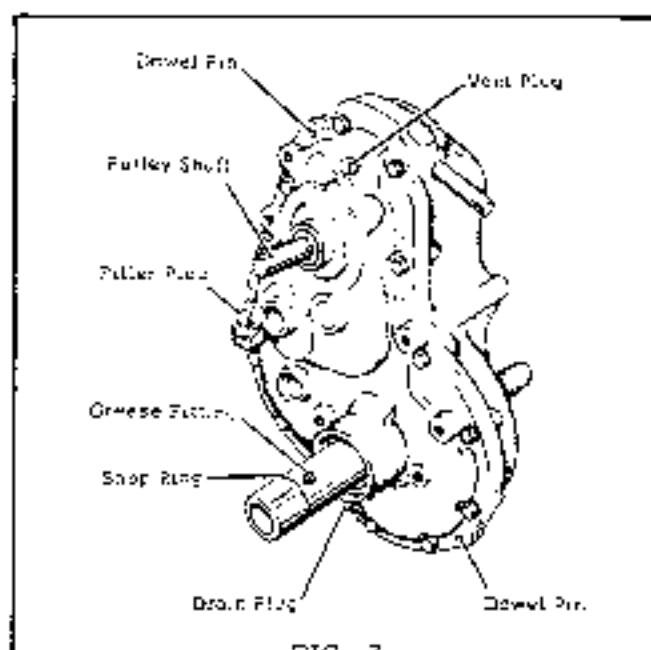

FIG. 7

of the bearings is not seated far enough into the cover or case, and the impact of the mallet will drive it into position and remove the binding. If a severe binding is noticed, it will be necessary to dis-assemble the transmission and locate the cause.

13. Assemble the grease fitting and snap ring to the axle tube as shown in Fig. 7.

INSTALLATION OF THE B SERIES TRANSMISSION

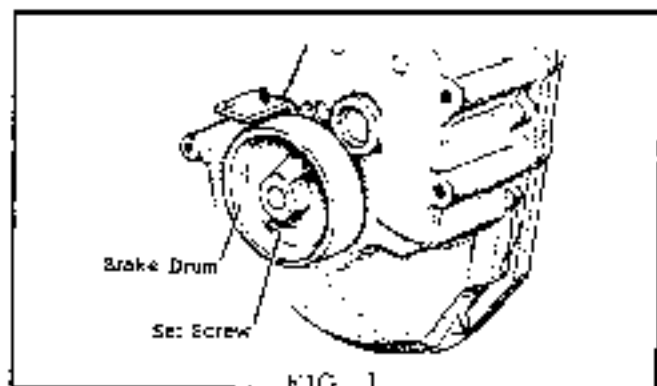

FIG. 1

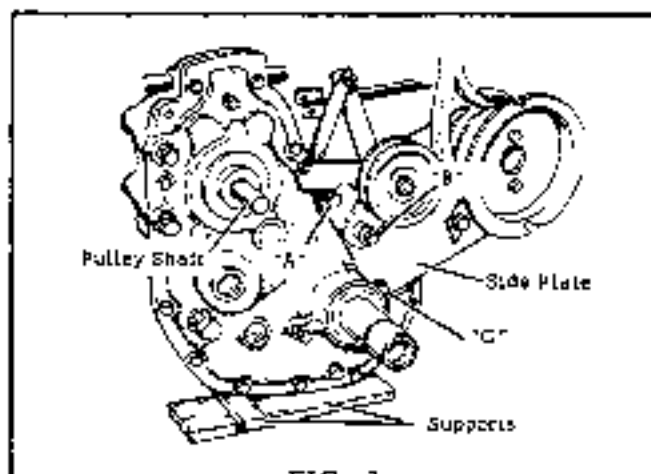

FIG. 2

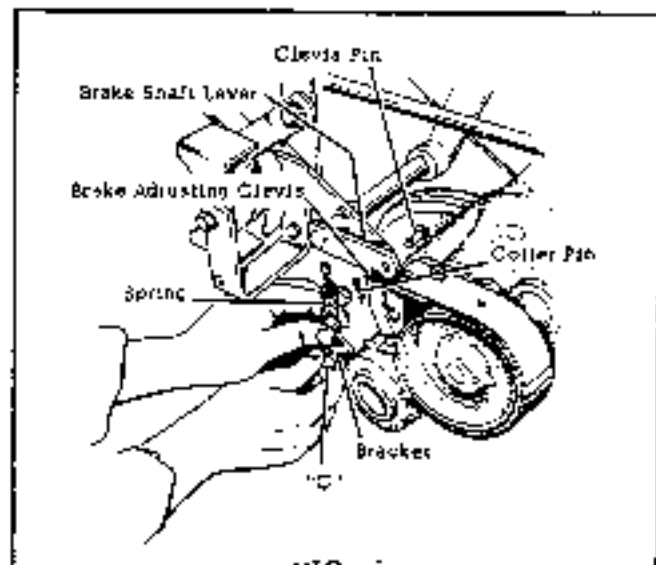

FIG. 3

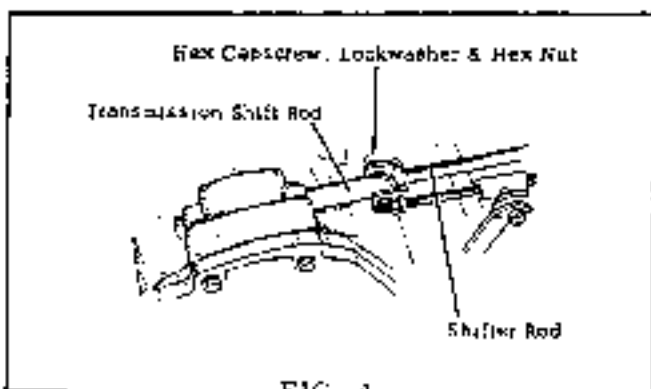

FIG. 4

To properly install the transmission to the tractor, follow the sequence of steps as outlined below:

1. Assemble the brake drum to the shaft with the key and setscrew. The setscrew side of the brake drum faces away from the transmission. See Fig. 1.

Add the brake band and adjusting linkage and secure in place with 2 hex cap screws, lockwashers, and hex nuts.

2. Position the transmission case on supports so that hole "C" on R.H. side of transmission lines up with the mounting hole of side plate. See Fig. 2. Insert the cap screw and tighten partially. Hold the pulley shaft with one hand and by using your knee for a brace, position

the transmission so that bolt "A" may be inserted and partially tightened. Add bolt "B". Now add bolts "A" & "B" to the L.H. side of the transmission. With the spring bracket in place on bolt "C" and positioned as shown in Fig. 3, tighten the bolt. Now tighten all 6 mounting bolts securely.

3. Insert the clevis pin through the hole of brake adjusting clevis, through the hole in lever of clutch and brake shaft assembly, and through the end loop of spring. After the pin is in place, secure with cotter pin. See Fig. 3.
4. Use "Vise-Grip" pliers and attach the large spring from the Power Take-Off to the mounting hole on the spring retainer.
5. Attach the clevis of the shifter rod to the transmission shift rod, using hex cap screw, lockwasher, and hex nut as shown in Fig. 4.

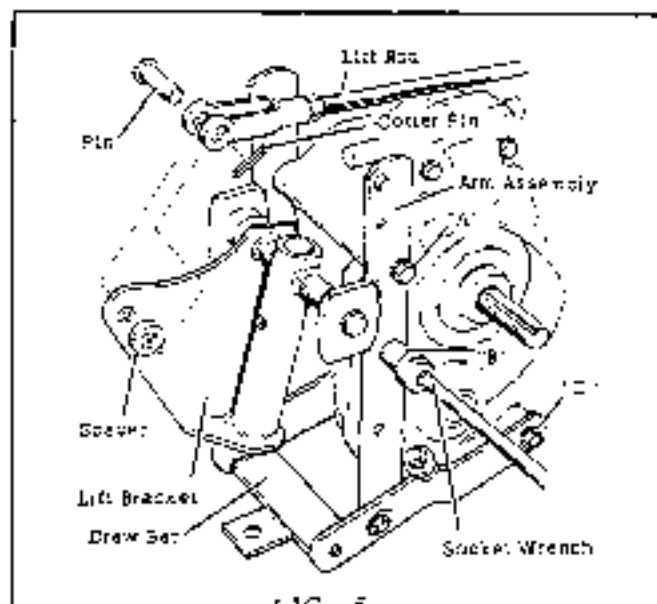

FIG. 5

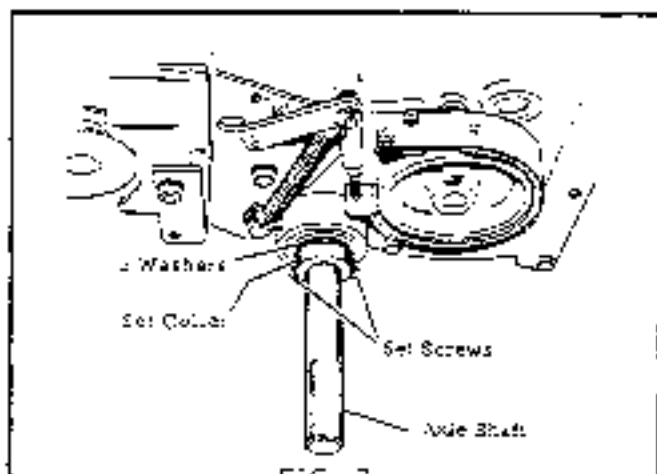

FIG. 7

- b. Mount the drawbar, rear lift bracket, and arm assembly to the transmission as shown in Fig. 5 and fasten with hex capscrews (3 on each side) "A", "B", & "C".

Connect the lift rod clevis to rear lift bracket with pin, spacer and cotter pin. The spacer is to be placed on R.H. side of the lift bracket.

7. Place the key in the key-way of pulley shaft and mount the pulley with the hub facing away from the transmission. Do not tighten the setscrew until after the V-belt is in place and the pulley is aligned with the pulley on the bevel gear box. See Fig. 6.
8. Insert the axle shaft into the axle tube on the R.H. side of the transmission and place the 2 keys in the slots on the axle tube. Align the key-ways in the differential hub with the keys and while holding the keys in place, push the

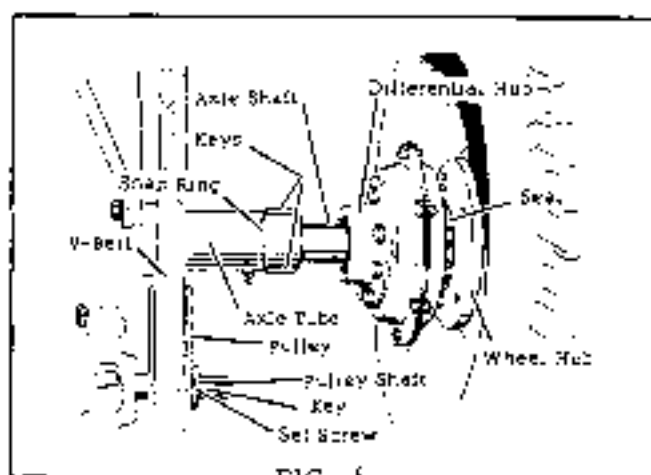

FIG. 6

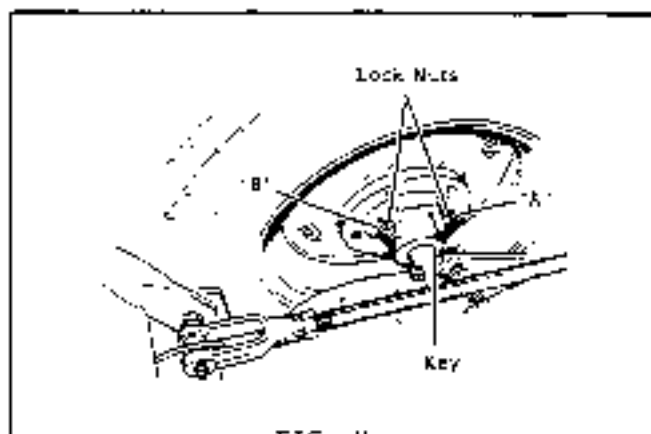

FIG. 8

axle shaft through the transmission. The differential hub is to seat against the snap ring on the axle tube. See Fig. 6.

9. Make sure that the axle and differential are properly seated so that the seal between the differential and the wheel hub is compressed. See Fig. 6. The axle is then held in this position by placing the set collar over the L.H. end of the axle shaft and locking it securely against the axle tube by means of the 2 setscrews. It is very important that this set collar be securely locked at all times to eliminate any end play of the axle shaft. See Fig. 7.

NOTE: Later production models have 3 washers between the set collar and the axle tube for the purpose of moving the set collar farther out on the axle shaft. Use washers No. 105050.

10. Place the key in the slot of the axle shaft and mount the L.H. wheel and hub in place over the key. Tighten the setscrew "B" into the setscrew hole on the axle shaft. See Fig. 8. Tighten the setscrew "A" and lock both setscrews with the lock nuts. Tighten securely.

11. Mount the seat assembly to the tractor, placing the arms of the seat pivot assembly between the vertical arm assembly fastened to transmission. Fasten with hex capscrews and lock nuts as shown at "A" in Fig. 9. Tighten enough to take out excessive "play" but leave loose enough to pivot properly.

Mount the rear light support bracket to the seat back as shown, using a hex capscrew and lockwasher. Fasten the cable clip to the arm assembly as shown, with a hex capscrew, flat washer, lockwasher, and hex nut.

12. Attach the ground cable to the negative terminal of the battery.
13. Refill transmission with 1-1/2 quarts of SAE #90 Oil, and check drain plug, filler plug, and vent plug for tightness.

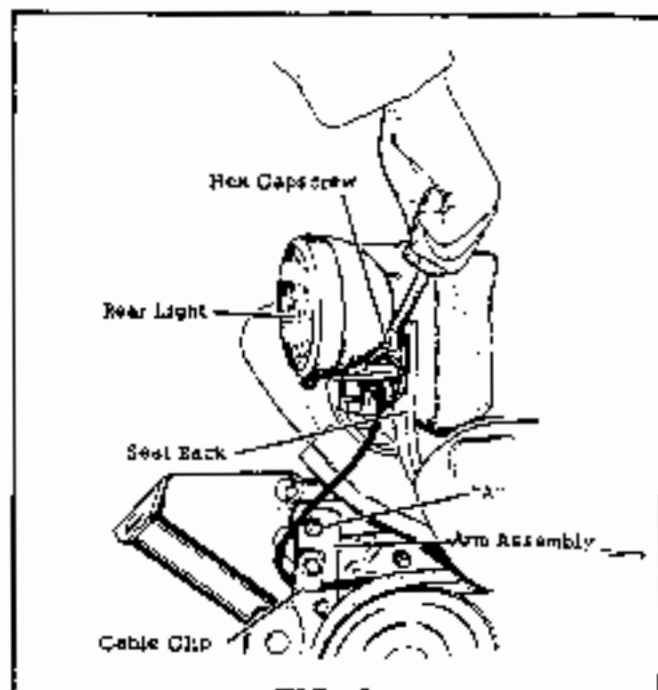

FIG. 9

HYDROSTATIC TRANSMISSION HB-112 and HB-212

A gear reduction unit is used on all models equipped with a hydrostatic transmission. A sliding drive gear is used in the gear reduction unit so that tractor may be moved manually. When gear shift lever (4—Fig. 1) is in vertical position, drive gear (21) will be engaged with reduction gear (43). To disengage gears, turn shift lever away from reduction housing.

CAUTION: Tractor brakes are inoperative when shift lever is in disengaged position.

REMOVE AND REINSTALL

All Models So Equipped

To remove the gear reduction unit, support tractor under main frame just ahead of bevel gear housing. Remove seat deck and fender assembly. Drain reduction unit housing. Remove rear wheels, hubs, differential assembly and axle shaft. Remove bevel gear pinion belt pulley and disconnect pinion tension spring. Support gear reduction housing and remove left side plate. Drain hydrostatic transmission reservoir, disconnect oil lines and

control rod, then unbolt and remove reservoir, oil cooler, shroud and cooler fan. Unbolt and remove hydrostatic transmission and brake band. Remove capscrews securing gear reduction unit to right side plate and lift the unit from tractor.

Reinstall by reversing the removal procedure. Fill reduction unit to level plug opening with SAE 90 EP gear oil. Fill hydrostatic reservoir with Dexon Type "A" automatic transmission fluid. Adjust brake and clutch idler linkage as required.

OVERHAUL

All Models So Equipped

To disassemble the gear reduction unit, remove brake drum and clean all paint, burrs and rust from

keyed end of axle tube (37—Fig. 1). Unbolt and remove cover (40) from case (17). Remove washer (27) and first reduction gear (23). Remove snap ring (14), then withdraw output gear and axle tube assembly (28 thru 37). Remove second reduction gear and shaft assembly (41 thru 45). Loosen set screw (46) and remove as a unit, the shift fork and rail assembly (7 thru 10) and the brake shaft assembly (18 thru 22). Use caution when removing shift rail (10) from shift fork (9) as popper ball and spring (7 and 8) will be released. Loosen locknut (5), remove shifter stem (6) and withdraw shift lever (4). Oil seals and needle bearings can now be removed from case and cover as required.

Clean and inspect all parts and renew any showing excessive wear or other damage. Using Fig. 1 as a guide, reassemble by reversing the disassembly procedure.

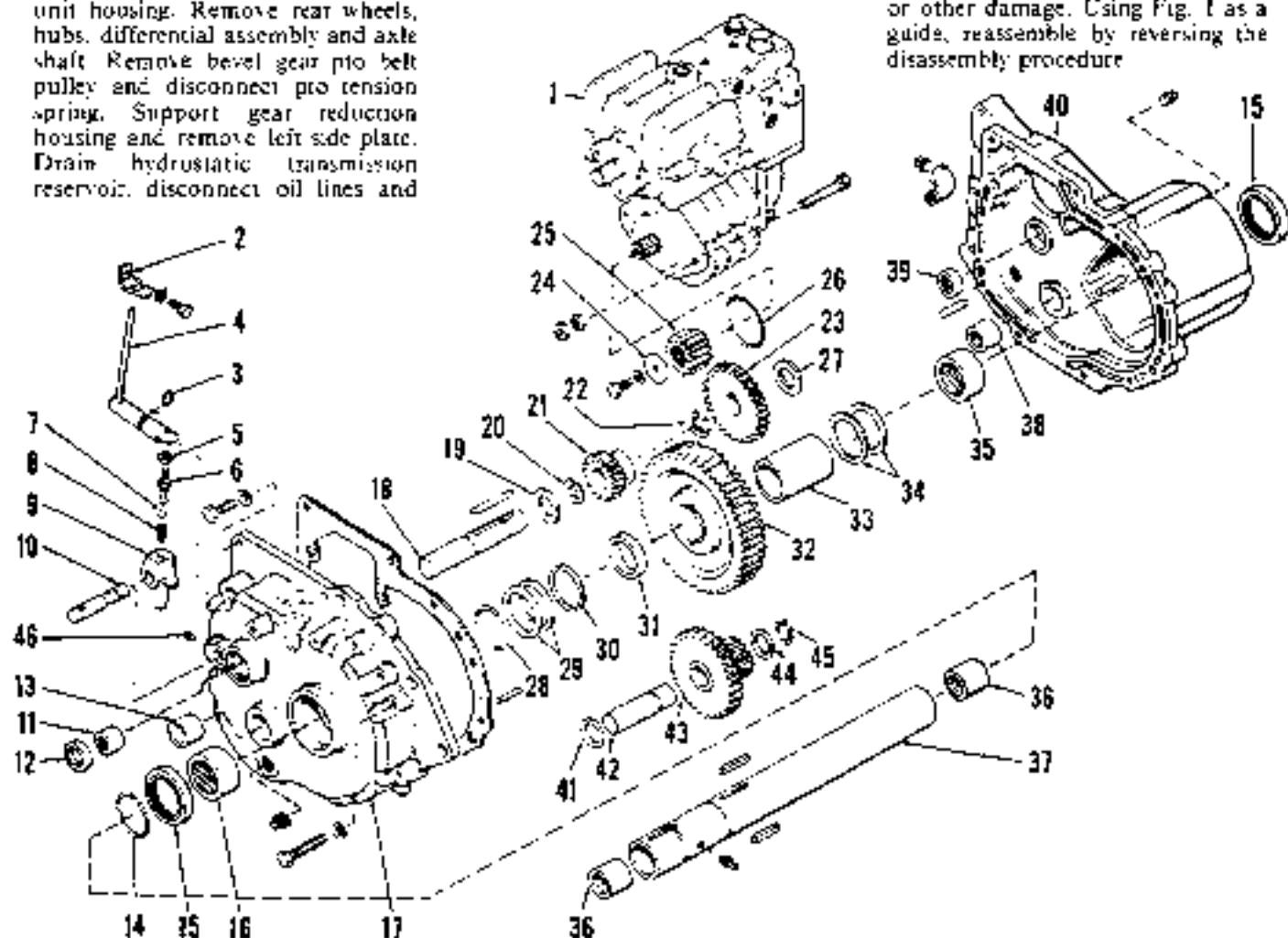

Fig. 1—Exploded view of gear reduction unit used on models equipped with hydrostatic transmission.

1. Hydrostatic transmission cover	8. Spring	16. Bearing	24. Washer	32. Ring gear	40. Cover
2. Level bush	9. Shift pin	17. Case	25. Input gear	33. Spacer	41. Washer
3. Oil ring	10. Shift fork	18. Brake shaft	26. Oil ring	34. Washer	42. Shaft
4. Gear shift lever	11. Bearing	19. Washer	27. Washer	35. Bearing	43. Pinion & gear
5. Nut	12. Oil seal	20. Shaft	28. Snap ring	36. Axle tube	44. Washer
6. Shifter stem	13. Bearing	21. First gear	29. Washers	37. Output gear	45. Snap ring
7. Ball	14. Oil seal	22. Oil ring	30. Washers		46. Set screw

B-207 and B-208 TRANSAXLE

Models B207-B208- Homesteader 8

REMOVE AND REINSTALL.

To remove transaxle, remove drive belt from transaxle pulley and remove brake band. Remove gear shift lever knob. Support rear of tractor frame and remove axle "U" bolts. Roll transaxle away from tractor.

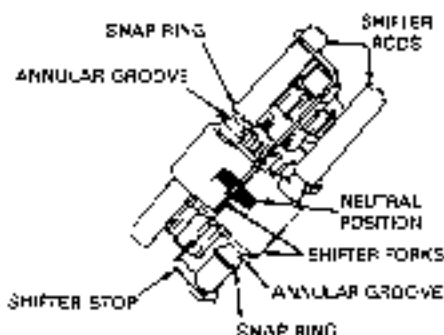

Fig. 1—To position shifter assembly in neutral for reassembly, align notches in shifter forks with notch in shifter stop.

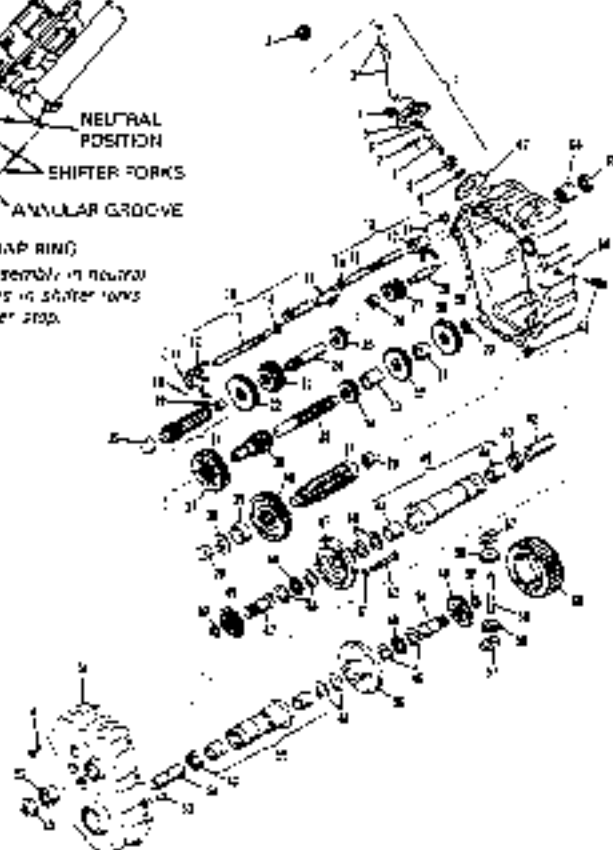

Fig. 2—Exploded view of transaxle used on models B207, B208

OVERHAUL. To overhaul transaxle, drain lubricant and remove input pulley, brake drum and wheel and hub assemblies. Place shift lever in neutral position. Unscrew shift housing cap screws and withdraw shift assembly from case. Remove all paint, rust and burrs from axle shafts and place transaxle in a vise with right (longer) axle pointing down. Unscrew case cap screws and drive out dowel pins.

Separate cover from case and lift cover up off the axle. Brake shaft (30—Fig. 2) and idler gear (29) will be removed with cover. Remove output shaft (41) with output gear (40), spacer (39) and washer (38). Withdraw the differential and axle shaft assembly and lay aside for later disassembly. Hold upper ends of shifter rods together and lift out shifter rods, forks, shifter stop, shaft (20) and sliding gears (22 and 23) as an assembly. Remove reverse idler gear (27), idler shaft (28) and spacer (26), then remove idler shaft (31) along with idler gears (32, 34 and 36) and spacers (33 and 35). Withdraw input shaft (24) and gear (25) from case. To remove brake shaft (30) and gear (29) from cover, block up under gear (29) and press shaft out of gear while being careful that pressure is not applied to cover during operation. Renew seals and bushings in axle housings (51 and 60) as required.

To disassemble differential, unscrew four cap screws and separate axle shaft and carriage assemblies from ring gear (68). Drive blocks (65), bevel pinion gears (66) and drive pin (67) can now be removed from ring gear. Remove snap rings (43) and slide axle shafts (45 and 57) from axle gears (44) and carriages (48 and 62).

Clean and inspect all parts for damage or excessive wear and renew as required. When installing needle bearings, press bearings into case and cover from inside and bearings are 0.015-0.020 below thrust surfaces. Renew all seals and gaskets and reassemble transaxle assembly by reversing disassembly procedure and noting the following points: Install reverse idler gear (27) in case so that rounded edge of gear teeth and spacer (26) will be toward cover. When installing idler shaft (31), place short spacer (35) between gears (34 and 36) and long spacer (33) between gears (32 and 34). Bevels on gear teeth of gears (32 and 34) must be on side of gear nearest large gear (36). When installing shifter assembly, position shifter rods in neutral position as shown in Fig. 1.

Tighten transaxle cap screws to the following torque:

Differential cap screws . . . 7 ft.-lbs.
Case to cover cap screws . . . 10 ft.-lbs.
Axle housing cap screws . . . 13 ft.-lbs.
Shift lever housing
cap screws 10 ft.-lbs.

ITEM	QTY	DESCRIPTION	ITEM	QTY	DESCRIPTION
1	1	TRANSAXLE ASSY, complete	24	1	GEAR, pinion
2	1	LEVER & HOUSING ASSY	25	1	SHAFT, idler
3	1	KNOS, shift	26	1	SPACER & BUSHING ASSY, idler
4	1	LEVER, shift	27	1	GEAR, idler
5	1	SCREW, cap screw, 1/4" x 1/2"	28	1	WASHER
6	1	HOUSING, shift stop	29	1	GEAR, output
7	1	RING, gear	30	1	SHAFT, output
8	1	PIN, cot	31	1	AXLE, idler
9	1	KEEPER, idler gear	32	1	GEAR, bevel
10	1	RING, gear	33	1	SPACER
11	1	BALL, steel	34	1	GEAR, output
12	1	SPRING	35	1	SPACER
13	1	FORK, shift	36	1	GEAR, output
14	1	ROD, shaft	37	1	GEAR, output
15	1	RING, gear	38	1	WASHER
16	1	STOP, shaft	39	1	SPACER
17	1	RING, gear	40	1	GEAR, output
18	1	RING, gear, idler	41	1	SHAFT, output
19	1	BEARING	42	1	BEARING
20	1	BEARING	43	1	SNAP RING
21	1	SHAFT & BEARING ASSY, output	44	1	AXLE, shaft
22	1	GEAR, output	45	1	AXLE, shaft
23	1	GEAR, output	46	1	BEARING
24	1	GEAR, input	47	1	BEARING
25	1	GEAR, input	48	1	CARRIER, differential
26	1	SPACER	49	1	BEARING, input
27	1	GEAR, idler	50	1	GEAR, bevel
28	1	SHAFT, idler	51	1	AXLE, housing
29	1	GEAR, output	52	1	BEARING
30	1	SHAFT, output	53	1	BEARING
31	1	AXLE, idler	54	1	BEARING
32	1	GEAR, bevel	55	1	BEARING
33	1	SPACER	56	1	BEARING
34	1	GEAR, output	57	1	BEARING
35	1	SPACER	58	1	BEARING
36	1	GEAR, output	59	1	BEARING
37	1	GEAR, output	60	1	AXLE, housing
38	1	WASHER	61	1	AXLE, housing
39	1	SPACER	62	1	AXLE, housing
40	1	GEAR, output	63	1	AXLE, housing
41	1	SHAFT, output	64	1	AXLE, housing
42	1	BEARING	65	1	DRIVE BLOCK
43	1	SNAP RING	66	1	BEVEL PINION GEAR
44	1	AXLE, shaft	67	1	DRIVE PIN
45	1	AXLE, shaft	68	1	RING GEAR
46	1	BEARING	69	1	BEARING
47	1	BEARING	70	1	BEARING
48	1	CARRIER, differential	71	1	BEARING
49	1	BEARING, input	72	1	BEARING
50	1	GEAR, bevel	73	1	BEARING
51	1	AXLE, housing	74	1	BEARING
52	1	BEARING	75	1	BEARING
53	1	BEARING	76	1	BEARING
54	1	BEARING	77	1	BEARING
55	1	BEARING	78	1	BEARING
56	1	BEARING	79	1	BEARING
57	1	BEARING	80	1	BEARING

TRACTOR
B-206

INDEX

Adjustments	F-24, E-25, E-26
Assembly of Transaxle to Tractor	E-36
Diagnosing Engine Difficulties	E-21
Differential	E-30, E-31
Lift Lever Kit	E-36
Maintenance	F-22, E-23, E-24
Removal of Transaxle	E-26
Rotary Mower, 26"	E-37
Seat Adjustment	E-39
Shifting Assembly and Disassembly	F-23, E-34, E-35
Shifting Lever Assembly and Disassembly	E-32
Snow Blade, 36"	E-36
Specifications	F-20, F-38
Storing the Tractor	E-23
Transaxle Assembly	E-30
Transaxle Disassembly	E-27, F-28, F-29

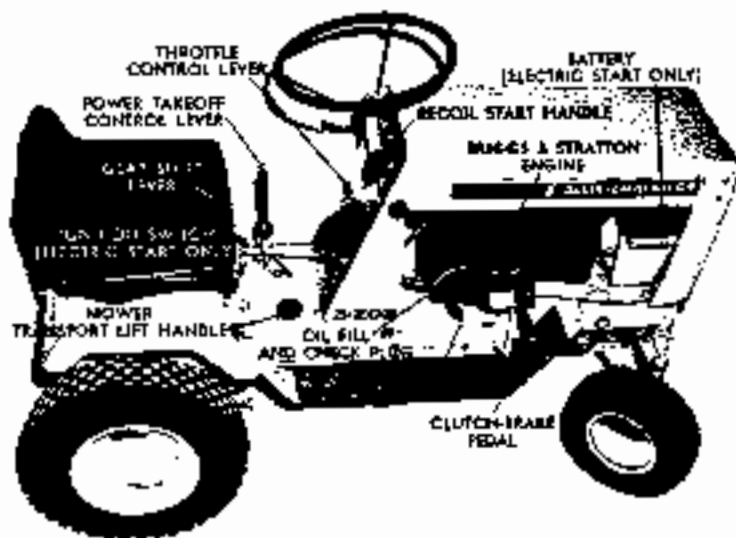

**B-206 TRACTOR
SPECIFICATIONS**

ENGINE COMPONENTS AND DRIVE

Horsepower	6
Make	Briggs & Stratton, Series 14670C
Bore and Stroke	2 3/4 x 2 3/8
Displacement	14.11 cu. in.
RPM	3600
Starter	Recoil (12 volt elec. w./4 amp. alternator opt.)
Governor	Mechanical-Adjustable-Full Lubrication
Transmission	Transaxle-3 speeds forward - 1 reverse
Differential	Bevel Gear, Internal to Transaxle
Eng./Trans. Drive	Heat and Oil Resistant Belt
Battery	25 AMP Hour (Optional w/Elec. Start)
Brake	Band Type, Combination Brake and Clutch Pedal
Clutch	Belt Type, Belt Tightening Idler Pulley

CAPACITY

Eng. Crankcase	2 1/4 pts.
Fuel Tank	2 quarts

SPEEDS

First	1.27 MPH
Second	2.48 MPH
Third	3.70 MPH
Reverse	1.78 MPH

DIMENSIONS

Height (at top hood)	28.75"
Height (at steering wheel)	34"
Width Overall	25.5" (27.5 with tires reversed)
Length Overall	59.25"
Wheel Tread (Center to Center)	20.5" (22.5 with tires reversed)
Wheel Base	39.75"
Clearance (front axle)	8"
Clearance (differential)	4.5"
Clearance (drawbar)	8.5"
Front Tire Size	11.00 x 3.75-8
Rear Tire Size	4.80/4.00-8
Turning Radius	36" (inside rear wheel)

SHIPPING WEIGHT

B-206	325 lbs.
B-206E	350 lbs.

DIAGNOSING ENGINE DIFFICULTY

Engine Hard Starting

1. Loose or grounded high tension, or breaker point leads.
2. Improper breaker point gap.
3. Faulty spark plug.
4. Faulty condenser on coil.
5. Incorrect spark timing.
6. Gasoline not getting to carburetor.
7. Dirt or gum in carburetor or fuel line.
8. Carburetor improperly adjusted.
9. Valves leaking or sticking.
10. Piston rings worn excessively.
11. Cylinder head gasket leaking.

Engine Overheating

1. Insufficient available cool air.
2. Dirty air intake screen, shroud or cooling fins.
3. Improper fuel.
4. Fuel mixture too lean.
5. Improper ignition timing.

Engine Backfiring

1. Fuel mixture too lean.
2. Sticky intake valve.
3. Improper ignition timing.

Engine Missing at High Speed

1. Spark plug gap too wide.
2. Improper carburetor adjustment, or lack of fuel.
3. Wrong type spark plug, use spark plug that is recommended.
4. Improper timing.

Engine Missing Under Slow Hand Full

1. Spark plug gap too wide.
2. Pitted breaker points.
3. Partially fouled spark plug.
4. Defective ignition cable.

Engine Knocking

1. Fuel octane rating too low.
2. Engine overheated.
3. Improper timing.
4. Loose connecting rod.
5. Excessive carbon in combustion chamber.

Engine Operating Erratically

1. Clogged fuel line.
2. Water in fuel.
3. Faulty choke control.
4. Improper fuel.
5. Loose ignition system connections.
6. Air leaks in manifold or carburetor connections.

Engine Will Not Idle

1. Improper carburetor idling adjustment.
2. Carburetor jets clogged.
3. Spark plug gap too narrow.
4. Leaking carburetor or manifold gaskets.
5. Sticking or leaking valves.
6. Weak coil or condenser.

Oil Changes

NOTE: Tractor should be on a level surface before changing oil.

The oil should be changed after the FIRST 5 hours of operation then each 25 hours of operation thereafter.

To change the oil, first remove any dirt or trash buildup from around oil filler plug.

Then drain the crankcase, while the engine is warm, by removing the oil drain plug (Fig. 3). Once all of the oil has been drained, replace the oil drain plug and remove the oil filler plug. Refill the crankcase with a high quality detergent oil classified "For Service MS" (motor severe). Nothing should be added to the recommended oil.

Summer Winter (Below 40°F)
Use SAE 30 Use SAE 5W-20 or SAE 10W

Fill the crankcase, pouring oil slowly, to capacity (2 1/4 pints).

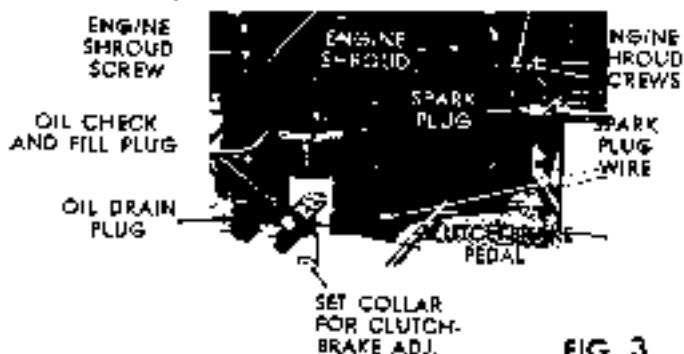

FIG. 3

CLEAN AIR AND CLEAN ENGINE OIL WILL GIVE LONG TROUBLE-FREE OPERATION. DIRT WILL RUIN YOUR ENGINE IN A SHORT TIME.

Air Cleaner

The air cleaner element should be removed, cleaned and reoiled after every 25 hours of operation under normal conditions. More often in dusty, dry, or windy conditions.

To service air cleaner (Fig. 4) loosen the 2 hood holddown knobs and tilt the hood forward.

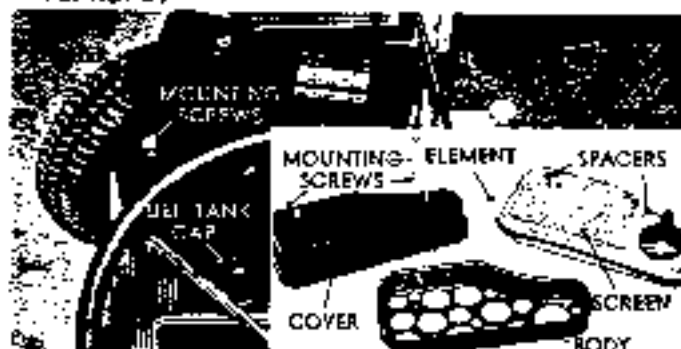

FIG. 4

1. Remove the two screws and lift off the entire air cleaner assembly.
2. Remove the cover, then the spacers and screen from the foam element.
3. Remove the foam element from the air cleaner body.
 - A. Wash foam element in liquid detergent and water or kerosene to remove dirt.
 - B. Wrap foam element in clean, dry cloth and squeeze to remove wetness.
 - C. Saturate foam element in engine oil, then squeeze to remove excess oil.
 - D. Assemble air cleaner completely, making sure that the tongs on the cup type spacer are positioned as shown—then mount to carburetor with screws.

NOTE: When assembling air cleaner, make sure that the lip of the foam element extends over the edge of air cleaner body. The element lip will form a seal when tightened down.

Engine Cooling

The flywheel screen should be checked each time the air cleaner is serviced and any dirt, grass, etc., should be removed.

Also, the engine shroud should be removed periodically in order to dislodge any foreign matter that may have accumulated around the cylinder and fins at front of engine. If not connected, these conditions will restrict air flow around the engine, causing it to run hot and therefore, shorten engine life. To service engine shroud, remove (4) four screws.

Alternator (Fig. 5)

The Alternator on this tractor is equipped with a fuse for safety purposes. If a fuse needs changing, read WARNING before replacing the fuse.

WARNING: For electrical safety always remove cable from negative (-) side of battery before removing fuse. Replace fuse, then battery cable.



FIG. 5

STORING YOUR TRACTOR

When your tractor is not to be used for some time, it should be stored in a dry protected place. Leaving your tractor outdoors, exposed to the elements, will result in materially shortening its life.

Preparing Tractor for Storage

If the tractor is to be stored for more than 30 days, follow this recommended procedure.

1. Disconnect the spark plug wire, drain the fuel tank completely, then reconnect spark plug wire.
2. Start engine and run until all fuel has been consumed.
3. While engine is still warm, drain and refill crankcase with fresh oil (See Oil Changes)
4. Remove spark plug and pour 2 or 3 tablespoons of SAE-30 oil into the plug port. Turn the crankshaft over a few revolutions by pulling the recoil handle out a couple of times or on electric start models by turning the key to the "Start" position for a couple of seconds. This distributes oil throughout the internal engine system and prevents damage (rust, etc.) to the engine while stored! Replace the spark plug.
5. Clean any dirt or grass from the cylinder fins and flywheel screen.
6. Remove battery and store in a cool dry place above freezing. Keep battery fully charged.
7. When tractor is removed from storage, it should be serviced thoroughly, including draining and refilling the crankcase with fresh oil.

Starting Engine After Storage

1. Remove spark plug and wipe dry, crank engine rapidly until excess oil has been blown out of spark plug hole. Replace spark plug.
2. Fill the fuel tank.
3. Install a fully charged battery and be sure the proper connections are made.
4. Service air cleaner.
5. Drain crankcase and refill with fresh clean oil.
6. Start engine and let it run slowly for the first few minutes. Move tractor outside of storage room, or keep all doors open. Do not operate engine at high speeds immediately after first starting.

7. Inflate tires to the correct operating pressure before operating tractor.

MAINTENANCE - B-206 TRACTOR

Lubrication

The B-206 Tractor should be lubricated at the points designated below with a good grade of light machine oil or Allis Chalmers Chain and Cable Lube. (Fig. 1 and 2).

1. Front Axle Vertical spindles.
2. Steering.
3. Axle Linkages.
4. All pivot points.

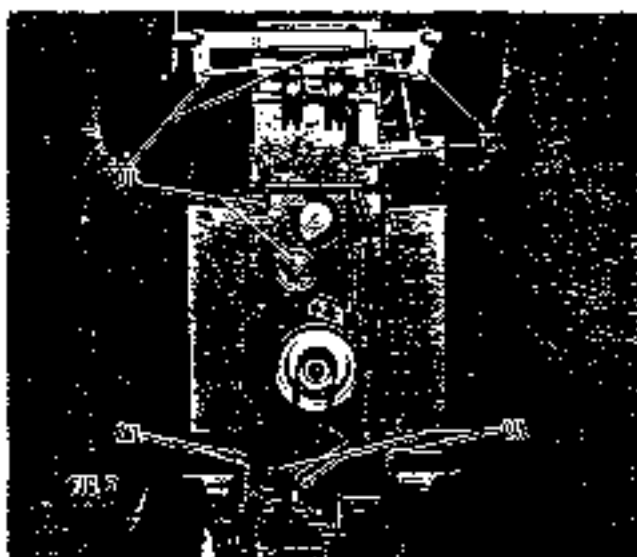
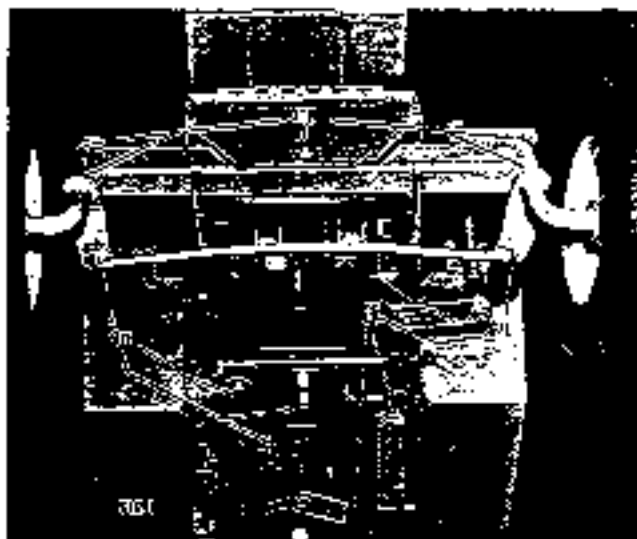

Oil Checks

The oil level should be checked before starting the engine and after each 5 hours of operation.

Battery - Electric Start Models Only

The battery should be kept clean and dry at all times. Keep battery snugly fastened in place and check battery cables for tight connections. Vent caps should be kept tight and vent holes in vent caps must be kept open at all times to permit gases formed in battery to escape. Do not overfill. Keep filled so solution is 3/16" above separators.

The battery is shipped installed in the tractor, but contains no electrolyte. Remove battery from tractor. Fill each cell to the indicator level with an electrolyte solution of 1.250-1.265 specific gravity. Temperature of battery and electrolyte must be between 60°F and 90°F. Allow battery to stand 20 minutes. Check each cell and add electrolyte as necessary to restore level to indicator. Give battery minimum charge at 20 amperes for 10 minutes or until the temperature of the electrolyte reaches 80°F. Reinstall battery in tractor.

Check each time engine is serviced to insure that the electrolyte level is maintained at approximately 3/16" above the plates. Add distilled water, when necessary, to bring electrolyte (battery solution) up to proper level.

Should the battery become discharged and need charging it can be charged on equipment with a 110 volt plug-in battery charger. Before charging read CAUTION carefully. **CAUTION:** 110-volt plug-in charger will not bring battery up to charge unless cable is disconnected from negative (-) side

WIRING DIAGRAM

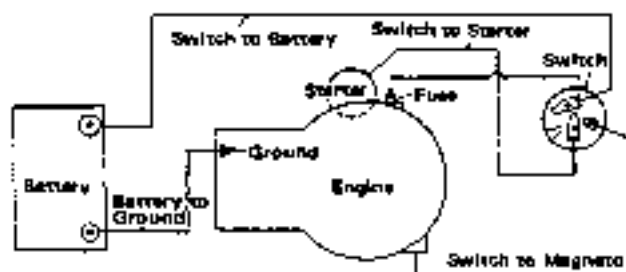

FIG. 5

of battery. Do NOT run engine with battery disconnected unless the fuse is removed from the fuse holder. Failure to remove the fuse can result in electrical sparking and alternator damage.

If tractor is not used for an extended period during winter, remove battery and store in a fully charged condition in a cool place.

Transmission (Fig. 7)

The transmission has a capacity of 1 1/2 pints of SAE 90 oil and is filled at the factory. It will not normally require replenishment, but occasionally check drain plug for tightness and axle tube oil seals for leakage. Keep oil up to level of filler plug.

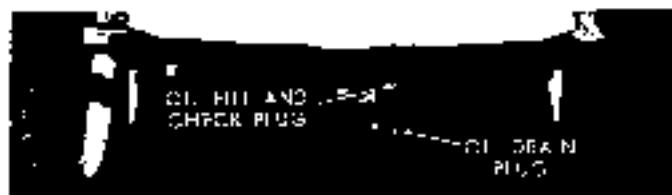

FIG. 7

Tires

The tires of the tractor are inflated with air pressure in excess of the normal amount for shipment. For comfort of operation, release some of the pressure until a pressure of 12 lbs. per square inch is attained for rear tires. Maintain tires at this pressure. Front tires are semi-pneumatic no pressure.

ADJUSTMENTS

Carburetor (Fig 8)

The carburetor has been adjusted at the factory, but due to different locations and climatic conditions, minor adjustments may be necessary.

Initial Adjustment

Turn needle valve clockwise until it closes.

CAUTION: Be careful not to close needle valve too tight as this may damage the valve.

Now open the needle valve approximately 1 1/8 turns counterclockwise. Close and reopen the idle valve in the same manner. The initial adjustment will be sufficient to start the engine and make final adjustments.



FIG. 8

NOTE: Let the engine warm up before going to the Final Adjustment procedures.

Final Adjustment

Close the needle valve until the engine makes a misfire (skips). This misfire indicates a "lean mixture" of air and fuel. Now, open the needle valve out past the smooth operating point until the engine begins to run unevenly (bouncy). This indicates a "rich mixture" of air and fuel. Then close the needle valve slowly to the midpoint between the "lean" and "rich" points so that the engine runs smoothly.

Now move the throttle lever to the idle position, then set (turn) the idle speed adjusting screw until the engine runs at a fast idle (approximately 1,150 RPM). Next, turn the idle valve in (lean mixture) then back out (rich mixture) and then set the valve to the midpoint or until the engine idles smoothly. Now reset the idle speed adjusting screw until the engine idles at 1,750 RPM.

To check for correct settings of final adjustments, move the throttle control lever to the "Fast" position—the engine should accelerate without hesitation or skipping. If hesitation and/or skipping is encountered, readjust the carburetor to a slightly richer setting.

General Tune-Up

The engine manufacturer recommends the following spark plugs for replacement:

	A-C	Autolite	Champion
Spark Plug	GS-45 or GS-46	A7N or A71	CJ-8 or J-8
Spark Plug Gap	.030"		
Ignition Point Gap	.020"		
Intake Valve Clearance	.005"-.007"		
Exhaust	.009"-.011"		

Clutch-Brake Adjustments (Fig. 9, 10, 11)

NOTE: When adjusting Clutch or Brake follow the entire procedure.

With the Idler Pulley held tight against the belt position and lock the Set Collar 1/8"

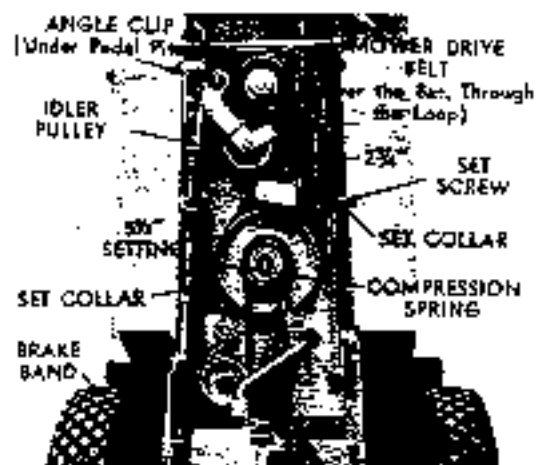

FIG. 9

from the Angle Clip. This adjustment is made with an Allen wrench through a slot on the right side of the frame (Fig. 9). To adjust the Compression Spring on the Brake Rod, compress the Spring to a length of 5 1/2" with Set Collar and then lock in place with set screw in collar.

For Brake Band adjustment, pull lower flange of the Brake Band forward to tighten brake and lock set collar 1/4" to 3/16" from flange.

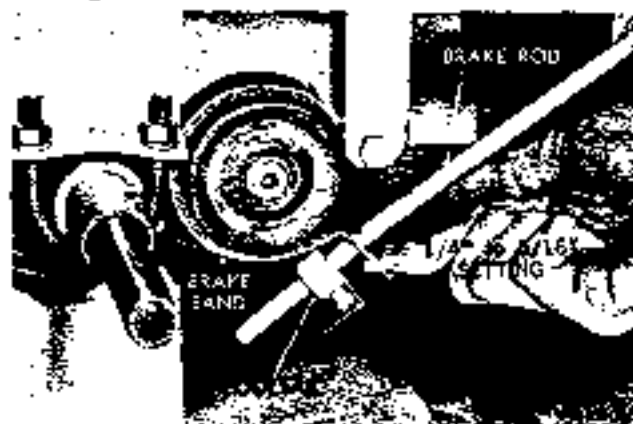
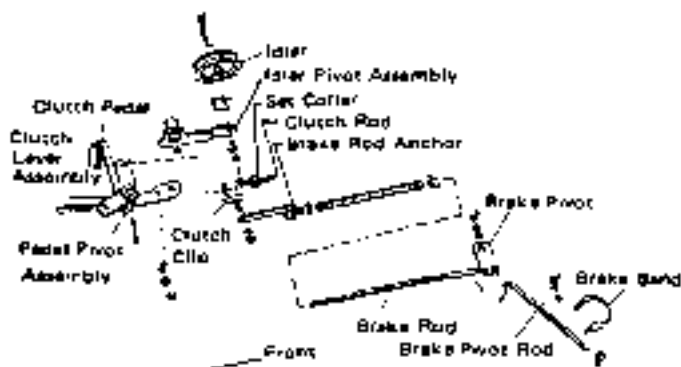

FIG. 10



Power Take Off Control Lever (Fig. 12)

The P.T.O. Lever need not be adjusted unless an implement such as a rotary mower is to be used.

To adjust P.T.O., with mower attached, position Set Collar on P.T.O. Rod Assembly such that the Spring is compressed to a length of $2\frac{3}{4}$ " with the P.T.O. Lever in the "ENGAGED" (Forward) position.

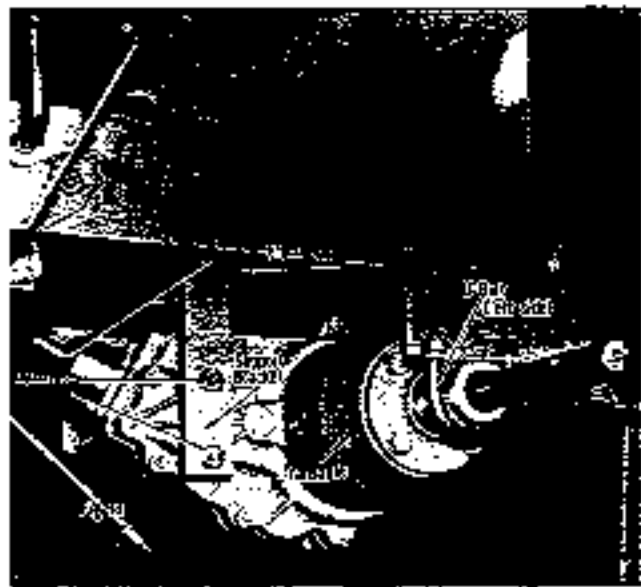
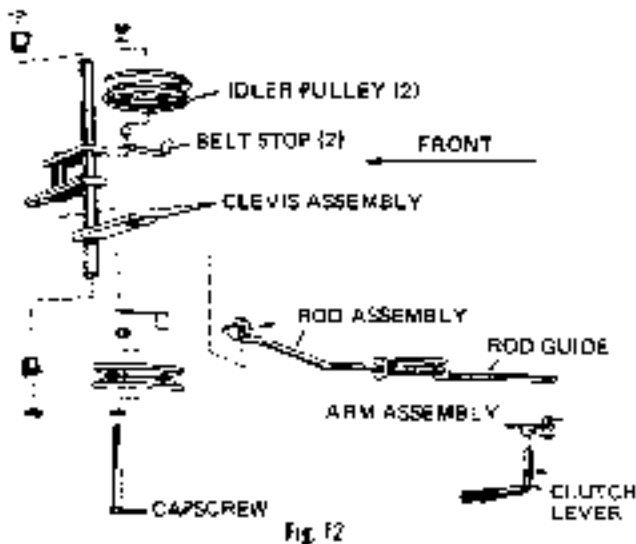

LEFT SIDE FIG. 13

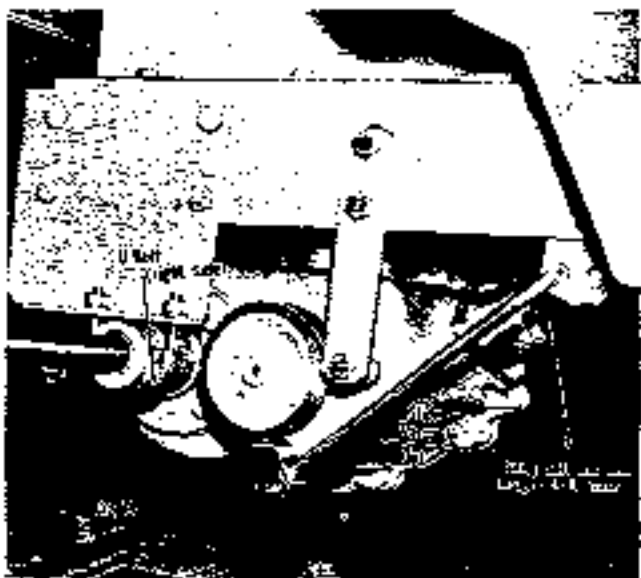

RIGHT SIDE FIG. 14

Removal of Transaxle (Figs. 13 & 14)

To remove the transaxle from the tractor, proceed in the following sequence of steps.

1. Lift or jack up the tractor to a point where the rear wheels are free of the ground. Place a support strong enough to bear the weight of the tractor at a point under the frame ahead of the P.T.O. pulley.
2. Disengage and remove transmission drive belt.
3. Remove hub caps from wheels.
4. Remove (2) snap rings from grooves (one at each end of transaxle). Slide wheels off axle. Remove axle spacers and washer from each end of axle.
5. Remove shifter lever knob.
6. Loosen and remove 3 capscrews connecting 1602064 bracket to frame and transaxle on left side - remove bracket.
7. Remove 4 washers and nuts and 2 "L" brackets holding transaxle to frame.
8. Standing at rear of tractor, lower the left side of the transaxle until the shift lever has passed through the frame and then slide the transaxle to the left until free of the brake band and frame.

Note: The Brake band and rod do not have to be disassembled to remove the transaxle.

Transaxle Disassembly

1. Clean the outside surface of the trans-axle, away from the area where dis-assembly will take place. (Position shift lever in neutral position to help dis-assembly. See Figure 15. Remove screws (3) holding shift lever and shift lever housing. Remove shift lever housing. Drain oil through the shift lever opening (for service of shift lever assembly, refer to Page 18). Remove all keys from keyways, remove all burrs and dirt from shafts. On hardened shafts, use a stone to remove burrs. All seals should be replaced whenever a shaft is pulled through a seal. Always use a new gasket whenever the gasket surfaces have been separated.

2. After removing axle housings, place the unit in a receptacle, bench or clamp the transaxle in a soft jaw vise. Position the transaxle so that the socket head cap screws are facing up.

3. Remove the socket head cap screws hold- ing the case and cover together. Drive out the dowel pins used for alignment of the case and cover.

4. Lift off the cover assembly. Use a seal protector on axle shaft and lift off trans-axle cover assembly. Because this seal is a single lip type, it may be reused, if care is taken to see that it isn't scratch- ed or cut. Discard gasket.

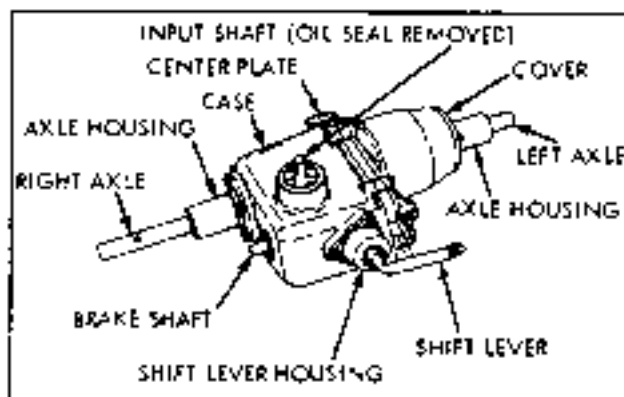

Figure 15

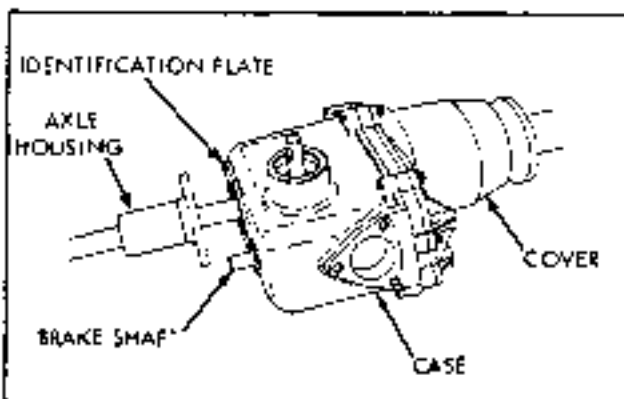

Figure 16

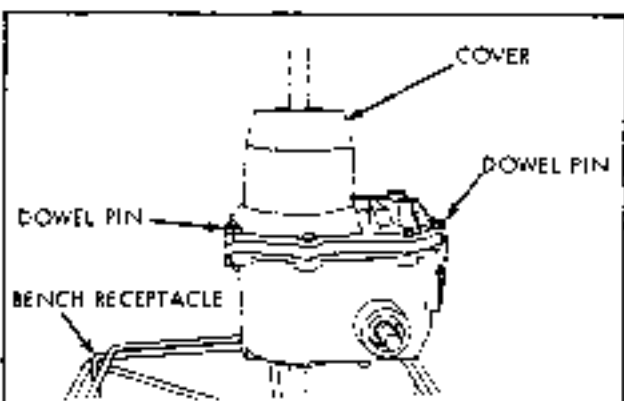

Figure 17

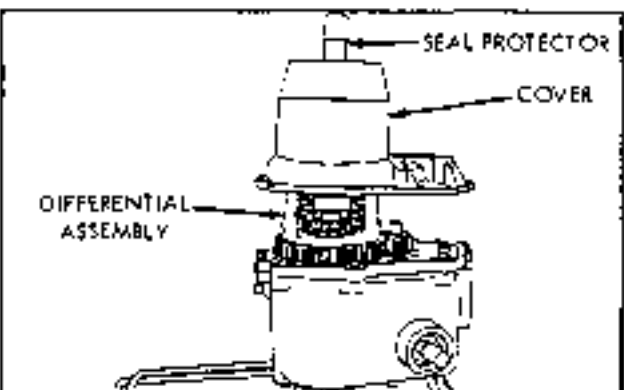

Figure 18

6. To remove differential assembly, it may be necessary to replace two or three screws to hold center plate assembly down. Pull assembly straight up. If tight, tap on lower axle with soft mallet. **CAUTION:** Do Not Use Steel Hammer. Refer to Page 13 for differential assembly service. Remove gear on top of shifter shaft.

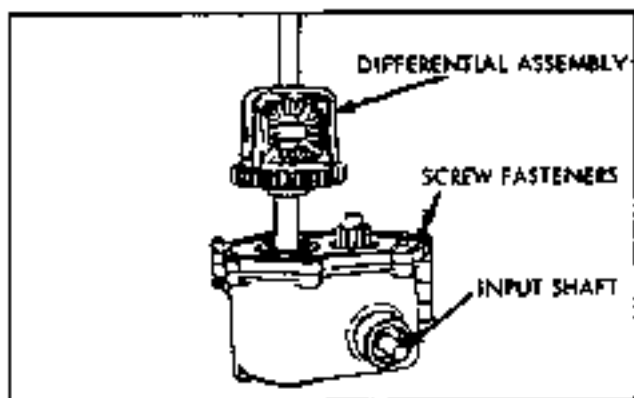

Figure 19

6. Remove temporary holding screws, if used, and lift off center plate assembly. Discard gasket.

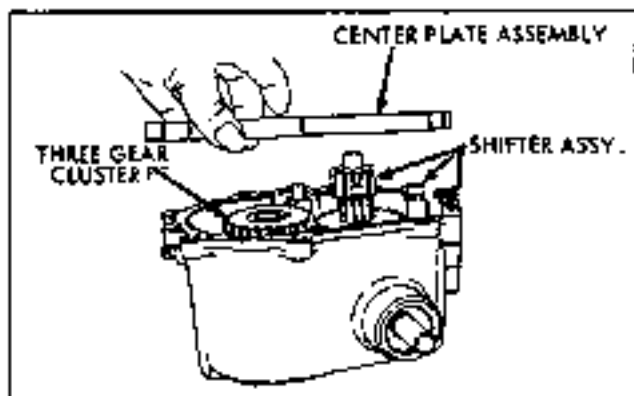

Figure 20

7. Remove complete shifter assembly by grasping shifter gears, shaft and both shifter rods as a unit. **NOTE:** Examine assembly carefully; if no service is required, retain assembly as a unit for easy reassembly. If service is necessary, refer to Page 16. Also, refer to illustrations 23 and 25 and paragraph (13) on next page.

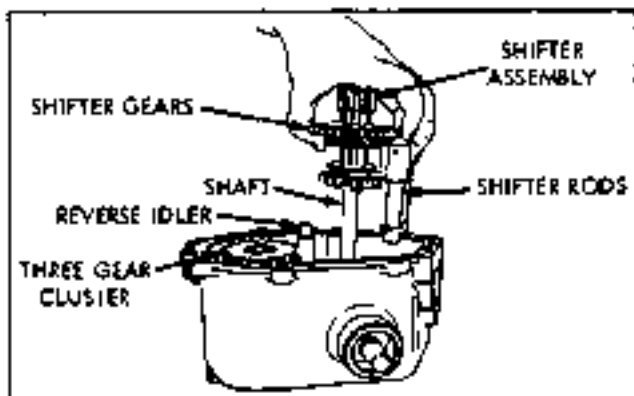

Figure 21

8. Remove reverse idler shaft and spacer, cluster gear assembly and thrust washers. For removal and replacement of gears on cluster, see paragraph (1) on next page.

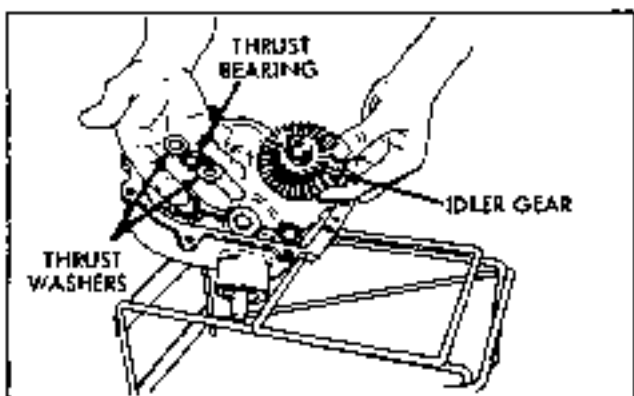

Figure 22

9. Lift idler gear assembly out of case.
 NOTE: For sequence of thrust washers and bearings, See Figure 22).
 NOTE: Caution required as needed from shifter and brake shaft bearing may fall out.

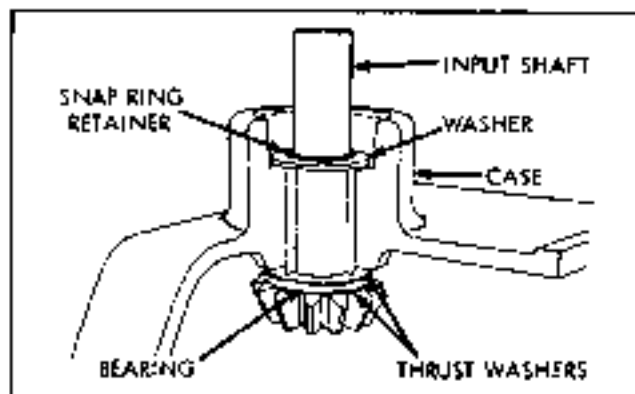

Figure 23

10. Remove input shaft oil seal to allow access to snap ring. Remove snap ring and input shaft will slide out. A removed seal must be replaced by a new seal.

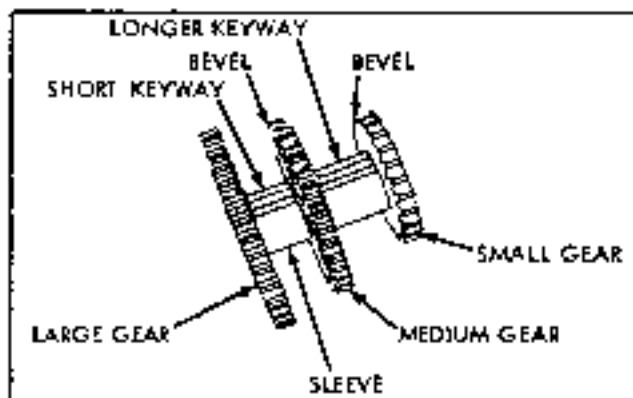

Figure 24

11. Cluster Gear Sub-Assembly
 (a) The cluster gear can be disassembled. All gears are replaceable if damaged or worn. Preferably use a press to drive the gears squarely.
 (b) The small and middle gear bevel faces down, there is no beveled edge on large gear. Shorten section between middle and large gear.
 (c) Key edge ends must align with shaft ends.

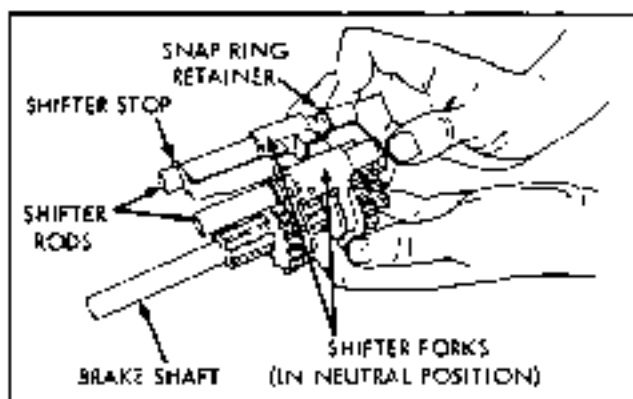

Figure 25

12. Shifting Assembly

The shifting assembly is usually removed from and installed into the transaxle as a unit. The assembly is removed and replaced by grasping the shifting rods firmly. This will cause the pinning necessary to hold the assembly together. Before removal, or installation of the shifting assembly, notches in the shifter forks should be aligned with notches in the shifter stop. This indicates that shifting assembly is in a neutral position. The shifter stop must be so positioned that the notch aligns with notches in shifter forks. For service of the shifting assembly, refer to Page 16.

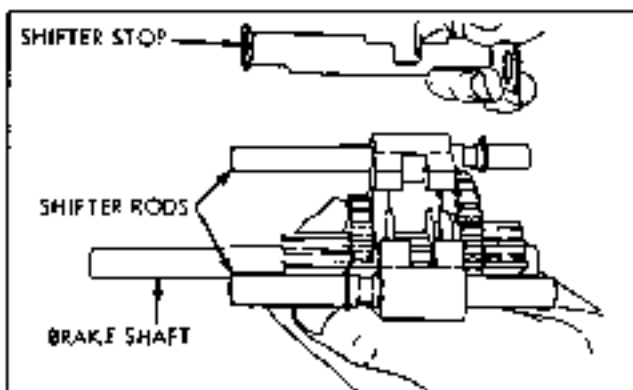

Figure 26

13. Transaxle Assembly

(a) Install thrust washers and bearing on input shaft. Note sequence, Fig 27.

(b) Install input shaft into case assembly. Lock on with snap ring retainer. Install oil seal.

(c) Set case assembly open side up. Insert the idler shaft gear assembly, thrust washers and bearing. Note sequence of washers and bearings (Fig 22).

Note: Place reverse idler shaft into bearing to aid in holding washers, thrust bearing, idler shaft and gear assembly prior to installing shifter assembly.

(d) Insert the washer and then the three gear cluster assembly.

(e) Insert shifter assembly. Check that rods are seated properly.

Note: Reverse idler shaft will be pushed out at this time.

(f) Install reverse idler. Make sure beveled edge is up. Spacer on top of gear.

(g) Place new gasket on case and install center plate.

(h) Place new gasket on center plate and install differential assembly, longer axle in down position. Be sure gear on shifter shaft is on shaft.

(i) Install gear case dowel pins. Leave dowel pins slightly exposed on top to locate cover assembly.

(j) Install transaxle cover assembly, and secure with eight (8) cap screws.

(k) Install bearings and/or bushings, if necessary. Install seal.

(l) Install axle housing assembly. Fill with 1/2 pints S.A.E. EP 80 oil.

(m) Inspection Note: For a neutral position, shift notches in forks and notch in shifter stop must be aligned and centrally located.

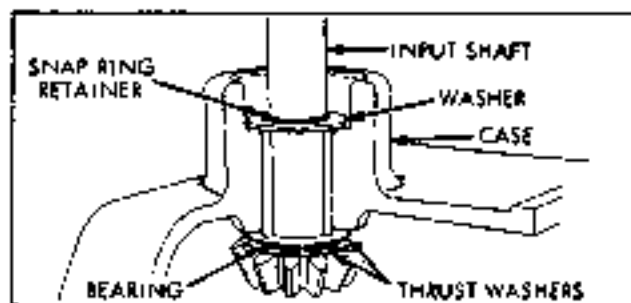

Figure 27

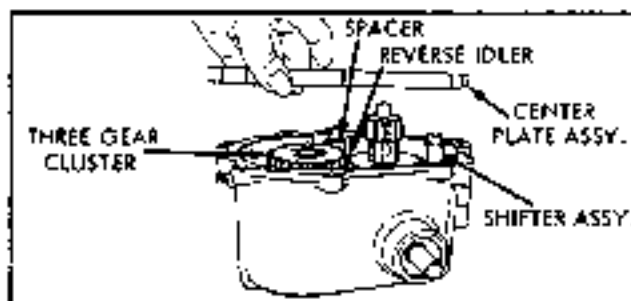

Figure 28

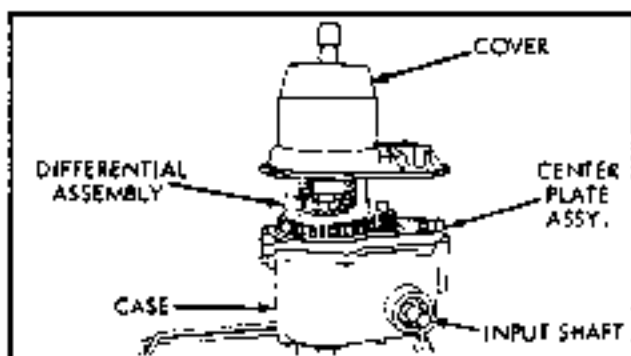

Figure 29

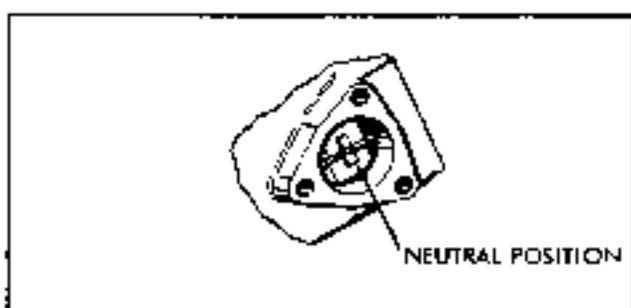

Figure 30

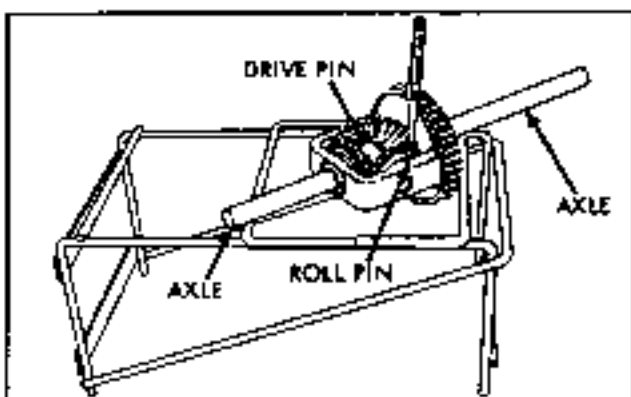

Figure 31

DIFFERENTIAL

C. Model 500

1. Disassembly

(a) Drive out roll pin that secures drive pin with suitable driver.

(t) Remove drive pin.

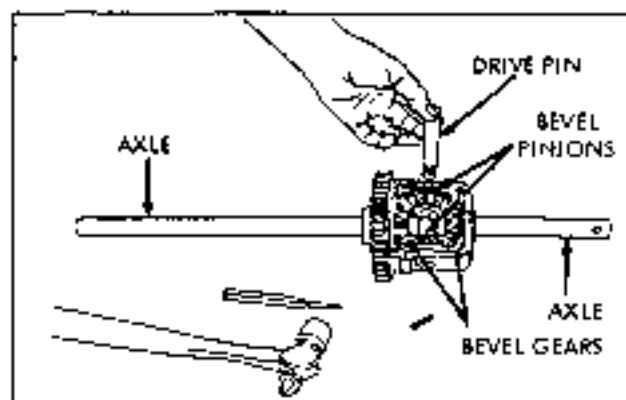

Figure 32

(c) Thrust washers must be removed before attempting to remove the pinions. Remove bevel pinions simultaneously by rotating the gears in opposite directions; gears will move out of position.

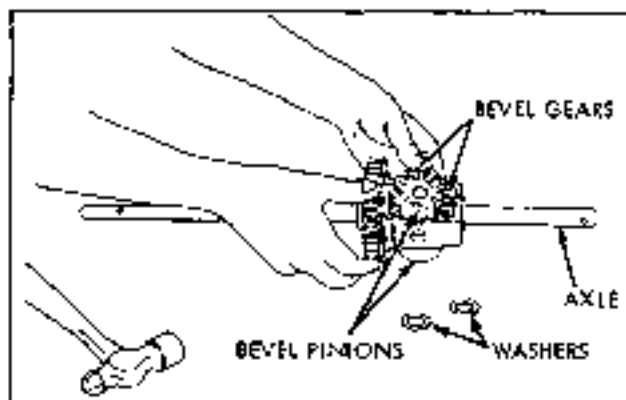

Figure 33

(d) Drive out double roll pin and slide axle out. On roll pin drive types, drive the bevel gears from the axle. See Figure 34.

(e) On double "D" type drives, remove snap ring, bevel gear and thrust washers. Slide axle out. See Figure 35.

(f) Inspect bushings and gears for wear and replace when necessary.

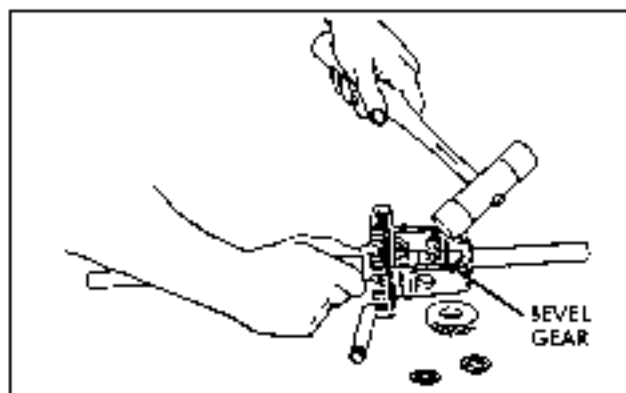

Figure 34

2. Reassembly of Differential: Assembly

(a) Place axles (left and right) into differential gear assembly. Install thrust washers.

Note: The axles differ in length so select the proper axle.

(b) On roll pin drive models, install double roll pins into holes in each shaft. Place bevel gears on shaft. Roll pins fit into the recess in back of the gears; bevel gears must be seated tightly on the roll pins or binding will occur. See Figure 35.

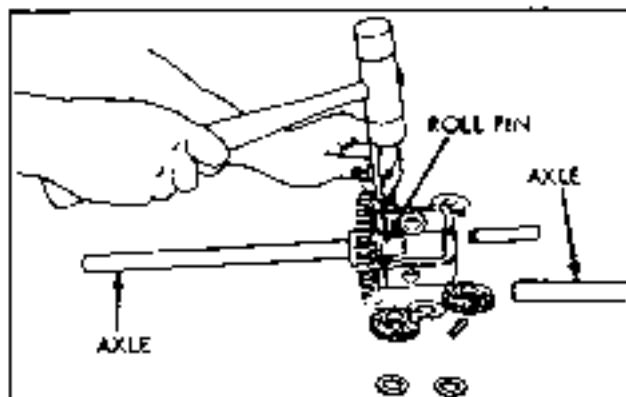

Figure 35

(c) On double "D" type drives, place bevel gears on the shaft and install snap ring in groove on the shaft. See Figure 36.

(d) Install bevel pinions **SIMULTANEOUSLY FROM OPPOSITE SIDES** by rotating pinions in opposite directions while sliding into position in gear assembly. See Figure 33. Check alignment by inserting fingers into drive pin holes. If not aligned, drive pin cannot be inserted. Remove and replace bevel pinions as only one tooth out of position will cause misalignment.

(e) After aligning, insert thrust washers behind each pinion. Insert drive pin and secure with roll pin.

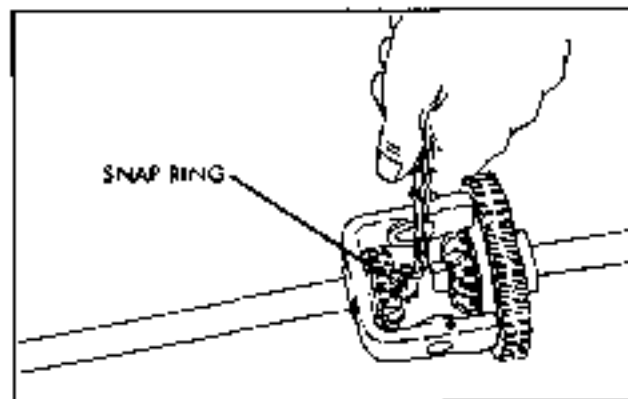

Figure 36

A. SHIFT LEVER ASSEMBLY

1. General

(a) Prior to removing a shift lever assembly from a transaxle, make note of the position of the shift lever so that it may be assembled correctly to the shift lever housing.

(b) Move the shift lever to Neutral, if possible, before removing it from the transaxle. Clean around the lever housing to prevent dirt from falling into the transaxle. Cover this opening, if possible.

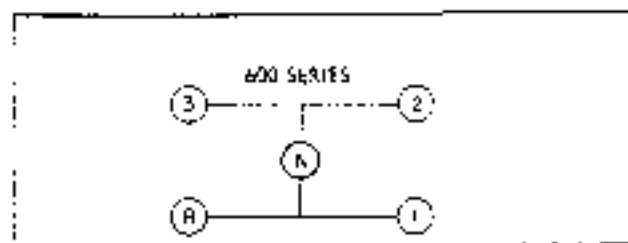

Figure 37

2. Disassembly

(a) Place the shift lever in a vise so that the shift lever housing is at least one inch from the top of the vise jaws.

(b) Dowel Pin Type. Locate the dowel pin holding the retainer in the housing from the outside (Fig. 38). Place a 1/4" flat face punch on the gasket surface directly over the dowel pin. Strike the punch sharply but lightly with a hammer to dislodge the retainer from the shift lever housing. Always use a new dowel pin for reassembly.

Snap Ring Type. Use the proper compressing type tool for removing the snap ring. Loosen the vise and disassemble the pieces (Fig. 39).

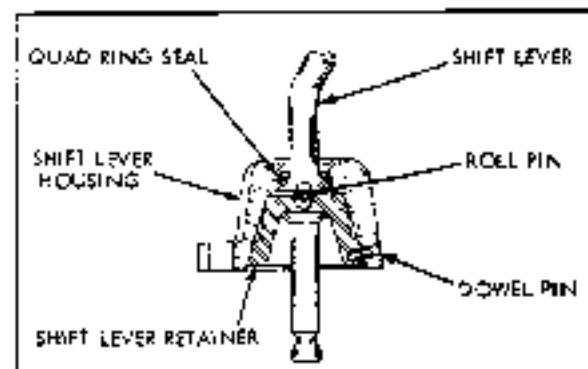

Figure 38 Dowel Pin Type Shift Lever

(c) Remove the shift lever from the shift lever housing. Examine the roll pin in the ball of the shift lever. (Fig. 38) If bent or worn, replace. When inserting a new roll pin in the ball, position so that equal lengths protrude from both sides of the ball.

(d) Oil leakage past the point where the shift lever enters the shift lever housing will require replacement of the quad ring seal in the shift lever housing.

(e) Prior to reassembly, be sure that bends in the shift lever correspond to the mounting on the vehicle.

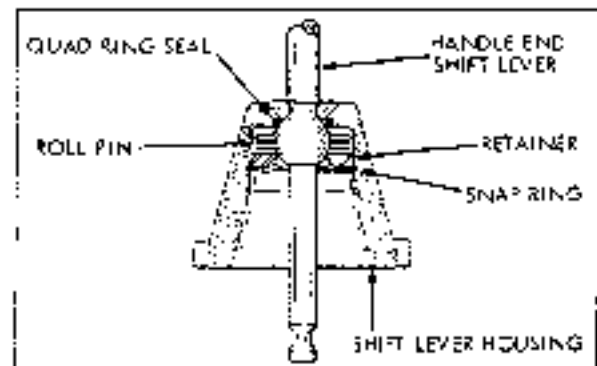

Figure 39 Snap Ring Type Shift Lever

3. Reassembly

(a) Dowel Pin Type. Secure with a new dowel pin. A second dowel pin is used in some assemblies for alignment. This dowel pin is located in the gasket surface of the shift lever housing and fits into a mating hole in the transaxle.

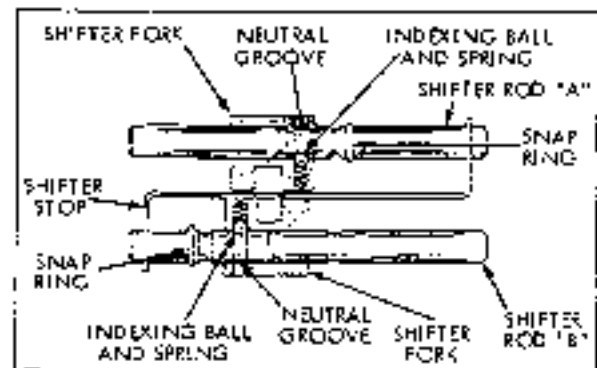

Figure 40 Three Stop Three-Speed Transaxle Shifter Rod and Fork Assembly

- (b) Snap Ring Type. Secure parts with the snap ring. Before installing the shift lever and housing to the transaxle housing, check the shifting forks for Neutral position.
- (c) Always use new gaskets between the shift lever housing and the transaxle.

C. SHIFTING ASSEMBLY

1. General

(a) Shifting assemblies are removed from and installed into transaxles by squeezing the top end of the shifter rods. This causes a pinning that retains all parts during removal or installation.

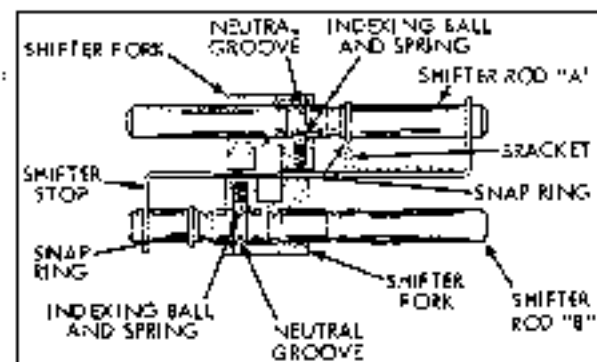

Figure 41 Four Stop Three-Speed and Four-Speed Transaxle Shifter and Fork Assembly

2. Disassembly

Follow the illustrations in order - Figs. 46, 45, 44, 43, 42, 41. Prior to disassembly compare the assembly with the illustrations. This will aid during the reassembly.

3. Inspection

- (a) Replace the shifter stop if worn or damaged.
- (b) Examine the teeth and internal splines of the two shifter gears. Replace damaged gears. The gears must slide freely on the shifter shaft. Excessive wear of the internal spline in the gears will create locking and difficult shifting. Replace the gear if this condition is present.
- (c) Replace the shifter shaft needle bearing if wear is evident. Replace if the bearing surface of this shaft should it be scuffed, pitted or worn to a diameter less than .750".
- (d) Replace other parts showing wear, looseness, cracks, etc.

4. Assembly

- (a) Reassemble the shifting assembly by following the illustrations beginning with Figures 41 through 46. Pay particular attention to either Figure 39 or 40 during the reassembly of the shifter forks and shifter rods. Lay the parts on the bench in the same manner as illustrated in Figure 39 or 40 on a clean paper or shop cloth. Pay particular attention to the annular grooves in the shifter rods and the snap ring.

- (1) Assemble the shifter forks to the shifter rods as illustrated in Fig. 41. The shifter forks are interchangeable.
- (2) Refer to Fig. 41. Slide the shifter fork onto the shifter rod until it comes to the hole with the indexing ball and spring. With a flat blade screw driver press the indexing ball into the hole and move the shifting fork completely onto the shifter rod.

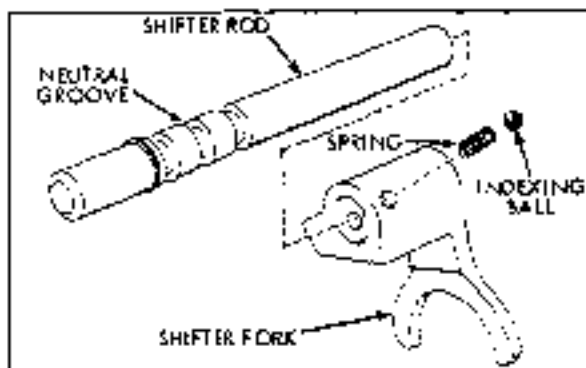

Figure 42 Assemble Shifter Forks to Shifter Rods

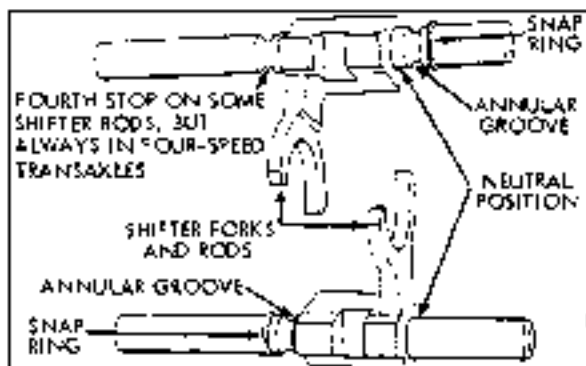

Figure 43 Shifter Forks and Rods Positioned in Neutral

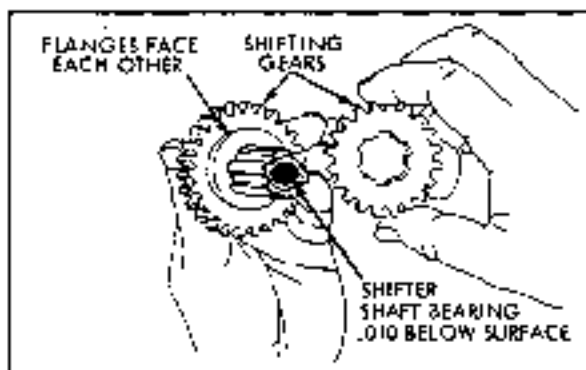

Figure 44 Two Flanged Gears onto Shifter Shaft

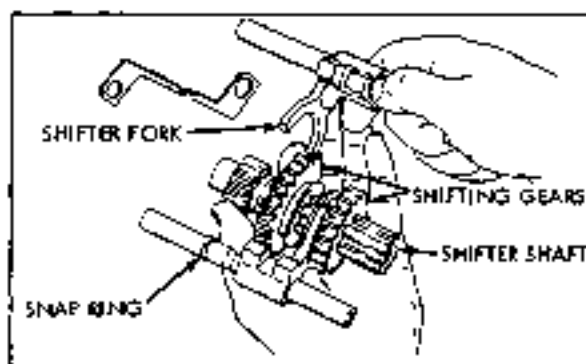

Figure 45 Assembling Shift Fork, Gears and Shaft Assemblies

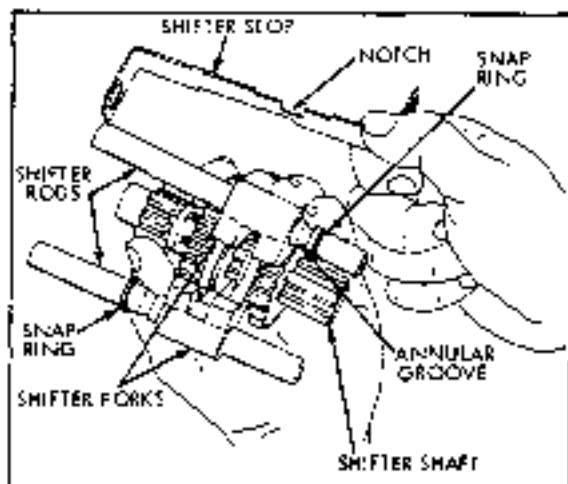

Figure 46 Positioning Shifter Stop

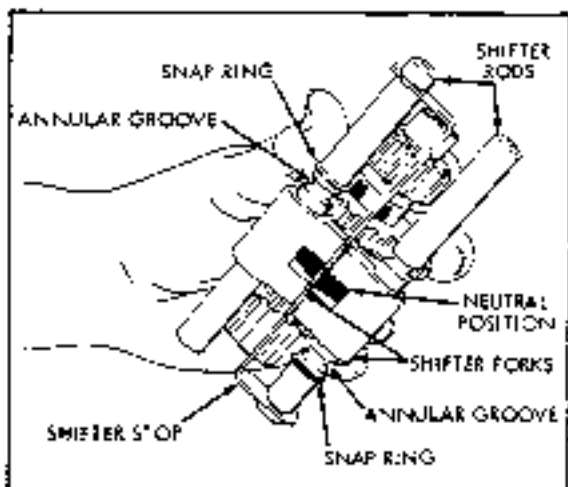

Figure 47 Final Assembly

(3) Move the shifting fork to the Neutral position. The neutral groove is the center groove. If the shifter rod has four grooves, the neutral groove is the second groove from the shortest end. This neutral groove can be seen through the hole in the shifter fork. See Figures 39 and 40, the arrow from the "Neutral Groove" is passing through the hole for view.

(4) When the shifter forks are properly assembled to the shifter rods and positioned in neutral, the ends of the notches in the shifter forks are in alignment. (Figure 47).

(b) Assemble the two flanged gears onto the shifter shaft. (Figure 43) Note that the large gear is placed on the shaft first with the flange side toward the needle bearing in the end of the shifter shaft. Slide on the smaller gear with the flange toward that of the larger gear. (Figures 43,44).

(c) When assembling the shifter fork and rod to the flanged gears on the shifter shaft, Figure 45, that shifter fork which is on shifter rod "A" always engages in flange in the larger gear. To determine which is shifter rod "A" compare the parts to illustrations, Figure 39 and 40. Hold the shifter shaft in the hand as illustrated (Figure 43) during assembly.

(d) After the shifter fork and rod assemblies have been engaged with the flanged gears allow the shifter rods to lay open in the hand and position the shifter stop. (Figure 45). The notch in the shifter stop is the guide for correct positioning. Align this notch with the corresponding notches in the shifter forks and insert the shifter stop. Move the shifter rods together, (Figure 46) and insert into the transaxle. Remember to squeeze the ends of the shifter rods to cause the assembly to bind and stay together.

(e) In three speed transaxles the needle bearing end is inserted first into the case to engage the end of input shaft.

(f) When placing the shifting assembly in into the four speed transaxle be sure the thrust washer is on the bearing. Place the assembly into the transaxle with the needle bearing end of the shifter shaft up. Allow the end of the shifter shaft to protrude below the ends of the shifter rods, this will ease the alignment of the assembly.

(g) The shifter assembly is correctly installed in the transaxle if the notches in the shifter forks are just about in the center of the bearing in the case or cover of the transaxle.

ASSEMBLY OF TRANSAXLE

Care should be taken when reassembling the transaxle to the frame of the tractor not to damage the brake band and brake rod. The following sequence of steps should be followed:

1. Standing at the rear of the tractor: Hold the transaxle with the brake drum on the left and the shift lever up, tilt the right end of the transaxle up slightly and slide it to the right allowing the shift lever to pass through the hole in the frame. The brake drum should fit inside the brake band.
2. Reassemble 2 "U" brackets (one on each end of axle shaft) to frame and fasten to frame with 4 washers and nuts.
3. Fasten 1502064 bracket to frame and transaxle with 3 capscrews, washers, and nuts the long side of the bracket should extend down and rearward from the bottom of the frame.
4. Slide a wheel spacer on each end of the transaxle. Assemble wheels on axle and assemble snap ring in groove outside of each wheel. Replace hub caps. Note: Wheel width of rear wheels can be changed by reversing the face of the wheel hub on the axle. If both wheels are assembled with deep dish side of hub toward the transaxle a narrow stance can be obtained.
5. Install transmission drive belts.
6. Adjust brake and clutch per this manual: page 8

LIFT LEVER KIT

Assembly

The Lift Lever Kit is necessary if you wish to mount the 35" Snow Plow and Dozer Blade to your B-205 Tractor. To assemble on B-206 Tractor, proceed as follows:

1. Assemble quadrant to tractor frame by inserting hub of quadrant into hole on right side of frame below B-205 pedal with the flange up and out from tractor. Fasten quadrant to frame by inserting two capscrews into two holes through the quadrant and frame. Fasten each cap-screw with a lockwasher under each hex nut.
2. Put handle grip onto Lift Lever.
3. Slide Lift Lever shaft into hole in quadrant and through the frame.

4. Assemble Lift Arm Assembly with the headed pin toward the Lift Lever. The Spindle Collar should slide onto the end of the Lift Lever Shaft. Align the holes in the spindle collar and lift lever shaft. Insert the grooved pin through the spindle collar hole.
5. The remaining washer and quick pin are assembled on the headed pin of the lift arm assembly when attaching the Dozer Blade.

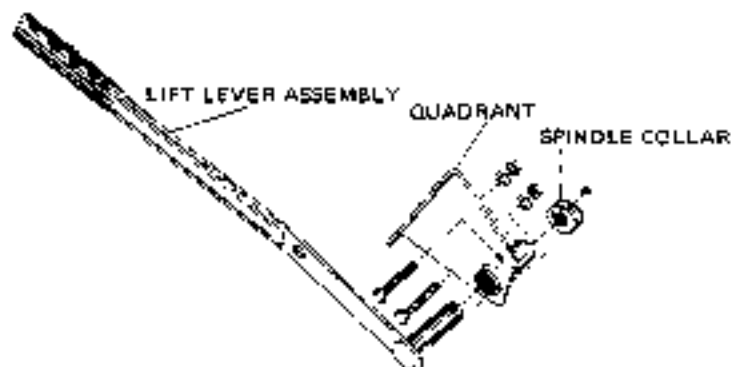

FIG. 49

35" Snow Plow and Dozer Blade

Attaching the Blade

The Blade is attached to the B-205 Tractor by means of the Blade Support Plate which comes with the Blade Assembly Kit. For effective operation, the Lift Lever Kit is required when the Blade is used.

Mount the Blade Support Plate to the front of the tractor with the (3) three bolts, lockwashers and nuts provided. Once the plate is secured, align the holes of the Push Bar Assembly with the holes in the Blade Support Plate and connect with the Pivot Bar. Make sure that the Pivot Bar is secured with the Quick Pins on both sides of the Push Bar.

Now align the holes in the Lift Rod Yoke with the hole in the upper right arm of the Push Bar Assembly. Insert Yoke Pin and lock in with the Quick Pin.

Put the rear end of the Lift Rod through the hole in the Lift Lever and lock in with the washer and Quick Pin. The blade is ready to use.

NOTE: When using the Blade for plowing snow, added traction can be obtained by using Wheel Weights and Tire Chains.

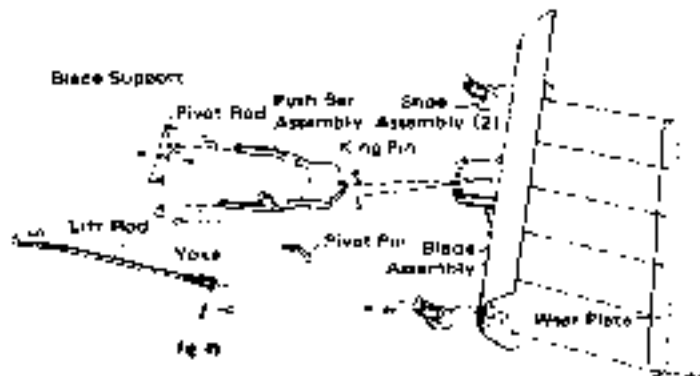

Blade Adjustment

The blade is adjustable to (5) angle positions: straight ahead, 2 positions to the left and 2 positions to the right. To position the blade, remove the Pivot Pin, swing blade to desired position and replace Pivot Pin.

To adjust the Blade lift height, pull the Quick Pin from the Yoke Pin, remove the Yoke Pin, loosen the Jam Nut on the Lift Rod and turn the Yoke clockwise to raise or counter-clockwise to lower. Tighten the Jam Nut back up to the Yoke and fasten the Lift Rod back up with Yoke Pin and Quick Pin.

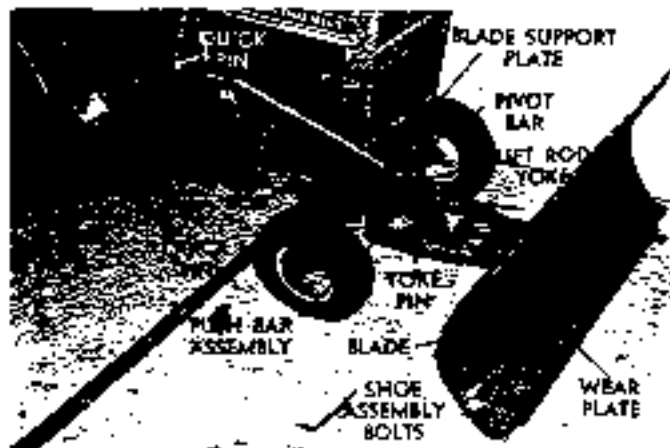

FIG. 50

The Blade can be adjusted to operate at three different heights. To change the operating height, remove two bolts holding each shoe assembly and reassemble the shoes to another pair of holes in the Blade. Lowering the shoe assembly on the Blade will raise the operating height of the Blade and vice versa.

26" Rotary Mower

The B-206 Lawn and Garden Tractor is equipped so that the Rotary Mower can be attached with ease.

The mower comes assembled and has all the necessary hardware included so that it can be attached to the tractor.

Blade Installation

When installing a mower blade, observe that blade tips are up and bolt is securely tightened.

Attaching the Mower

To attach the mower to the tractor, first park the tractor on level ground. Move the P.T.O. Lever to the "Disengaged" (rear) position. Put the mower down on the right side of the tractor so that it faces perpendicularly away from the tractor (Fig. 51). Turn the front wheels of the tractor hard to the left to give a clear access to the underneath. Push the mower straight in under the tractor to the point where it can be turned 90° to face in the same direction as the tractor (Figure 52).

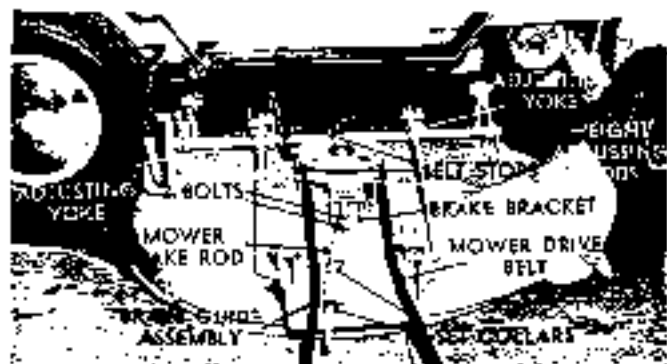

FIG. 51

Once the Mower is aligned into position the Mower Drive Belt must be connected.

The mower drive belt must be looped up and over the two power takeoff (P.T.O.) pulleys. The belt must be twisted slightly so that it will pass between the outside tip of the pulley and the belt retainers. Next, run the belt over the center crossbar (between the crossbar and the retainer loop—Fig.50), and connect it around the Engine Pulley (Fig.53). This satisfies the power hookup for the mower.

Now the Mower Brake Lever must be connected. This is done by putting the stud of the Guide Assy. through the hole in the Mower Brake Arm and securing with the flat washer and hair cotter pin provided (Figure 54).

Now lift the front of the mower up and back so that the lock studs on each side of the Mower Arm will drop down into the slots of the Mower Quick-Disconnect Assembly. (Fig. 52)



FIG. 52

Put the MOWER TRANSPORT LIFT HANDLE attached to the MOWER LIFT CHAIN up through the hole in the frame and screw the KNOB provided onto the HANDLE. The Mower can now be raised or lowered from the operator's seat. (Fig. 53).

Leveling the Mower

Rotate the blade to the front and engage the PTO Control Lever. Measure the distance from the floor to the bottom of the blade tips both at the front and at the rear. The front blade tip should be approximately 1/8" lower (nearer the floor) than the rear tip.

To raise the blade tip at the front, turn the Yokes on the Adjusting Rods clockwise (counterclockwise to lower) (Fig 51).

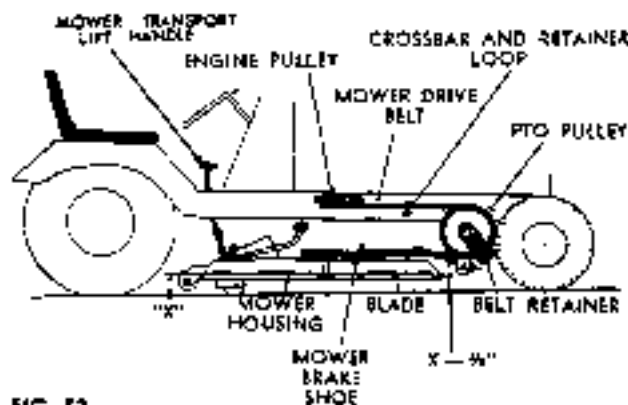

FIG. 53

Once the front blade tip is in adjustment, disengage PTO Control Lever, rotate the blade 90° (tips of blade pointing to tractor sides) and then engage PTO Control Lever. Measure the distance from the floor to the blade tips. The measurements should be the same within 1/8".

Adjusting the Mower Brake

Position the brake so that the face touches both tips of pulley, then tighten the two (2) bolts holding the Brake Bracket to the Mower Housing (Fig. 51).

Engage the PTO Control Lever and pull the Brake Assembly into the disengaged position. Move the rear Set Collar up against back face of the Guide Assembly and lock into place with the Setscrew. Now position the front Set Collar approximately 1/8" to 3/16" out in front of the Guide Assembly and lock it into place with the Setscrew. Be sure that the Setscrews in the Set Collars are positioned out to the side (Fig. 54).

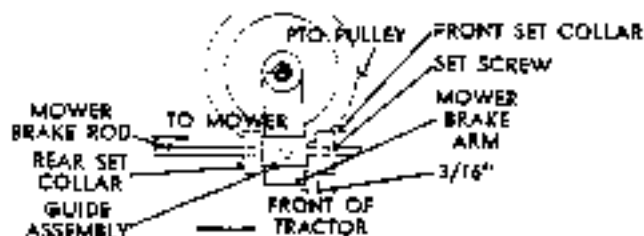

FIG. 54

MOWER SPECIFICATIONS

- Blade-----Single Blade
- Width of Cut-----26"
- Mower Brake-Positive Stop PTO Activated from Seat.
- Cutting Heights-----1" - 3"
- Mower Blade- Clutch Mounted for Protection from Internal Damage
- Mower Mounting-----Quick Attach to Front Axle

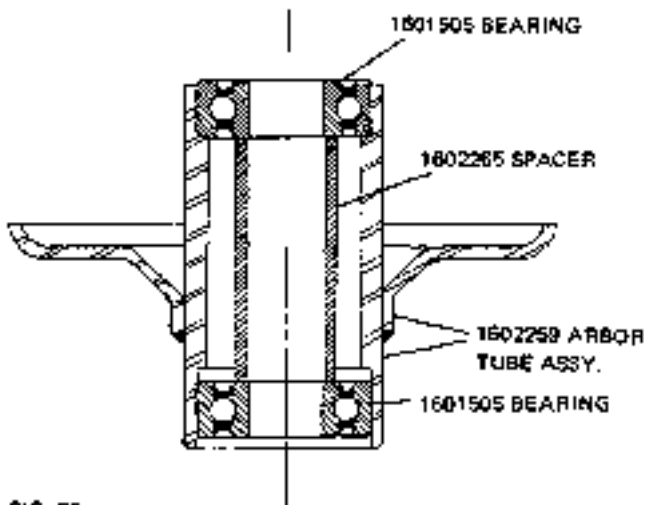

FIG. 55

Mower Arbor Tube Assembly (Fig. 55)
Should it be necessary, the following steps for assembling the Mower Arbor Tube Assembly should be followed.

1. Press 1601505 Bearing, with shield side out flush against upper shoulder of 1602259 Tube Arbor Assy. (Use equal pressure on inner and outer races of bearings).
2. Insert 1602265 Spacer into center of 1602259 Tube-Arbor Assy.
3. With the upper bearing resting on both inner and outer races, press 1601505 Bearing, with shield side out, flush against lower end of 1602265 spacer. (Use Equal pressure on inner and outer races of bearing).

Seat Adjustment

The seat may be adjusted to three positions front to back. Follow the steps outlined below: (Fig. 56, & 57).

1. Untie the string at right rear of seat and lift seat cushion from seat pan.
2. Loosen and remove four nuts and screws underneath frame holding seat pan.
3. Slide seat pan so that four holes for desired seat position line up with holes in frame.

4. Replace four screws and nuts and tighten.
5. Replace seat cushion on seat pan and tie securely.

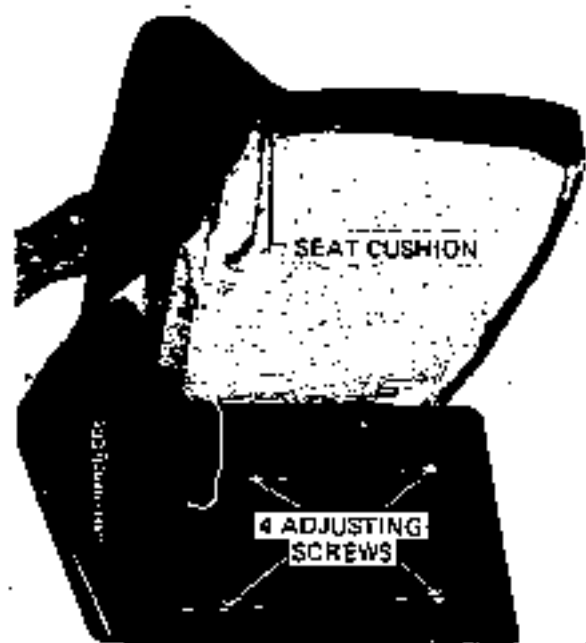

FIG. 56



FIG. 57

Two Speed Pulley

A. Removing Pulley Kit from the tractor:

1. Block up the rear of the tractor and remove the right rear wheel. Fig. 1.
2. Remove the Shift Fork Assembly by removing the locknut and long pivot bolt.
3. Next remove the capscrews holding the support to the drawbar and seat support. The support, pivot bracket and stop can now be removed from the tractor in one piece.
4. Disconnect the spring from the belt idler arm and remove the belt from the pulley.
5. Shift the pulley assembly into low range by grasping the shift ring with both hands and pulling out.
6. Rotate the shift ring and cover assemblies until the setscrew over the shaft keyway is aligned with one of the holes in the pulley hub. Loosen setscrew. The other setscrew in the collar need not be loosened at this point as it merely holds the collar in position on the Spicer Assembly. Fig. 2.

Slide the Pulley Kit off the transmission shaft.

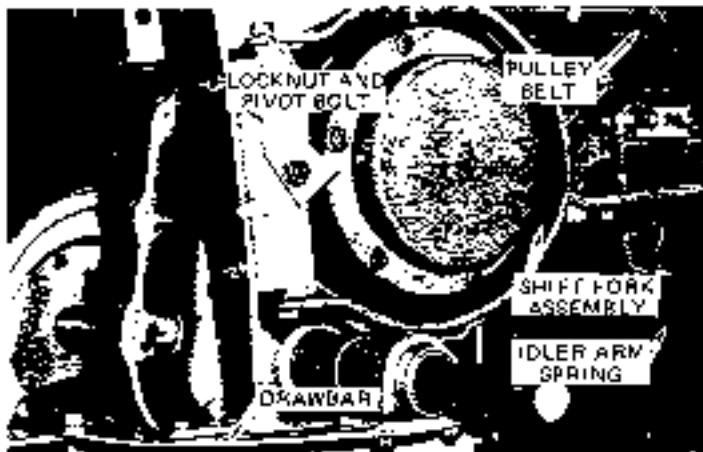

B. Disassembly of Pulley Kit

1. Place pulley kit in a vise with pulley side up. Clamp lightly on outer cover assembly so as not to deform the cover. Fig. 3.
2. Before attempting to remove the set collar, back the long setscrew out a few more turns to make sure it is not engaging the hole in the shaft. Loosen second setscrew and remove the set collar and pulley assembly by lifting upward. Fig. 4.



- Remove the six flange nuts and cap-screws holding the two cover assemblies, ring gear and shift ring together. Carefully lift the L.H. (inner) cover assembly and shift ring so as not to tear the gaskets. Fig. 5.

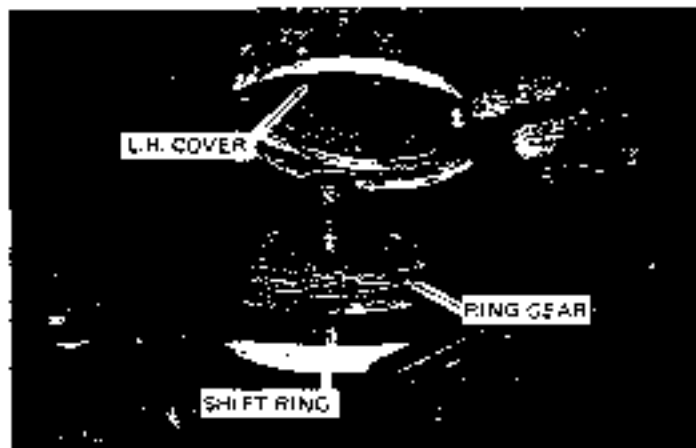

- To remove the R.H. (outer) cover assembly from the Spider Assembly, grasp the spider shaft in the left hand and hold the cover a couple inches above a bench. Insert a bar into the spider shaft bore and drive the cover out of Spider Assembly. Fig. 6.



- The ring gear and pinions can be disassembled by removing the three locknuts that hold the ring assembly and pinions to the spider. Fig. 7.
- Thoroughly clean and inspect all parts. Replace bearings, gears and other parts that are excessively worn.



C. Assembly & Lubrication

- Place Ring Assembly on a flat surface with studs pointing up. Fig. 8.
- Install three spacers and three pinions on studs. Apply a small quantity of Shell Durina EP #1 grease to bore and sides of pinions before placing over the spacers.
- Place ring gear on ring assembly and engage with pinion gears.



4. Attach Spider Assembly to Ring Assembly with three locknuts and torque to 15 ft/lbs. Fig. 9.



D. Replacement of Bronze Bearings to Spider Assembly

Place the Spider in press and install the long 1801460 bearing. Bearing should be pressed into the bore $.598 \pm .001$ inches from the end of the hub. A special pressing tool must be made for this operation in order to obtain the required dimension. Illustration 1, Step 1.

Insert the 1801461 Snap Ring and press the short 1801459 bearing flush with the spider hub. The snap ring must be free to expand and not pressed tight between the two bearings. Illustration 1, Step 2.

NOTE: If pressing equipment is not available, it is recommended that the entire Spider and Bearing Assembly be replaced rather than attempting to replace the bearings.

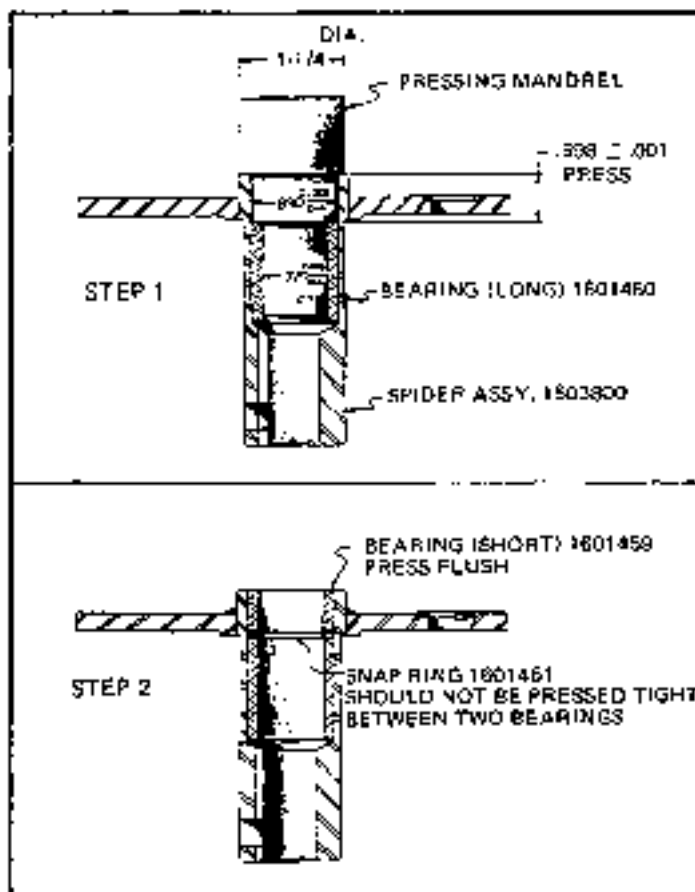

5. Apply Shell Durina EP #1 grease liberally to the area around the gears and in the bore of the spider. Fig. 10.

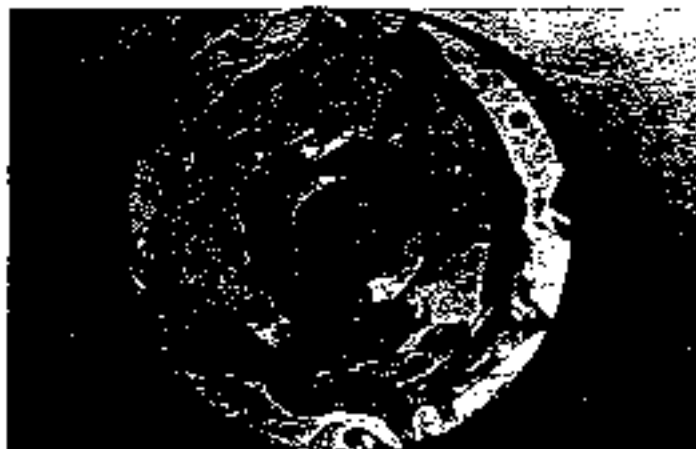

6. Place one gasket on the R.H. Cover Assembly and press the Spider Assembly on to the Cover Assembly until the snap ring engages the first detent groove. Fig. 11.
7. Clamp the Cover Assembly in a vise and align the holes. Place the second gasket on the Ring Gear and align holes.



8. Place shift ring on the ring gear and align holes. Fig. 12.



E. Installation of Needle Bearing in Pulley and Gear Assembly

9. Place pulley on a solid surface or in a press and install one needle bearing with marked end out. Press bearing flush with surface of pulley hub. Turn pulley over and press the second bearing flush with hub. Marked end of bearing should also be out. Illustration 2.
10. Work grease into needles of both bearings and fill the area between the bearings with grease to the approximate thickness of the bearings. Fig. 13.
11. With Pulley Assembly resting on bench, place the L.H. Cover Assembly on the pulley and position the third gasket on the cover. Fig. 13.

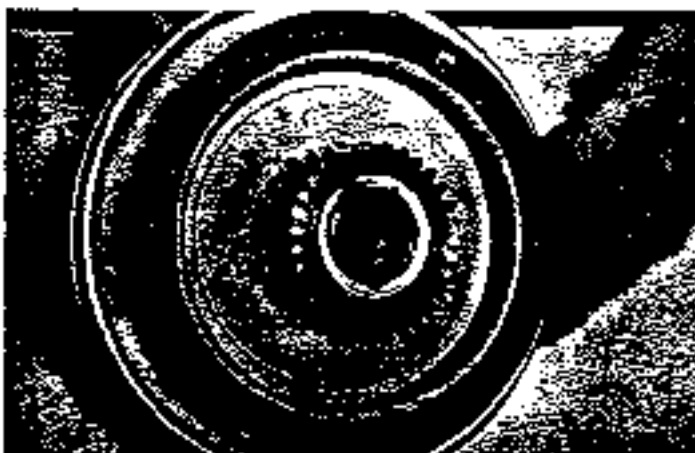
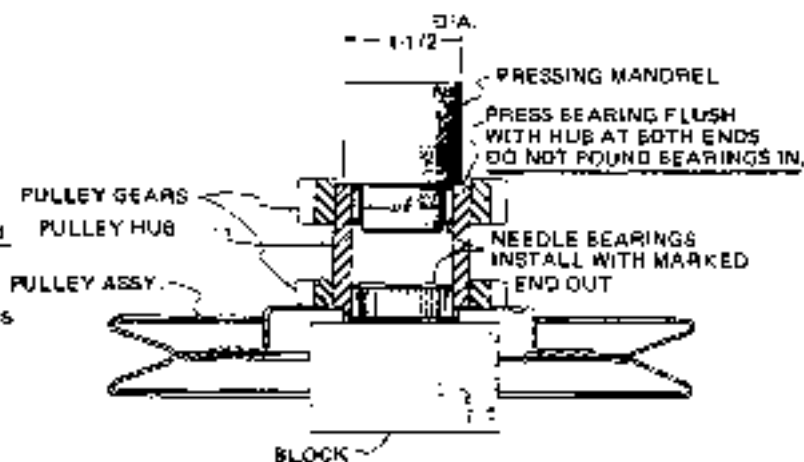

12. Holding the Pulley and L.H. Cover Assemblies together, place on top of Shift Ring. Carefully align pulley gears with pinions in the Spider Assembly. Align holes in cover before engaging gear teeth. Fig. 14.
13. Install six capscrews with heads toward pulley. Assemble nuts to screws and turn finger tight but do not tighten. Holding Cover Assemblies, turn the pulley in both directions to center gears. Tighten nuts to 75 inch pounds in 180° sequence.

NOTE: If pulley seems locked and will not turn, the Spider Assembly may have slipped out of low detent. If this has occurred, the unit will have to be disassembled and step six repeated.

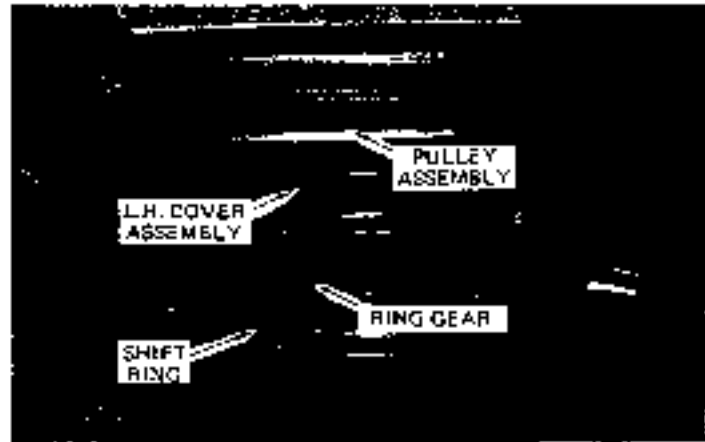

14. If pulley turns freely and no binding exists, the set collar may be installed. Turn pulley until one hole in the hub aligns with the keyway in the spider shaft. Place the set collar over the shaft with the setscrews angled toward the pulley hole. Turn the long setscrew until end just protrudes into hole in shaft. Turn pulley until hole in pulley hub lines up with the short setscrew in collar. Tighten this setscrew securely to the shaft. Fig. 15.



15. Install on tractor, reversing steps 1-5 in Disassembly (Section A).

VARIABLE SPEED PULLEY
For E-112 Tractor

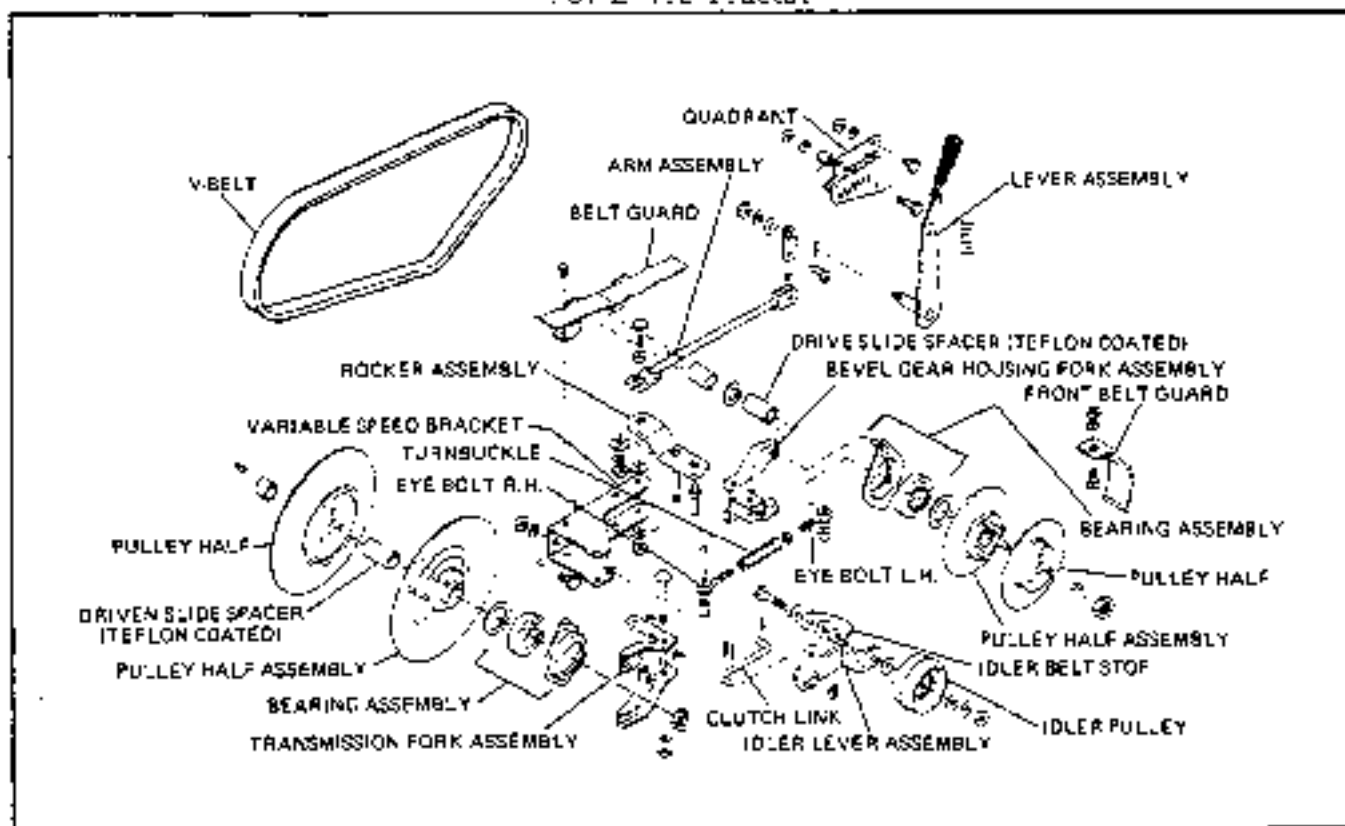

FIGURE 1

DISASSEMBLY

The variable speed pulley is designed to provide easy access to all parts. To replace the bearing assembly or bushing in the pulleys, observe the following steps:

1. Remove the drive belt.
2. Remove the locknut on the pulley shaft.
3. On the rear pulley it will be necessary to remove transmission fork assembly.
4. Remove pulley halves and bearing assembly.
5. Inspect and replace teflon bushing and bearing assembly if necessary.

NOTE: The bearing and bearing retainer are serviced assembled with "Loctite".

6. Clean all parts, lightly oil the teflon bushing and reassemble pulleys.
7. Do not exceed 50 lb. torque on the locknut when reassembling. Over-torquing will cause the pulley halves to bind.

TURNBUCKLE REMOVAL

A. Remove the 1/8" nut and bolt from the arm and rocker assembly, reference letter "A", Fig. 2.

B. Remove the locknuts, reference letter "B", Fig. 2 and lift out bolt and rocker assembly.

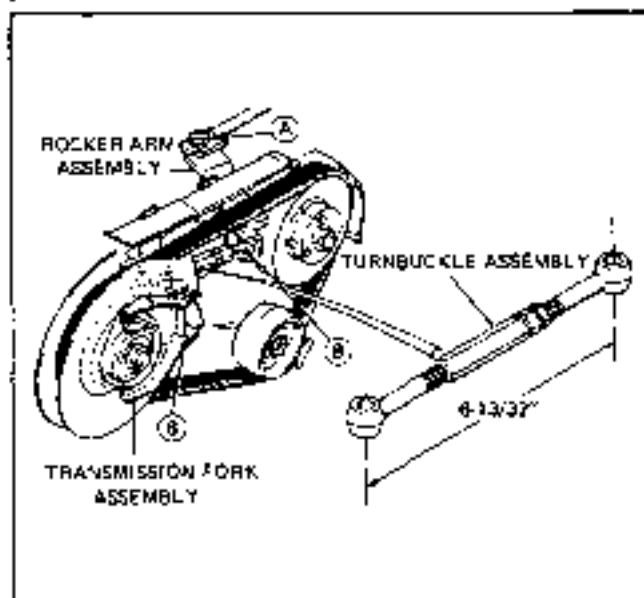

FIGURE 2

C. Remove the transmission fork assembly and turnbuckle as follows:

1. Adjust the turnbuckle so that holes of the eyebolts are parallel. The distance between the holes is 6-13/32". Note that one end of the turnbuckle body is grooved to identify the R.H. thread end. The grooved end should be

placed forward when assembling in the tractor. Assemble both eyebolts with the same length of threads engaged in the turnbuckle. (See Fig. 2.)

2. Install the turnbuckle assembly.

IMPORTANT: After tightening the locknuts, reference letter "B", Fig. 2, insure that there is free movement of the fork assemblies.

CLUTCH - BRAKE & BELT ADJUSTMENT

The variable speed mechanism is adjusted at the factory under "no load" conditions. In most instances, this adjustment should provide satisfactory operation. If, however, under load or after the "break-in" period, erratic or improper operation is noted, follow the procedures outlined below to make necessary adjustments.

NOTE: All adjustments require the variable speed lever to be placed in the "High" or the "Low" position. Carefully observe which position the variable speed lever should be placed in before making each adjustment. **DO NOT ATTEMPT TO MOVE VARIABLE SPEED LEVER WHEN ENGINE IS NOT RUNNING OR WHEN CLUTCH PEDAL IS DEPRESSED.**

CHECK THE FOLLOWING ASSEMBLY ADJUSTMENTS

1. Check bolt and locknut holding arm assembly to rocker arm. (See No. 1.) (This adjustment to be made in "High" speed position.)
2. Check for proper clearance on front belt guard. (See No. 2.) (This adjustment to be made in "High" speed position.)
3. Check for proper clearance of idler pulley belt stop. (See No. 3.) (This adjustment to be made in "Low" speed position.)
4. Check for proper clearance between the nuts on clutch rod and the set collar. (See No. 4.) (This adjustment to be made in the "Low" speed position.)
5. With variable speed lever in the "Low" speed position, the belt in the large, rear pulley should be approximately 1/8" below the top of pulley. (See No. 5.)
6. Check brake adjustment. (See No. 6.) (This adjustment to be made in "Low" speed position.)

OPERATING INSTRUCTIONS

1. Do not attempt to move variable speed lever when tractor engine is not running or when clutch pedal is depressed.
2. Insure that parking brake is fully disengaged before placing tractor in motion.
3. Occasionally check and remove foreign objects and debris from variable speed belt and pulleys.

GEAR RANGE AND SPEED SELECTIONS

1. To obtain the most desirable results with various attachments on the Sovereign Tractor, it is recommended the tractor engine be operated at 3/4 to full throttle setting.
2. When operating attachments such as the 10" Plow, Spring Tooth Harrow or Cultivator, which place a heavy draw-bar load on the tractor, it is preferable to operate tractor in I or II speed rather than III speed, low range.

BELT SLIPPAGE

If belt slippage is noted, check the following:

1. Check to insure the parking brake is fully disengaged.
2. Check No. 4 under Assembly Adjustments.
3. Check No. 5 under Assembly Adjustments.
4. On early production models the spring is normally in the top hole. If less spring tension is desired, move spring to next lowest hole or pivot lever assembly. Less tension can be used when mowing on level terrain and if clutch pedal is found to be uncomfortably hard for the operator to depress. (See Fig. 3.) Greater belt tension is necessary to prevent variable speed belt from slipping when tractor and attachment are under heavy load. A slight chattering of the variable speed belt on the pulleys will be noticeable until the belt loses its stickiness and becomes smooth.

On later production models no further spring adjustment is necessary.

LUBRICATION

If sliding pulley halves stick, lubricate bushing on which pulley rides tightly with a few drops of oil. Excessive lubrication will tend to collect dirt and dust and tend to hamper operation. Also lubricate all clutch and brake lever pivot points and all places where pull rods or links join levers.

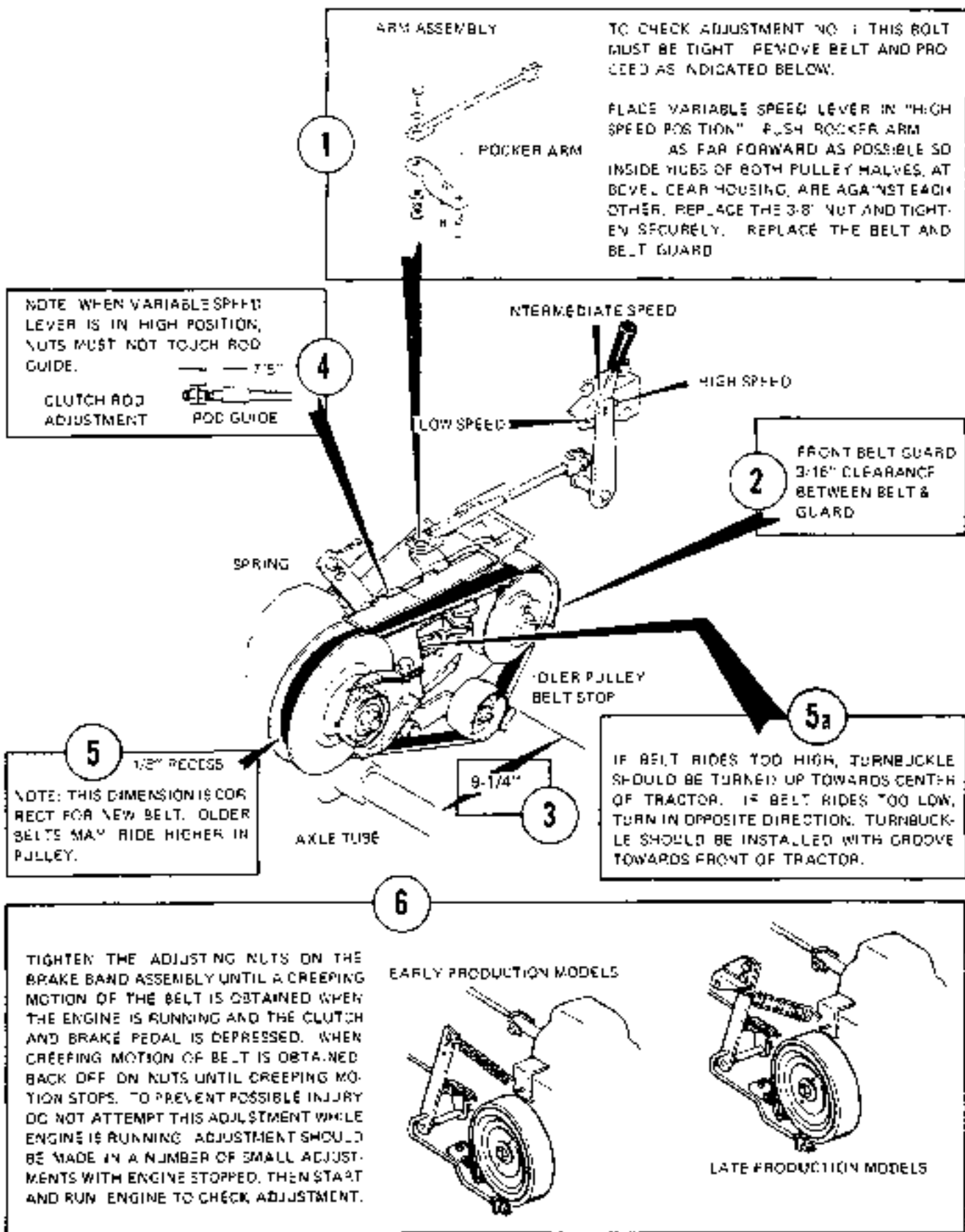

FIGURE 3

INDEX

WIRING DIAGRAM	
B-SERIES LIGHTING CIRCUIT	F-1
B-10 & Big TEN ELECTRIC	F-1
STATER & GENERATOR	
B-1 ELECTRIC STATER & GENERATOR	F-2
B-1, B-10, Big TEN LIGHTING CIRCUIT	F-2
B-10, B-12 LIGHTING CIRCUIT	F-3
B-10, Big TEN FRONT LIGHTS	F-3
B-1, FRONT LIGHTS	F-4
B-1, B-10, Big TEN REAR LIGHTS	F-4
B-110, B-112, 11B-112 WIRING DIAGRAM	
KEY & PUSH BUTTON START	F-5
B-208 WIRING DIAGRAM,	F-6
B-207, B-208, B-210, B-212, HB-212 WIRING DIAGRAM	F-6

F



THIS PAGE INTENTIONALLY BLANK

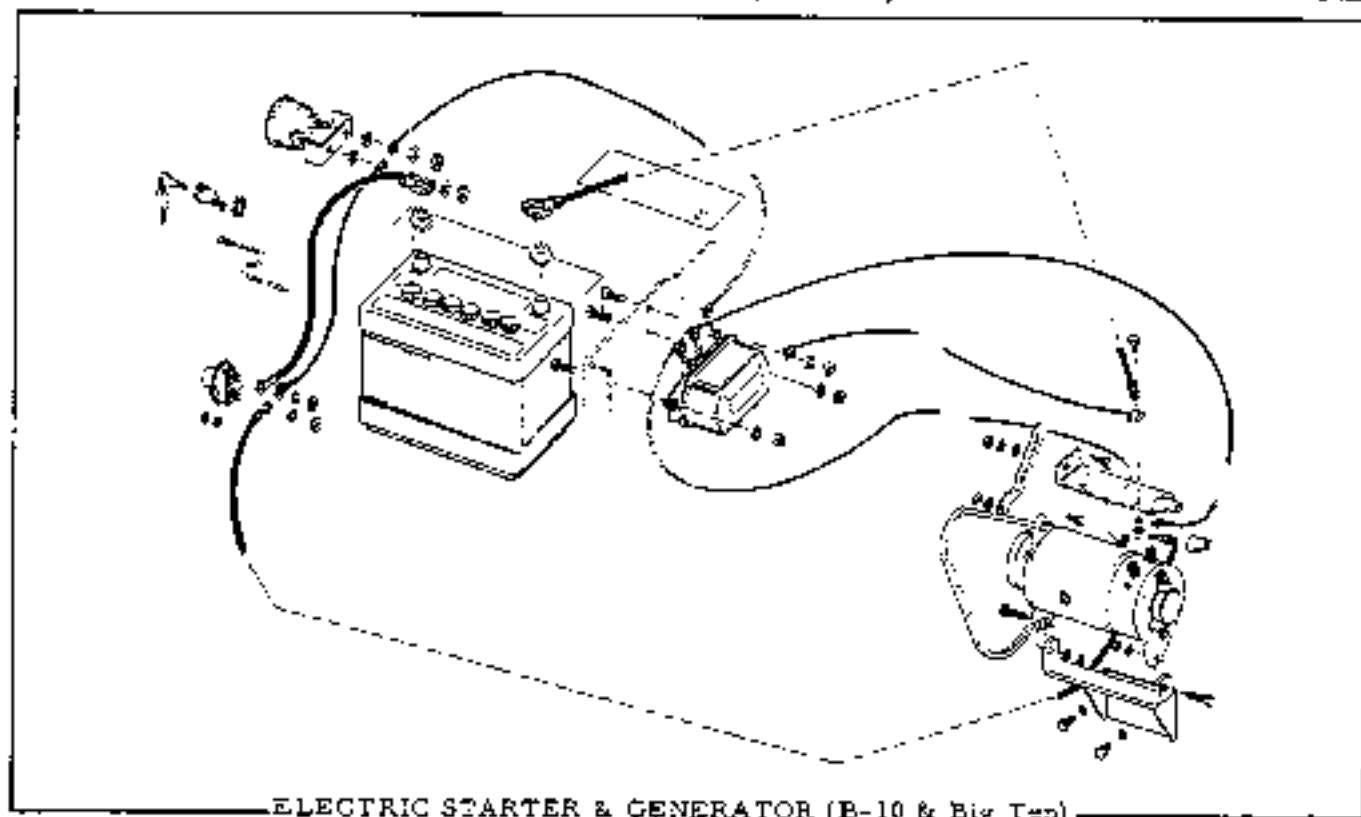
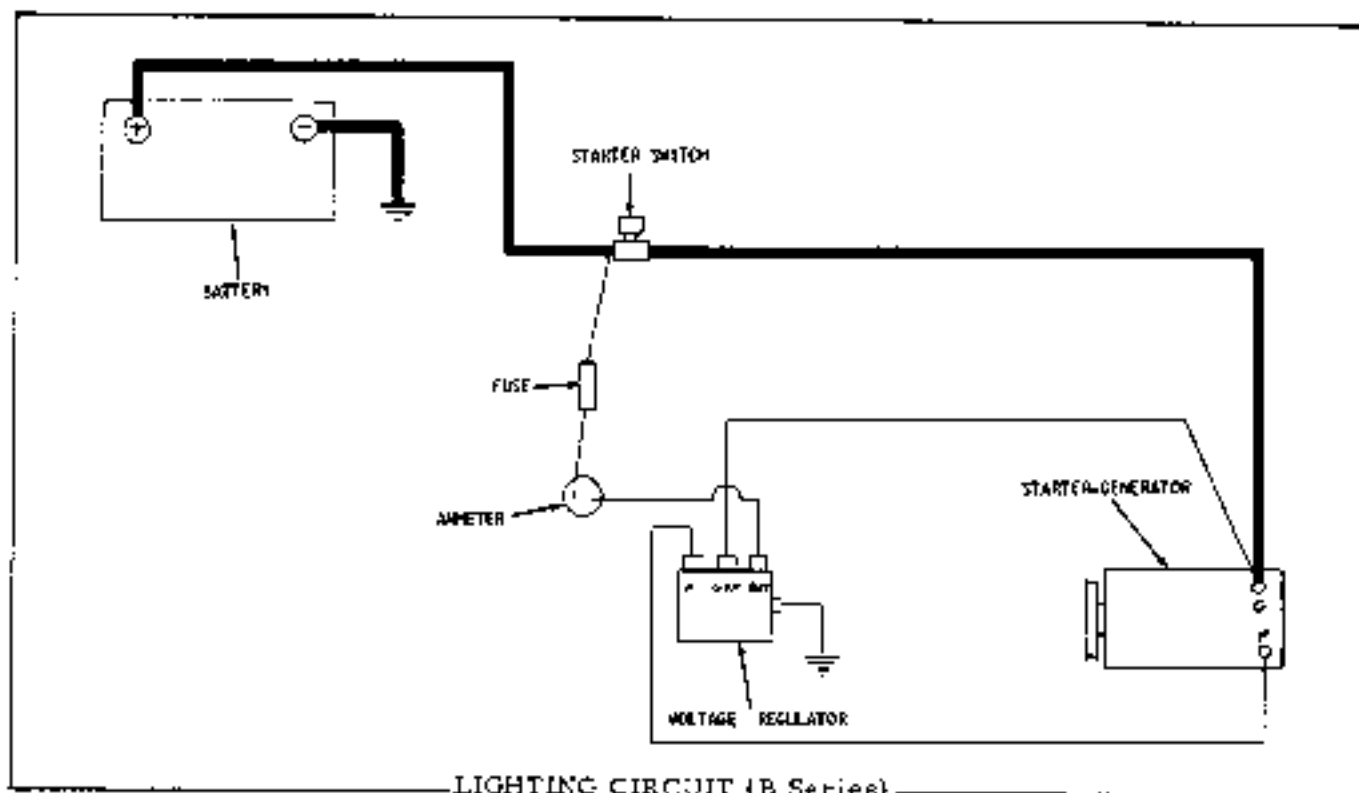

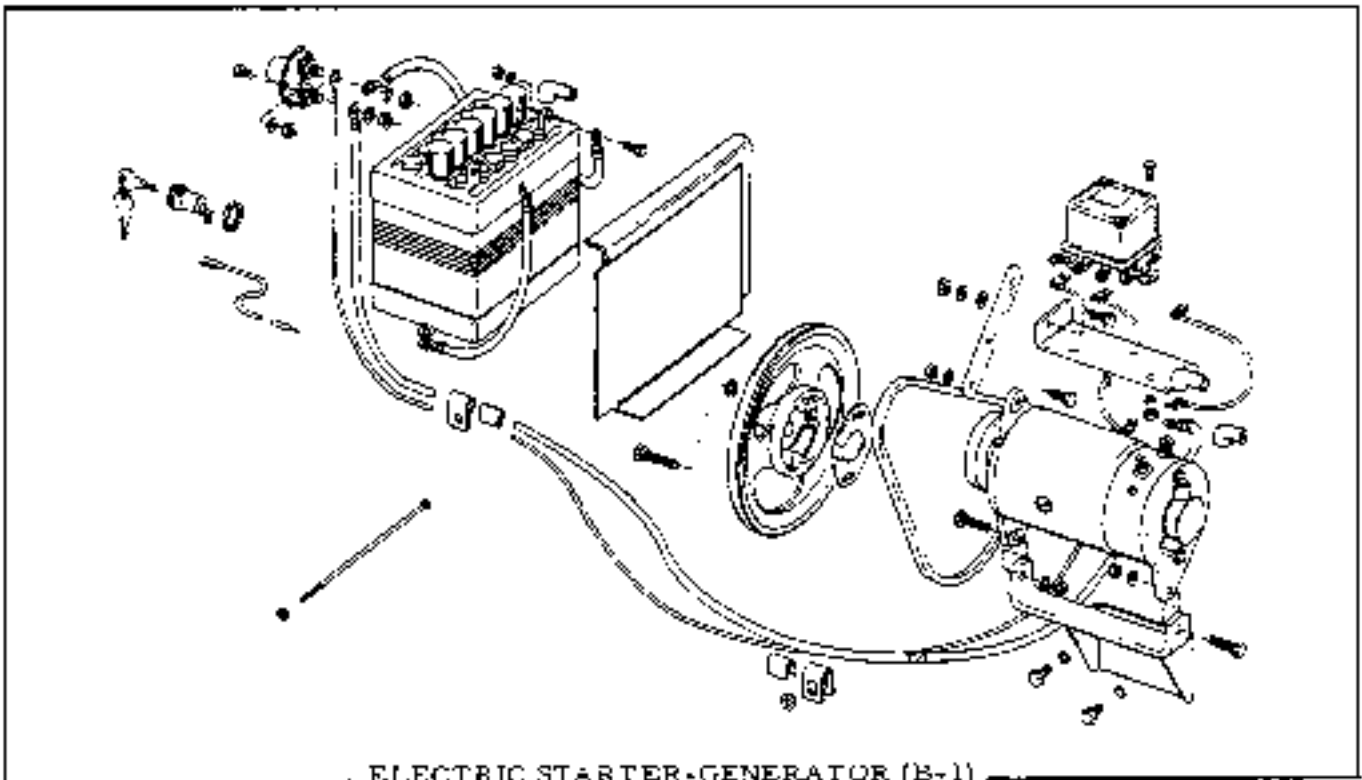

ELECTRIC STARTER-GENERATOR (B-1)

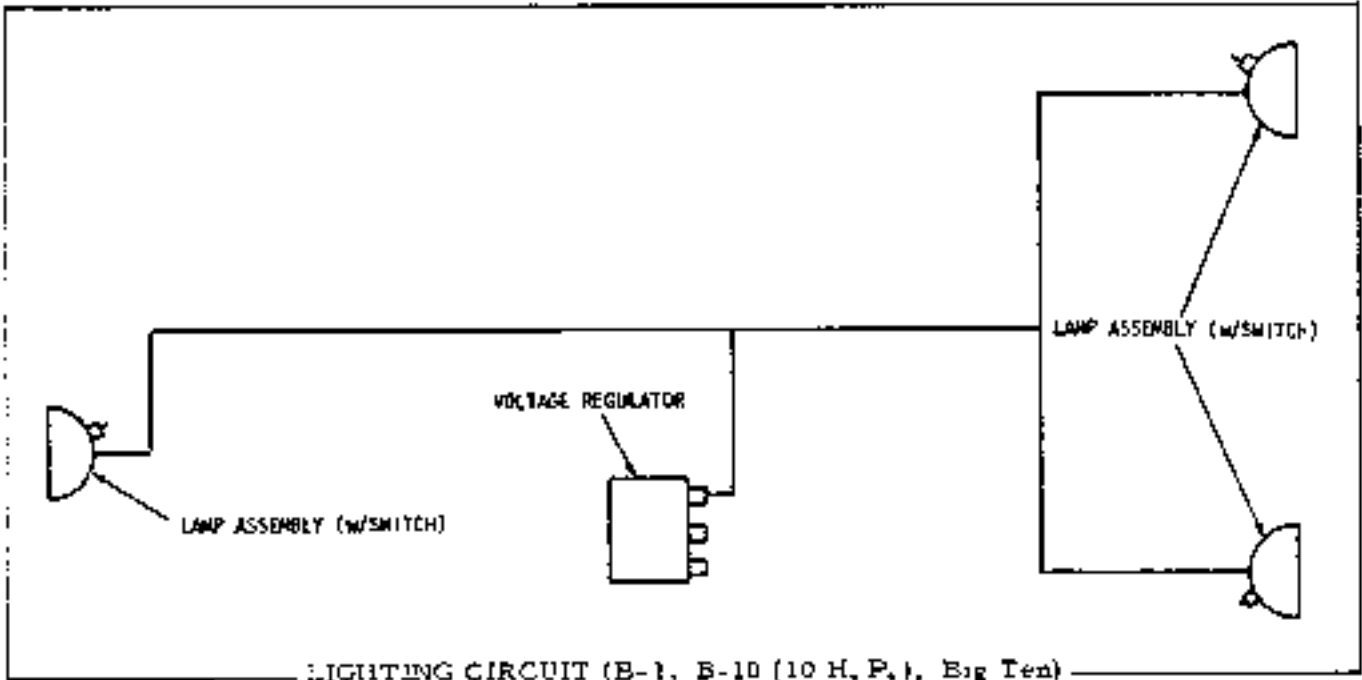

LIGHTING CIRCUIT (B-1, B-10 (10 H. P.), Big Ten)

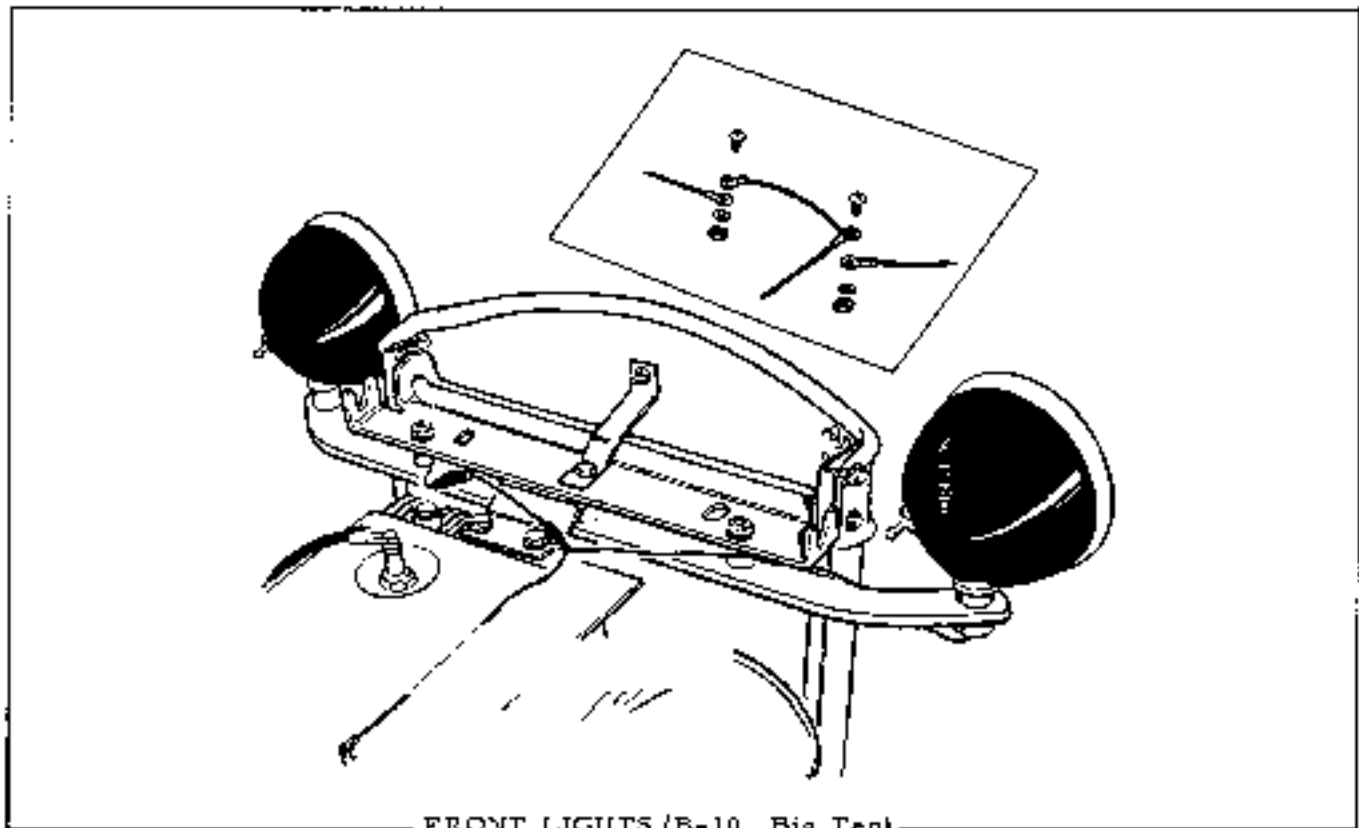
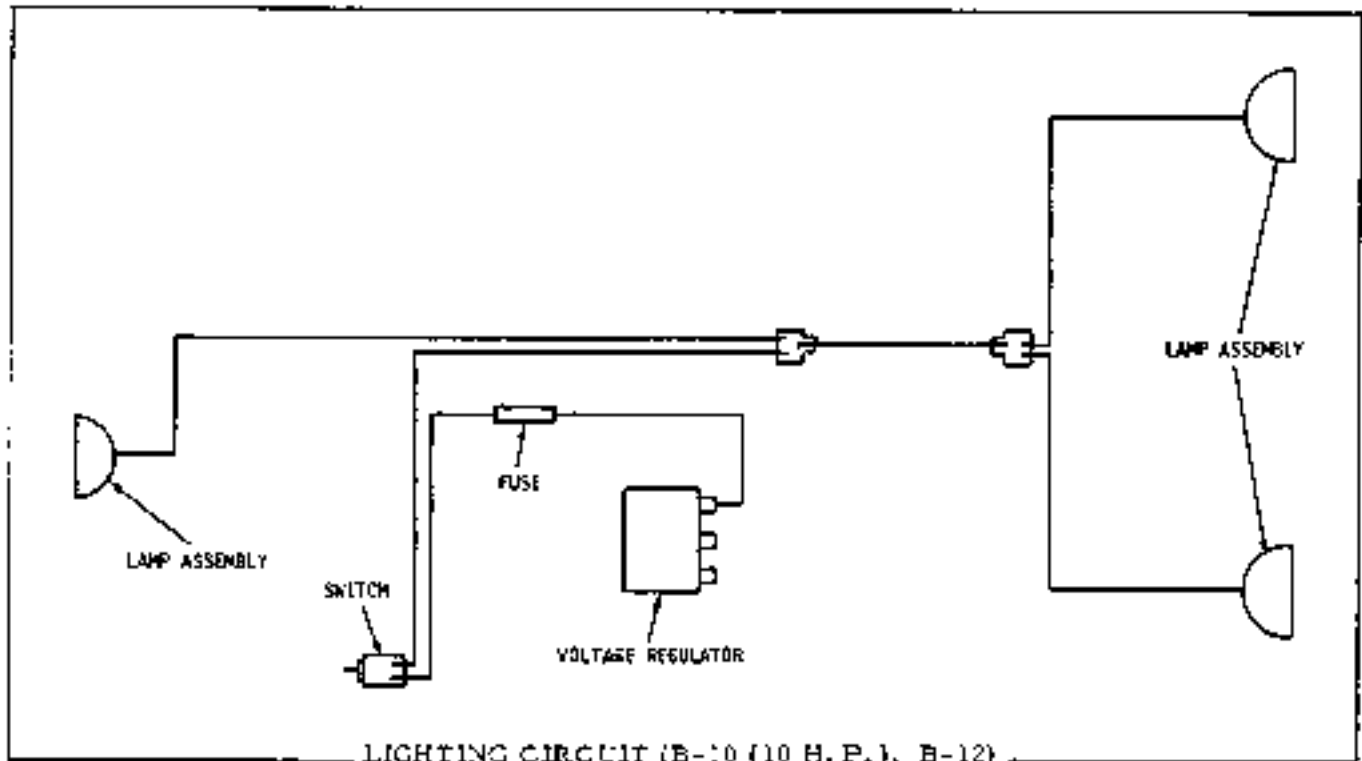

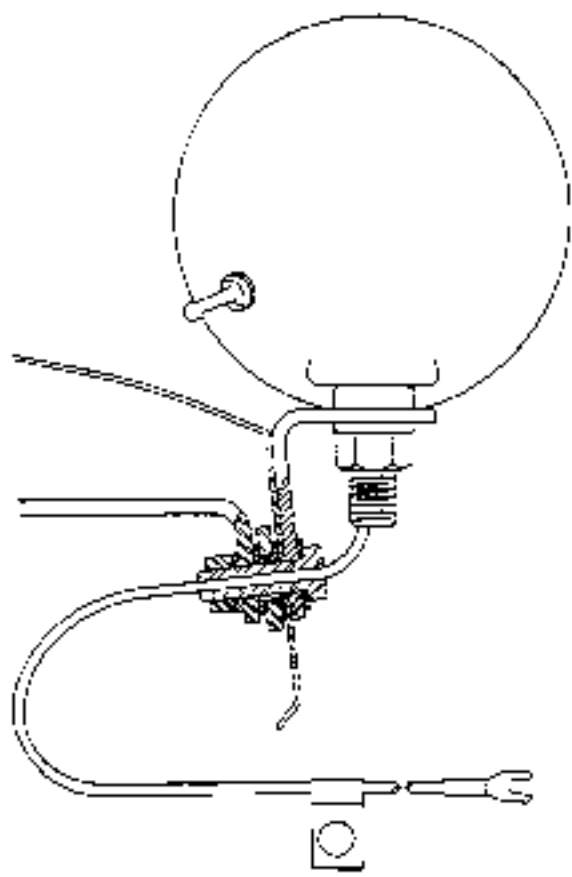

ELECTRIC LIGHT (Front) (B-1)

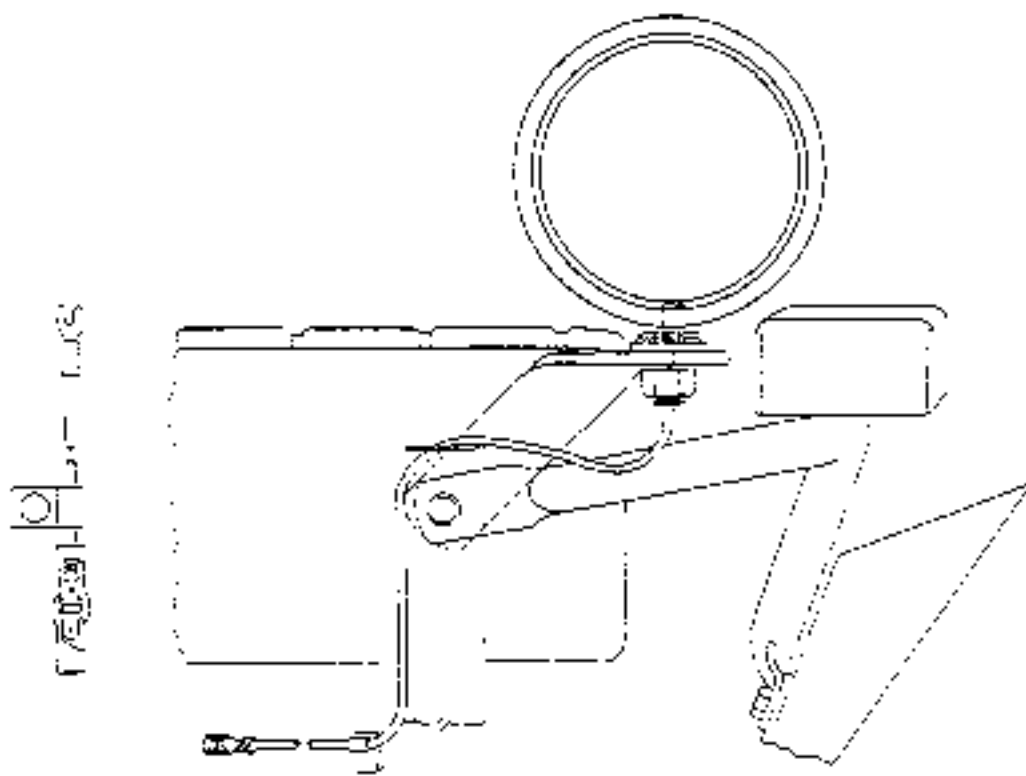

ELECTRIC LIGHT (Rear) (B-1, B-10, Big Ten)

WIRING DIAGRAM
MODEL B-110, B-112, HB-112

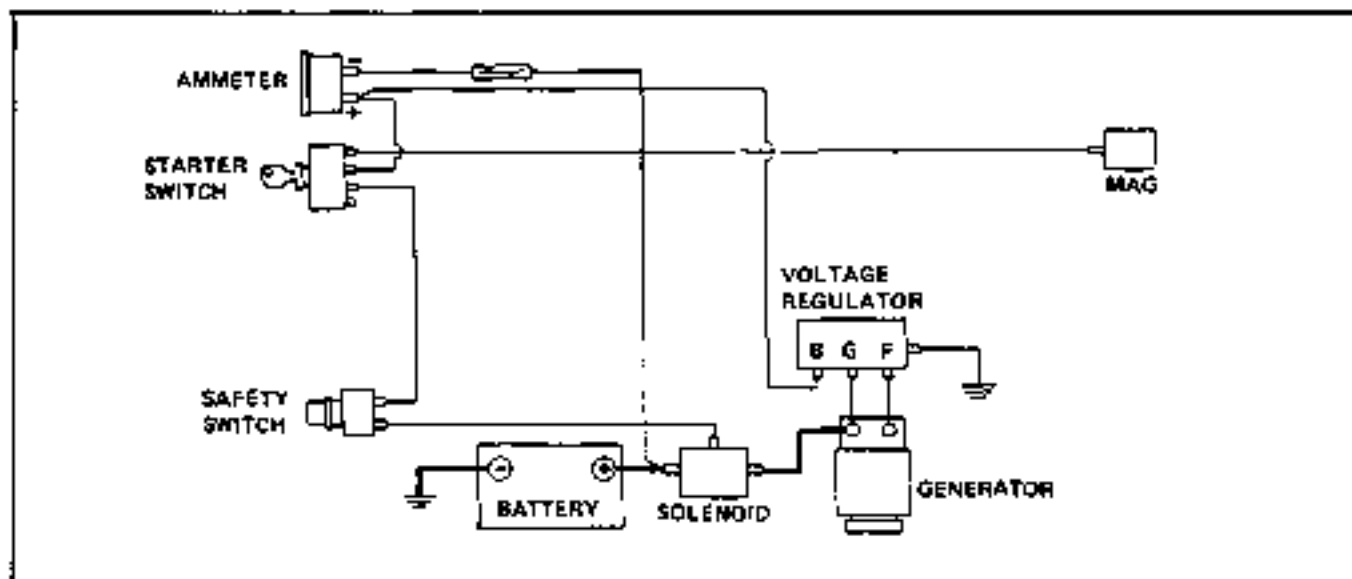

KEY START MODELS

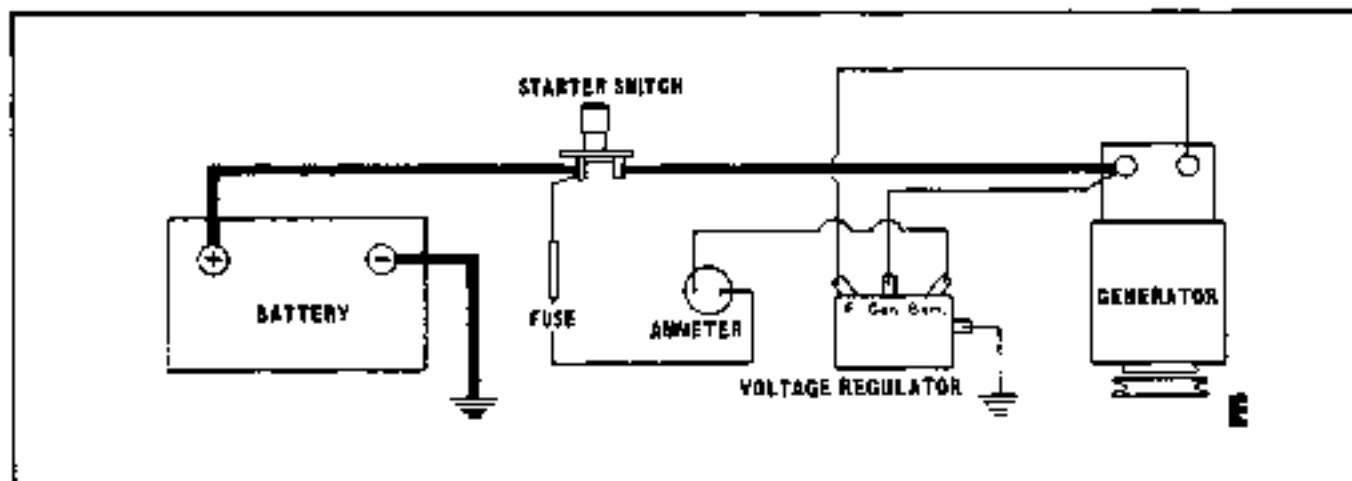

PUSH-BUTTON START MODELS

WIRING DIAGRAM
B-206

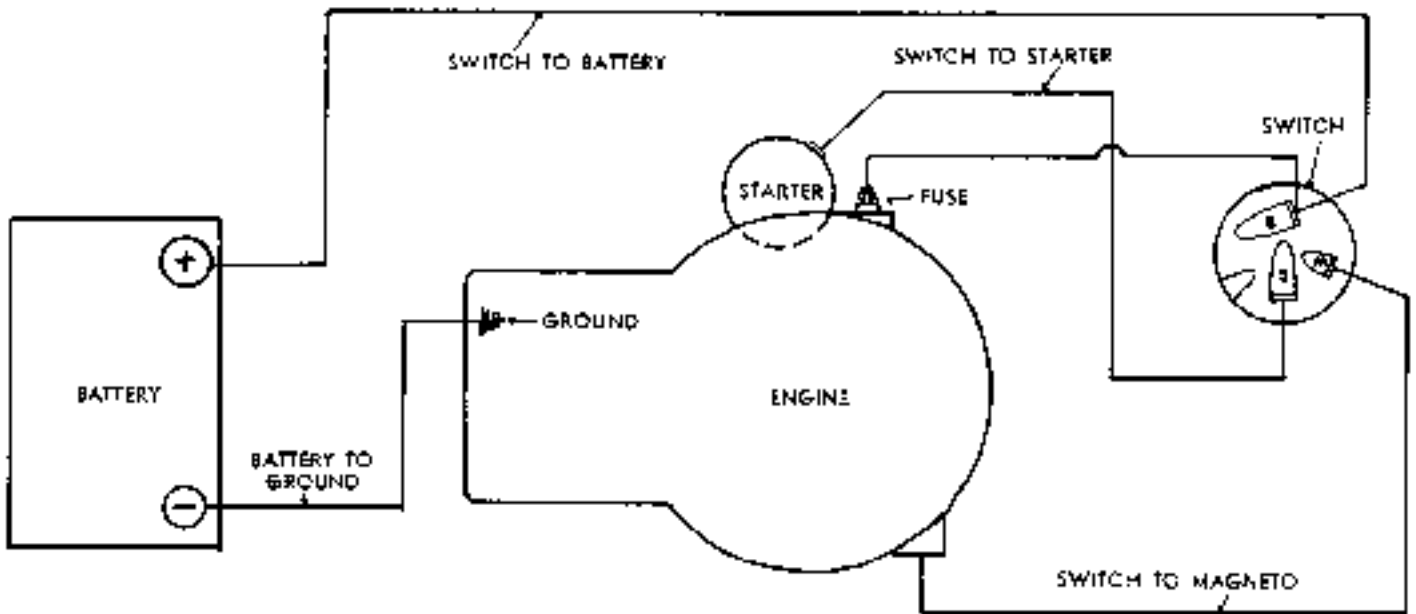

WIRING DIAGRAM
B-207, B-208, B-210, B-212, HB-212

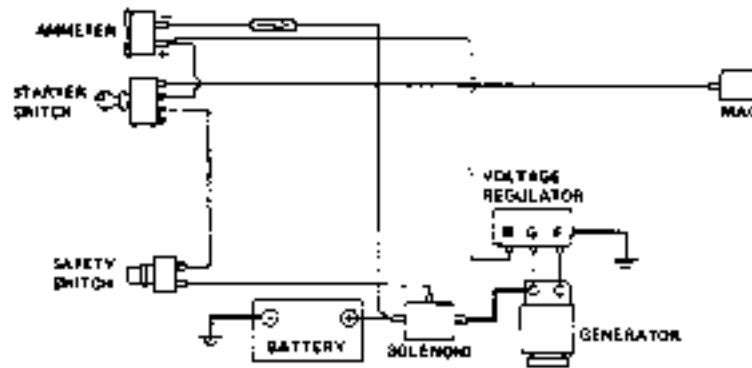

KEY START MODELS

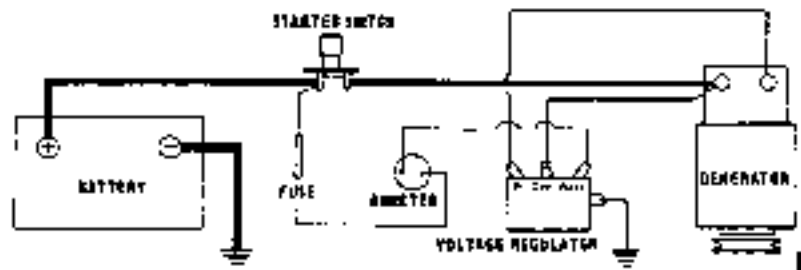

PUSH-BUTTON START MODELS

B - SERIES ATTACHMENTS

INDEX

CENTER P.T.O.	A
HI-LOW RANGE	B
ROTARY MOWERS	C
REEL MOWERS	D
SICKLE BAR MOWER	E
ROTARY TILLER	F
SNOW THROWER	G
GRADER BLADES	H
HITCH ADAPTER	I
PLOW - 10'	J
DISC HARROW, 8-12'	K
SPRING TOOTH HARROW & CULTIVATOR	L
LAWN ROLLER	M
MOBILE GENERATOR	N
SUMMER CAB	O
VACUUM COLLECTOR & TRAILER FRAME	P
FORK LIFT & LOADER	Q
L-12 LOADER	R

G



THIS PAGE INTENTIONALLY BLANK

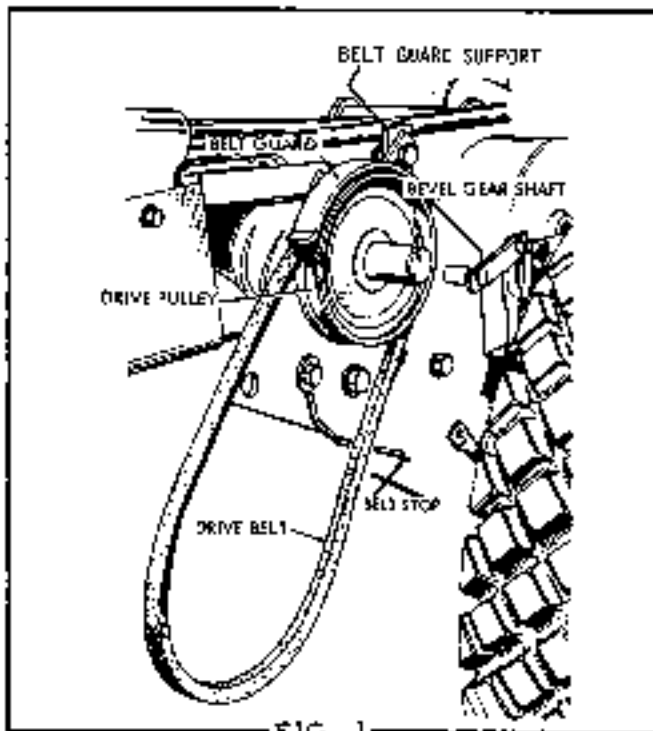

FIG. 1

POWER TAKE-OFF KIT

For operation of Rotary Mower and Sickle bar attachments, a power take-off attachment is required. This consists of the power take-off assembly, "V" pulley for bevel gear shaft, drive belt, belt guard and belt stop packaged in one carton.

For ease of attachment follow the steps outlined.

1. Install belt stop (2025718)
2. Mount belt guard support to inside surface of side plate nearest drive pulley.
3. Holding the P.T.O. assembly in L.H. (Fig. 2) position the tube of the drive bracket assembly between the bevel gear housing side plates. Align the holes in the side plates with the hole in drive bracket assembly tube and insert pivot pin through holes in side plates and drive bracket assembly tube, so the cotter key hole in pin lines up at "A". (Fig. 3)
4. Remove hex capscrew "D" from frame of tractor and mount bracket in place on left lever quadrant (Fig. 4). Position the pivot bar assembly flush against bottom of left quadrant and reinstall the hex capscrew and tighten securely. Check alignment of drive pulley on bevel gear shaft, driven pulley of P.T.O. and idler pulley and adjust driving pulley if necessary.
5. Mount drive pulley to shaft of bevel gear assembly (Fig. 1). Hub of drive pulley is to face

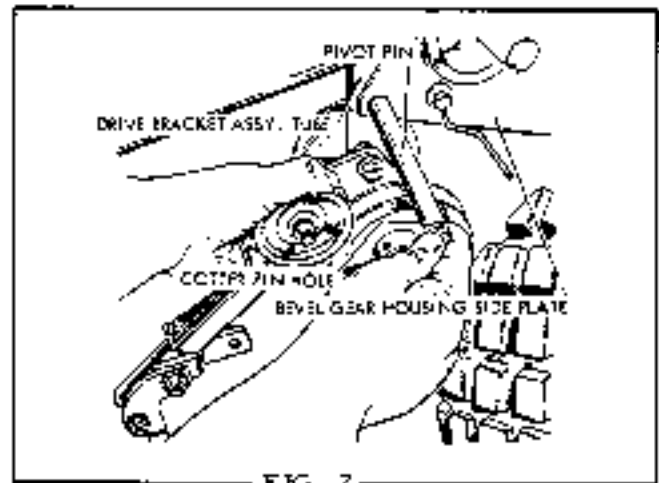

FIG. 2

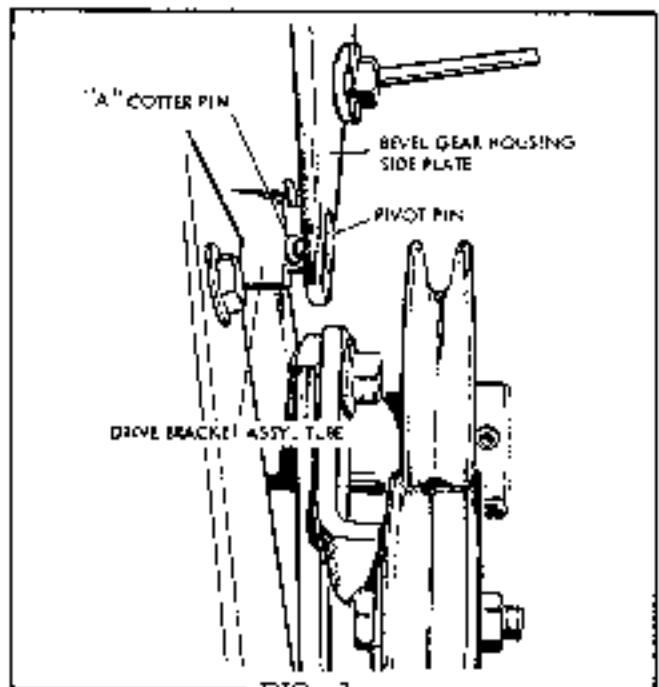

FIG. 3

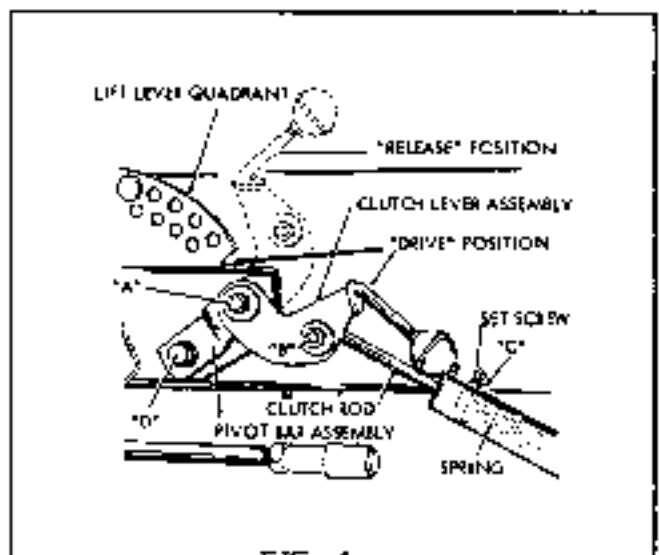

FIG. 4

inward. Place the drive on drive pulley and P.T.O. pulley. Align belt and secure in place with key and setscrew.

6. Attach the belt guard to the guard support as shown in Fig. 3. Allow approximately $3/16$ " clearance between belt and guard.

7. Remove front hex capcrew from pull bar and replace with stud #2026431 provided, short end inserted. Slip on handle assembly and tighten with locknut provided to allow free handle movement. Mount bolt in place on drive pulley (Fig. 5) and attach spring to hole provided in bottom of bracket assembly. Mount belt stop as shown with $3/8$ " bolt, flat washer, lockwasher and hex nut. When implement is attached to tractor and P.T.O. is engaged, $1/8$ " clearance between belt stop and back of belt is required.

LUBRICATION

The P.T.O. is lubricated by means of one grease fitting located on the bottom front of the drive bracket assembly. Occasionally apply grease by means of a standard grease gun loaded with automotive type grease. Be sure to wipe dirt and grit from grease fitting before applying grease gun. Lubricate all pivot points and idler pulley bearings with SAE 20 oil every few hours of operation.

OPERATION

Operation of the P.T.O. is controlled by movement of the clutch lever assembly. (See Fig. 4). When the clutch lever is in the forward raised position, the clutch rod releases the tension holding the idler pulley against the drive belt and power will not be transmitted to the driven pulley of the P.T.O. assembly. When the clutch lever is in the back, depressed position, the clutch rod applies tension to the idler pulley and as the idler pulley takes-up the slack in the drive belt, power is transmitted from the drive pulley on bevel gear box shaft to the driven pulley of the P.T.O. Fig. 4 shows clutch lever in drive position.

ADJUSTMENT

At points "A" and "B" of Fig. 4, check tightness

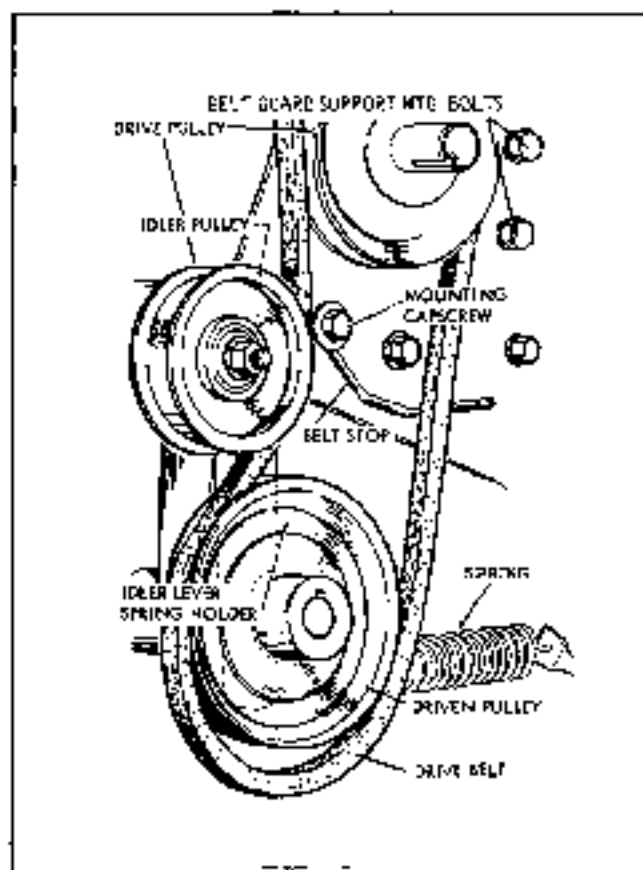

of hex nut to be sure that clutch lever assembly and clutch rod are free to pivot without binding.

Place clutch lever in "drive" position and observe clearance between collar "C" (Fig. 4) and end of bracket. When implement is attached to tractor, this clearance should normally be approximately $3/4$ " at this setting the idler pulley should be snug against the drive belt. If additional tension is required, release clutch lever and loosen setscrew on collar and slide collar farther back on clutch rod. Retighten setscrew in collar and put clutch lever in drive position. Recheck clearance. The tension of the idler pulley against the drive belt must be sufficient to operate whichever tractor attachment is being used. Any additional tension is unnecessary and will only cause premature failure of belts and idler pulley bearings.

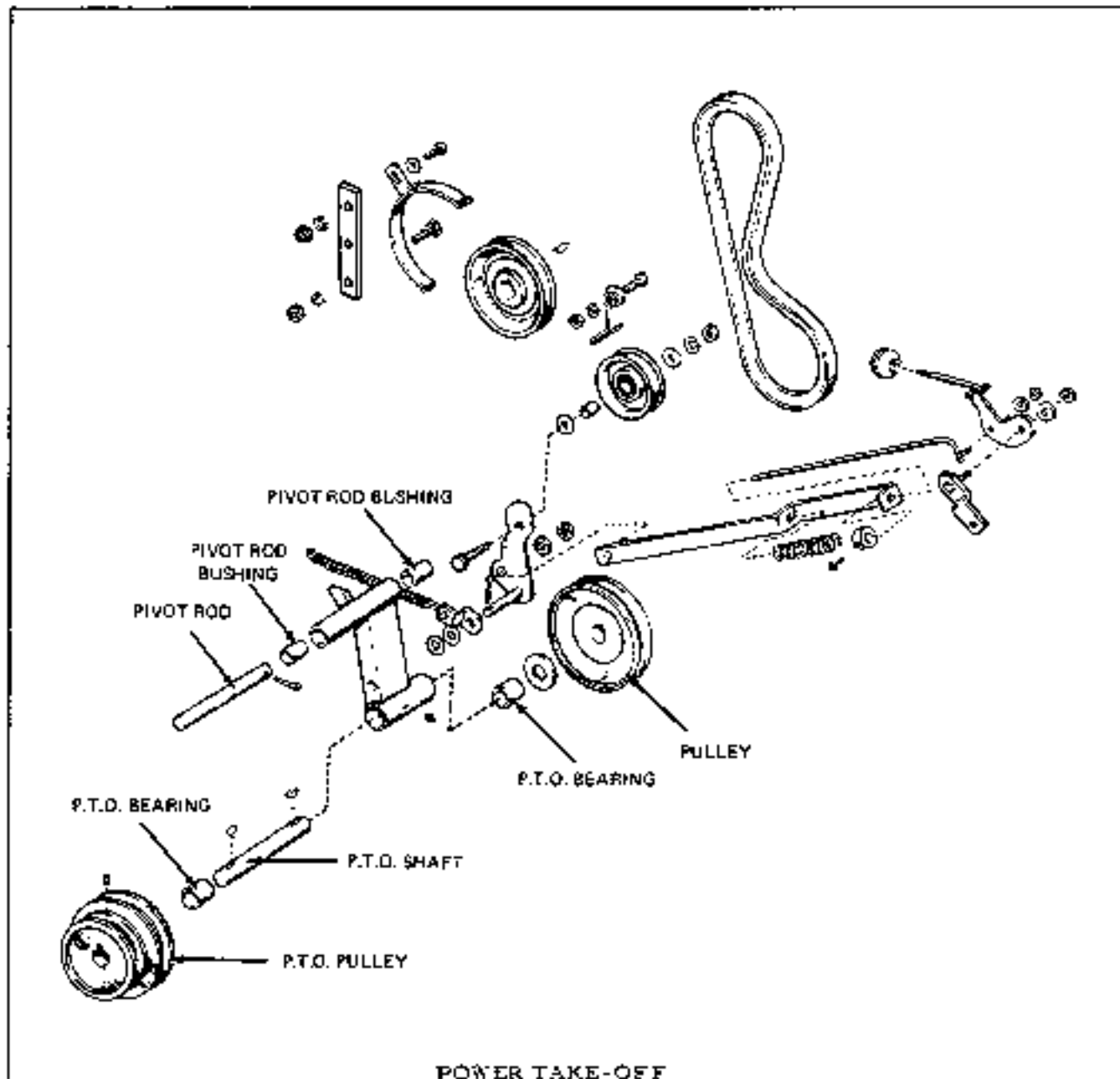

POWER TAKE-OFF
B-1 & B-10 Tractor

BUSHING REPLACEMENT

1. Remove pivot rod.
2. Drive out old bushings using driver large enough to contact bushing evenly.
3. Drive in new bushings. Be careful not to distort them.
4. Reinsert pivot rod.

BEARING REPLACEMENT

1. Remove pulleys from each end of P.T.O. shaft.

2. Remove P.T.O. shaft.
3. Drive out old bearings.
4. Insert new bearings being careful not to distort them.
5. Replace P.T.O. shaft.
6. Grease well with general purpose gun grease.
7. Replace pulleys back on shaft.

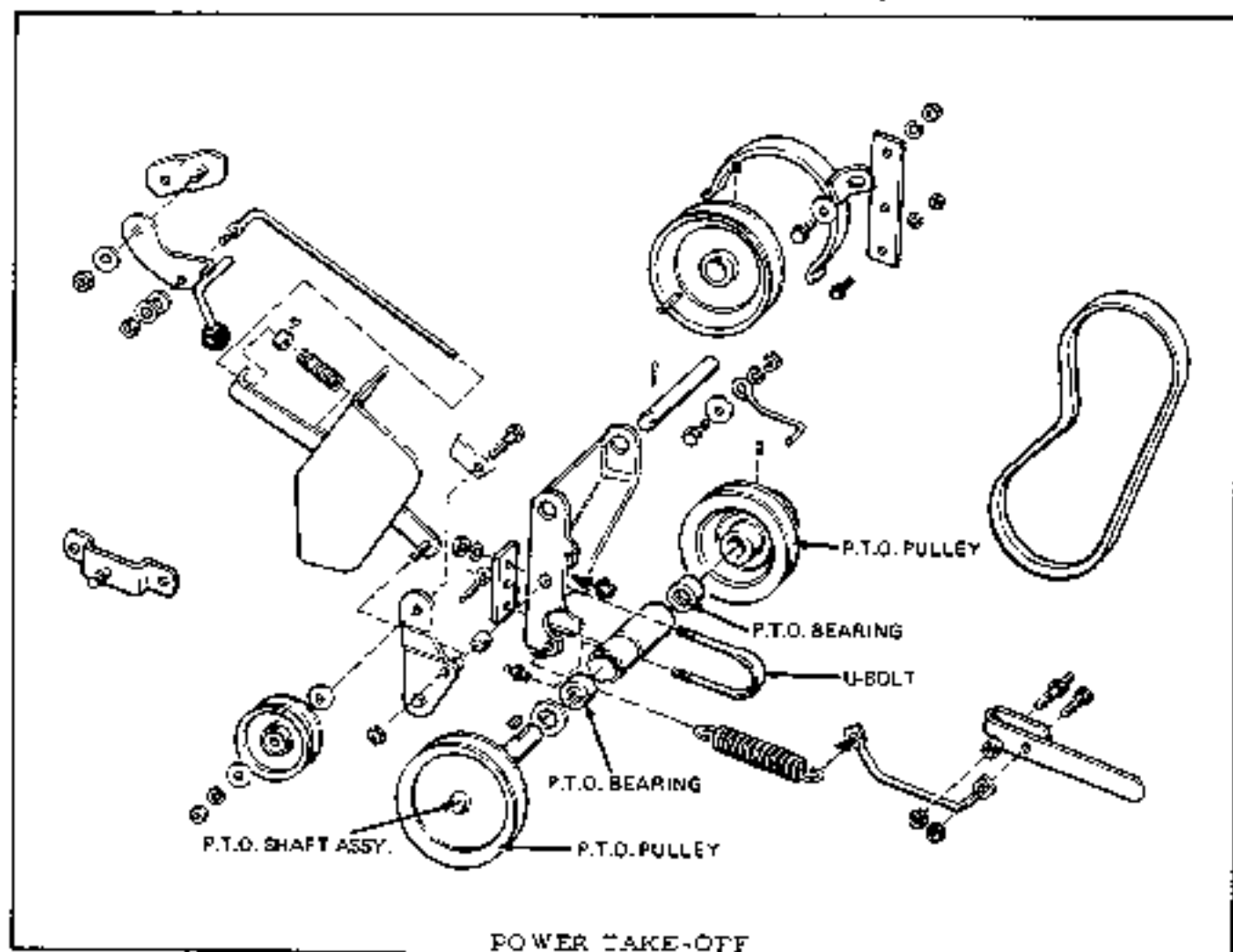

POWER TAKE-OFF
Big Ten Tractor (B-10, B-12)

BEARING REPLACEMENT

1. Remove U-bolt and remove bearing and pulley assembly from unit.
2. Remove P.T.O. pulley.
3. Remove P.T.O. shaft assembly.
4. Remove old bearings.
5. Install new bearings being careful not to distort them.
6. Reinstall P.T.O. shaft and P.T.O. pulley.
7. Grease well with general purpose gun grease.
8. Reinstall unit on tractor.

B-10 (9 H.P. - S/N 15001 - 31227) CENTER P.T.O. CATALOG NO. 2025045

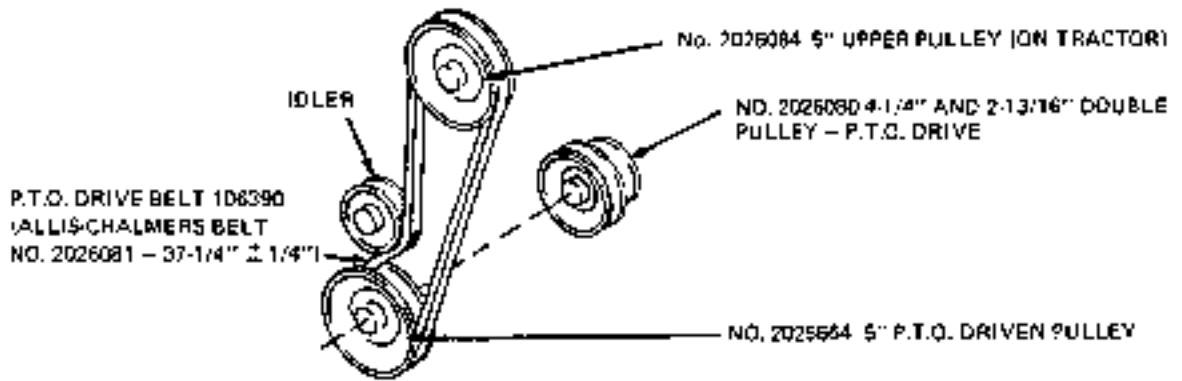

B-10 (9HP S/N 15001 - 31227) Center P.T.O.

BIG TEN, B-10 (10 H.P.) AND B-12 CENTER P.T.O. CATALOG NO. 2025062

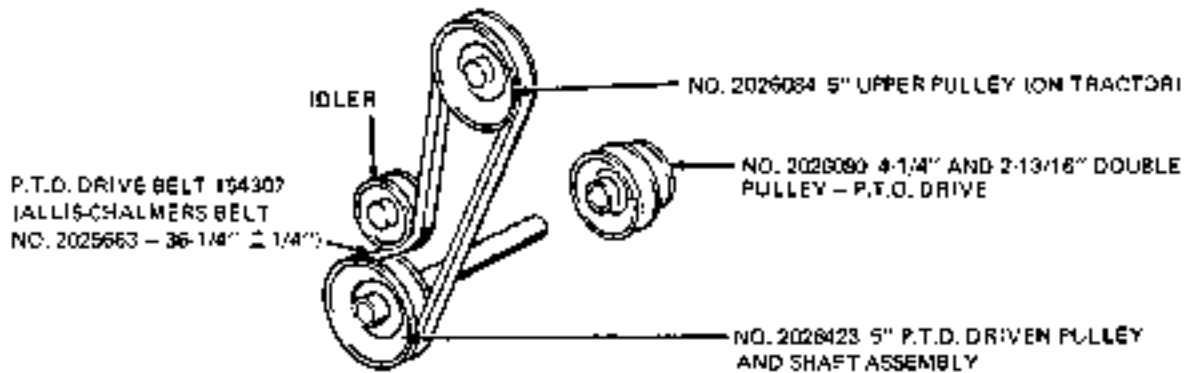

Big Ten, B-10 (10HP) And B-12 Center P.T.O.

This information shows each center P.T.O. package, pulley part numbers and diameters and

belt numbers and lengths. The belt lengths are then measured around the outer circumference.

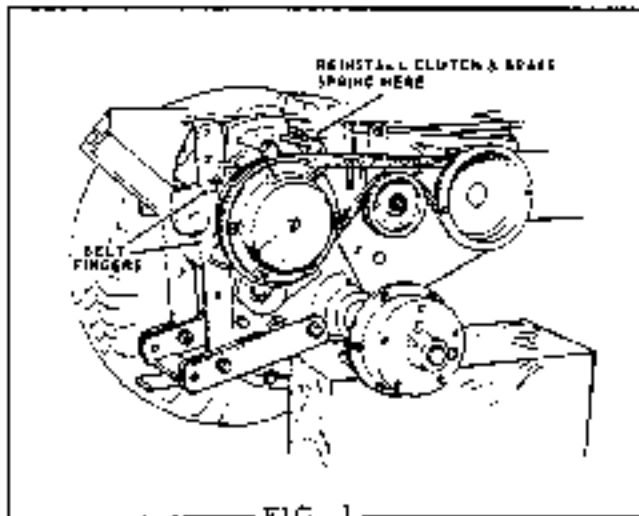

FIG. 1

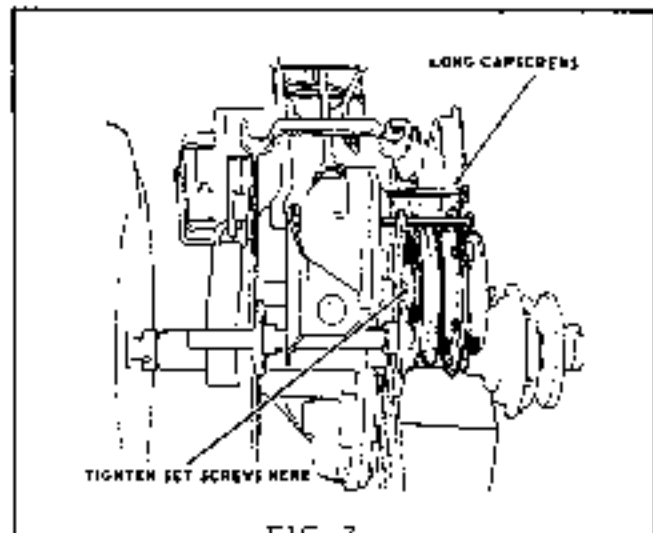

FIG. 2

ASSEMBLY AND INSTALLATION

1. Depress the clutch and brake pedal and apply the parking brake.
2. Remove the belt from the transmission pulley.
3. Remove the transmission pulley and key from the transmission shaft.
4. Place the drive belt around the transmission shaft close to the transmission case.
5. Install the two belt stop fingers as indicated in Fig. 1.
6. Install the two-speed pulley key in place in the transmission shaft.
7. Attach the two-speed pulley and gear case to the transmission shaft. Place the drive belt around the pulley and loosen the parking brake. Align the two-speed pulley with the idler pulley and the bevel gear housing pulley.
8. Tighten the setscrew on the key and then the other setscrew 90° away.
9. Remove the clutch hand brake spring from the cap screw on the transmission.
10. Remove this cap screw from the transmission case and also the other upper cap screw from the transmission case.
11. Insert the two long studs into the vacant cap screw holes in the upper end of the transmission case. Put the shifter handle assembly in place on these two long studs, making sure that the two pivots are properly positioned over the outer rim of the shift-ring. Refer to Fig. 5. Secure with hex nuts and lockwashers.

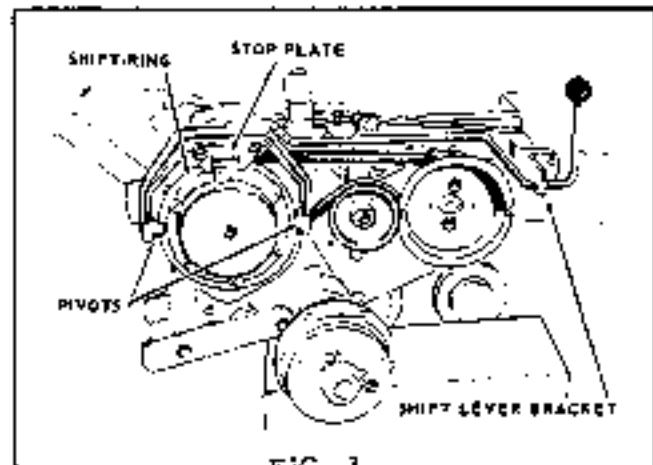
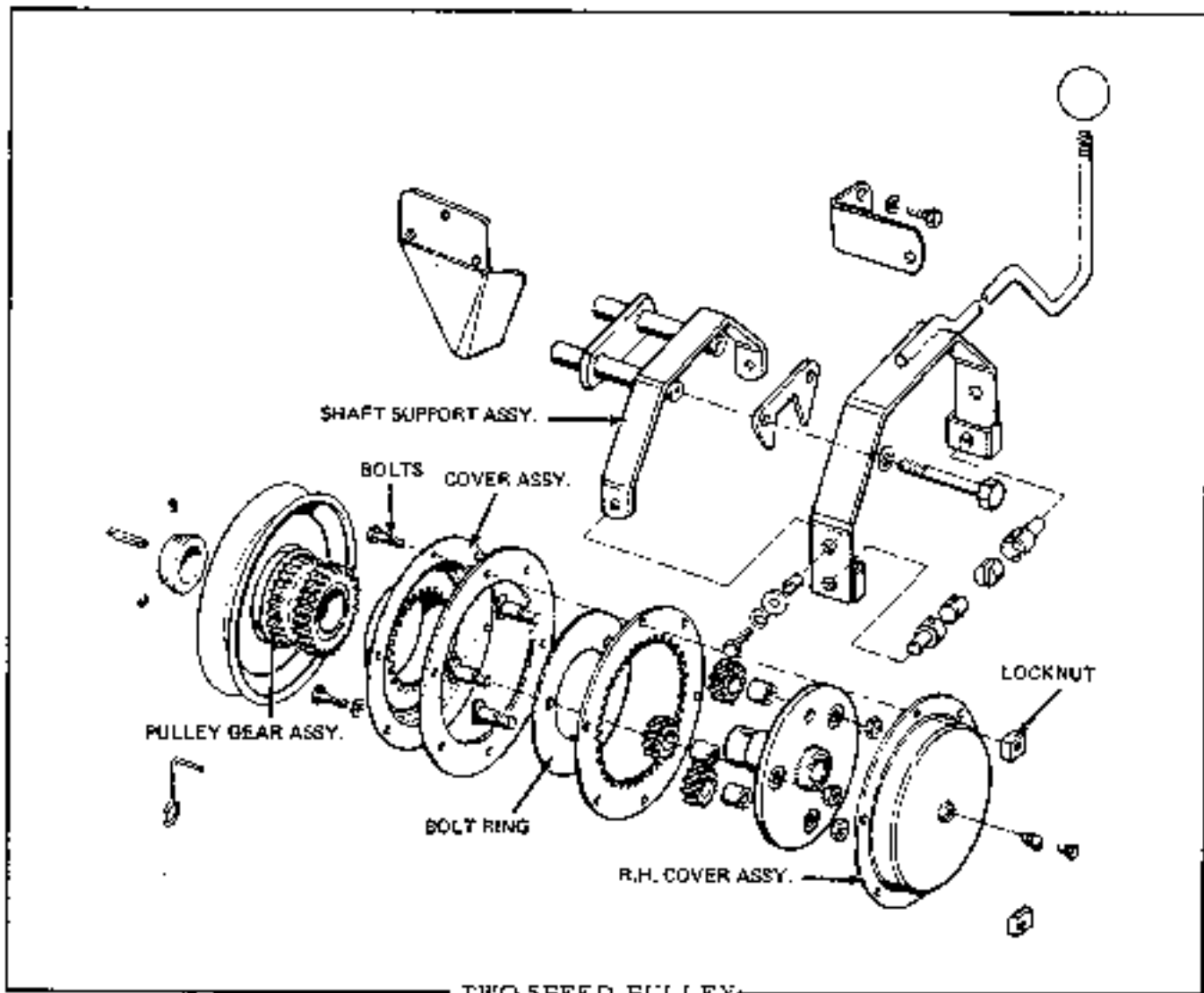

FIG. 3

12. Remove the cap screw from the right side of the tractor frame above the parking brake. Use this screw to attach the shift lever bracket as shown in Fig. 3. Align to permit proper movement of the shift lever and then tighten in place.
 13. Secure all bolts and nuts tightly. Check the clearance between the belt and the belt-stop fingers. When the belt is engaged, the clearance should be 1/16".
 14. Reinstall the clutch and brake spring on the bracket. (Refer to Fig. 1).
 15. Make sure that the stop plate (Fig. 3) is positioned next to the two-speed pulley gear case. Approximately 1/16" clearance is required between the stop plate end cover. With this minimum clearance the stop plate will lodge properly between the nuts.
- NOTE:** For purposes of illustration only, the tractor is shown with the wheel removed. It is not necessary to remove wheel to install the two-speed pulley assembly.



TWO-SPEED PULLEY

TWO-SPEED PULLEY

1. Remove unit from tractor by removing two capscrews from the shaft support assembly.
2. Remove the 6 bolts holding the cover assembly together.
3. Remove the pulley gear assembly.
4. Separate cover assembly, remove shift ring.
5. Remove ring gear and spider assembly from R.H. cover by inserting a shaft and gently tapping.
6. Disassemble pinions by removing locknut on ring pin bolts.

7. Clean and inspect for excessive wear.
8. Replace necessary parts.
9. Reassemble pinion and ring gear assembly and place in cover assembly.
10. Replace shift ring on cover.
11. Place cover assembly halves together, insert pulley gear assembly.
12. Bolt halves together alternating thick and thin attaching nuts.
13. Replace unit on tractor. Tightening securely setscrews holding unit to shaft.

ROTARY MOWER

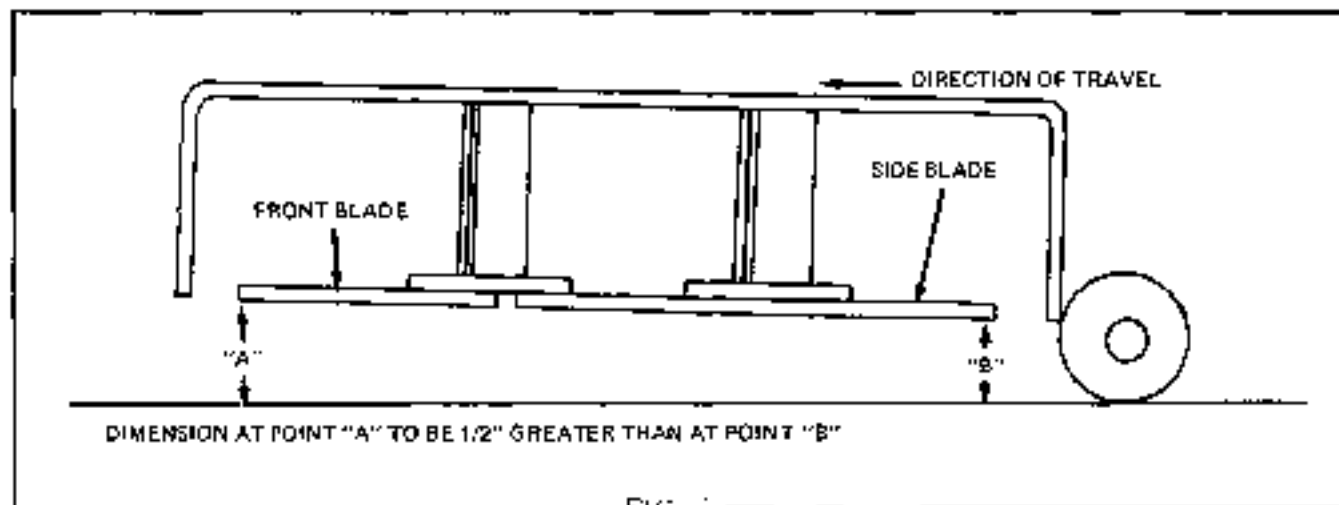

FIG. 1

ROTARY MOWER

ADJUSTMENT (Fig. 1)

1. Before the mower is attached to tractor, both clevises should be adjusted until the distance between the locknut and the head of the bolt is $1\frac{1}{2}$ ". This will position the front woker arms level or equi-distant from the floor.

2. Attach mower to tractor.

3. Lower mower to floor. Set the mower to the lowest cutting height by turning the adjusting screw handles to prevent possible distortion of lift linkage and to better stabilize cutting height adjustment. Counter-clockwise will lower the mower and clockwise will raise the mower. Rotate the center blade to the front and measure the distance from its front tip to the floor. Then rotate each of the side blades so the tip can be measured at the rear. The front blade should be adjusted $\frac{1}{2}$ " higher than the rear of the side blades. This can be done by removing the pins

and lengthening the clevises at the front mount to raise the front of the mower and shorten the front of the mower.

4. With the height adjusting screws and the mower at its lowest position, rotate the side blades and measure from the outside tips to the floor. This should measure the same on both sides. If one side is lower, the clevis on the front mount on that side should be lengthened slightly. With the adjustment properly made, it will aid the cutting height adjusting screws to keep the unit level.

5. Set the mower to the top of the cutting height adjustment. On the units with two adjusting screws at the roller, use caution and see that they hold the unit level. They must be adjusted the same amount of turns each time the cutting height is changed. Because of the linkage at the front mounting points, the mower will maintain the fore and aft adjustment. Start the mowing operation with a long or high stubble. Lower the mower evenly to the desired cut. If at first the cut is too high, the area can be removed.

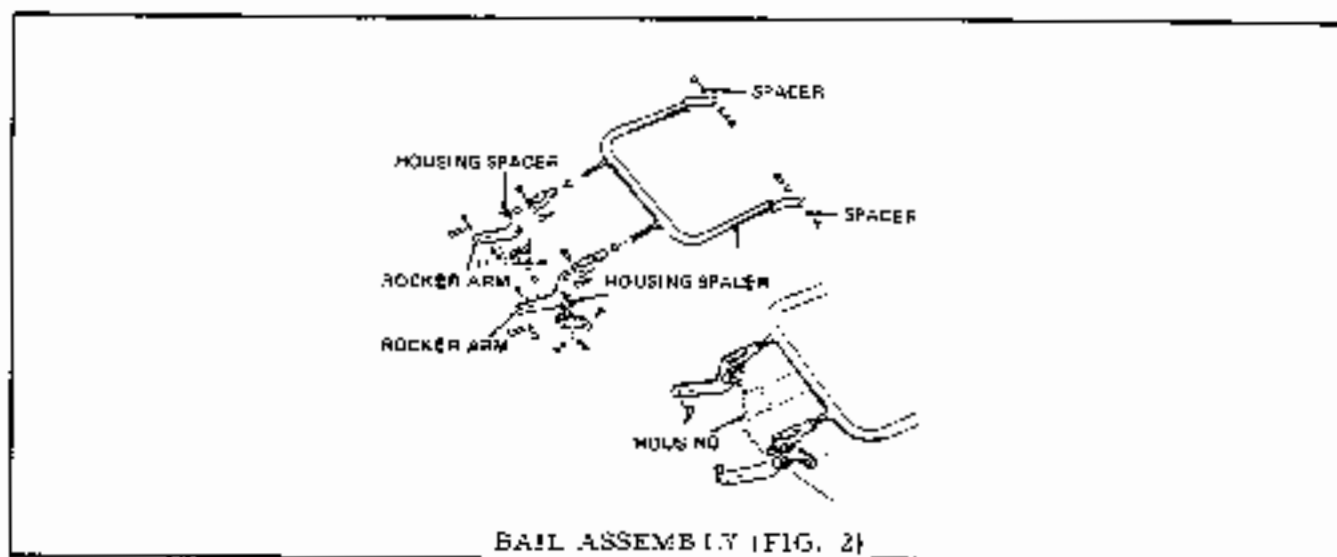

BAIL ASSEMBLY (FIG. 2)
42" Rotary Mower

The mower rocker arms have a spacer where they fasten to the housing. This as well as other

fastening locations may wear after prolonged usage. (See Fig. 2).

ROLLER MAINTENANCE

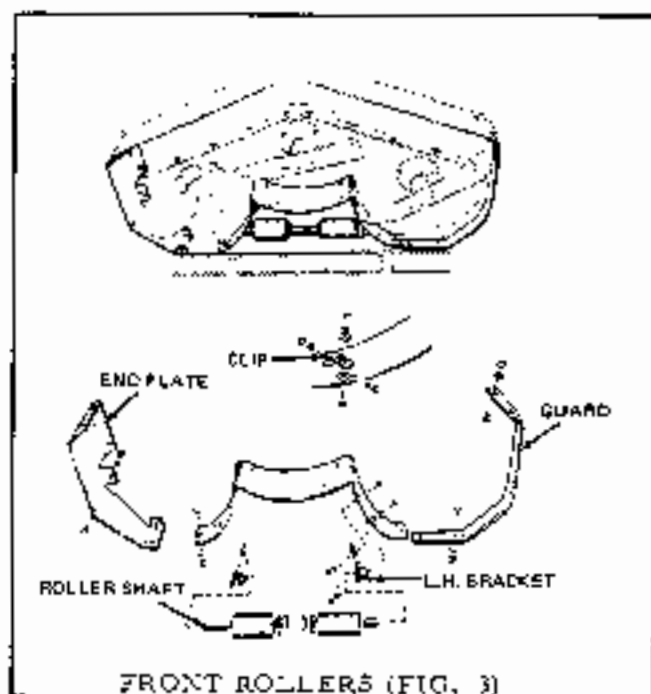

FRONT ROLLERS (FIG. 3)
1st Type w/ Bolted Housing

A. FRONT ROLLERS (Figs. 3 & 4)

1. Remove 2 cotter keys between rollers.
2. Slide shaft to the left. Remove R.H. roller.
3. Slide shaft to right. Remove L.H. roller.

1967 MODEL MOWER (w/ Nylon Inserts)

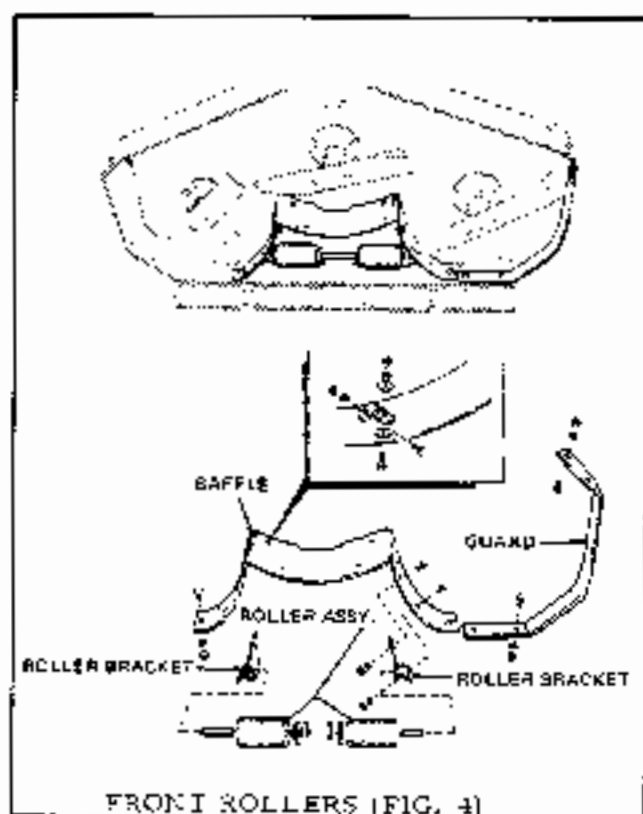

FRONT ROLLERS (FIG. 4)
2nd Type w/ Bolted Housing

1. Remove brackets and roller assembly from baffle.

2. Remove cotter keys from between rollers. Remove rollers. Shaft is welded into R. H. bracket.

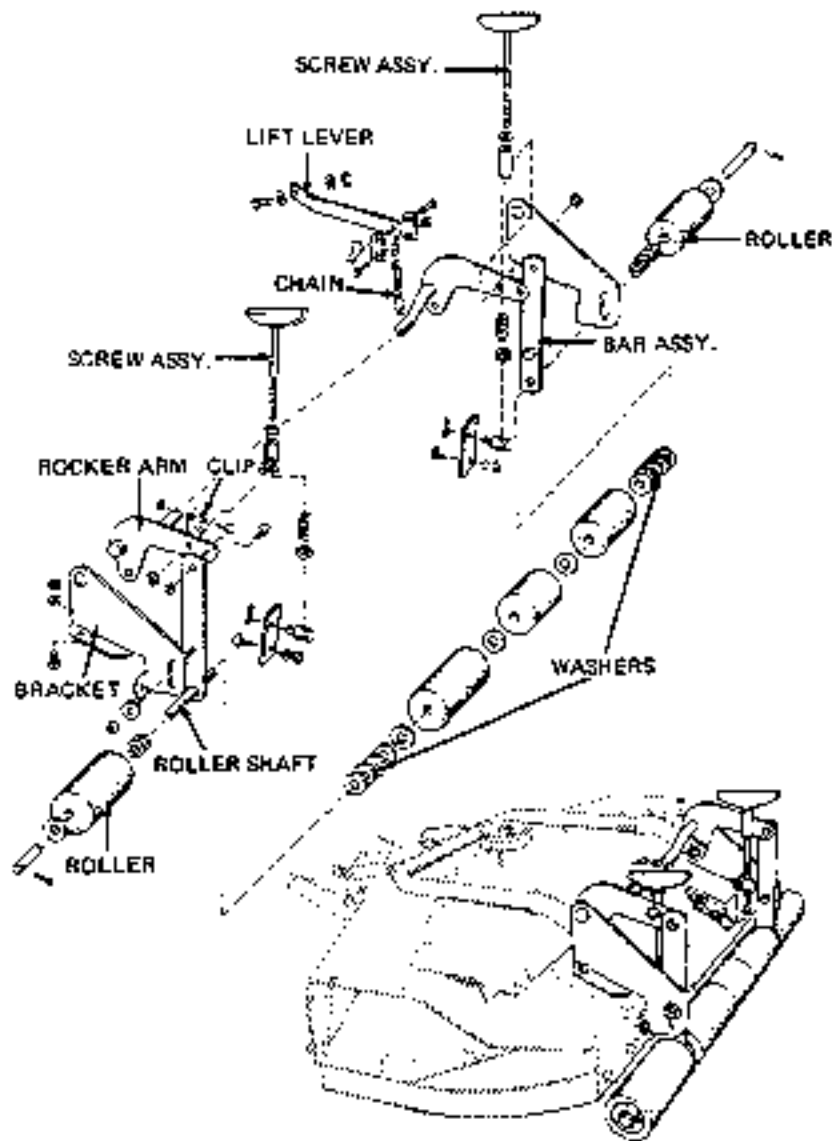

REAR ROLLER ASSEMBLY (FIG. 5)
42" Rotary Mower

B. REAR ROLLERS (Fig. 5)

1. Remove cotter keys from each end.
2. Remove washers and rollers from shaft. In later models, the shaft is welded in the lift bar on the right side. The lift bar must be removed along with the shaft.

ASSEMBLY PROCEDURE (Left to Right)

1. Cotter Key
2. One large Flat Washer
3. Large Roller
4. Three Small Washers
5. Lift Brace
6. Five Flat Washers
7. Large Roller

8. One Flat Washer
9. Small Roller
10. Flat Washer
11. Large Roller
12. Five Flat Washers
13. Lift Bar
14. Three Small Washers
15. Large Roller
16. One Flat Washer
17. One Cotter Key

The groups of 5 flatwashers are spacers. Some units may contain less washers.

The mower rollers should not require lubrication. However, if they are lubricated oil should not be used. Hydraulic brake fluid should be

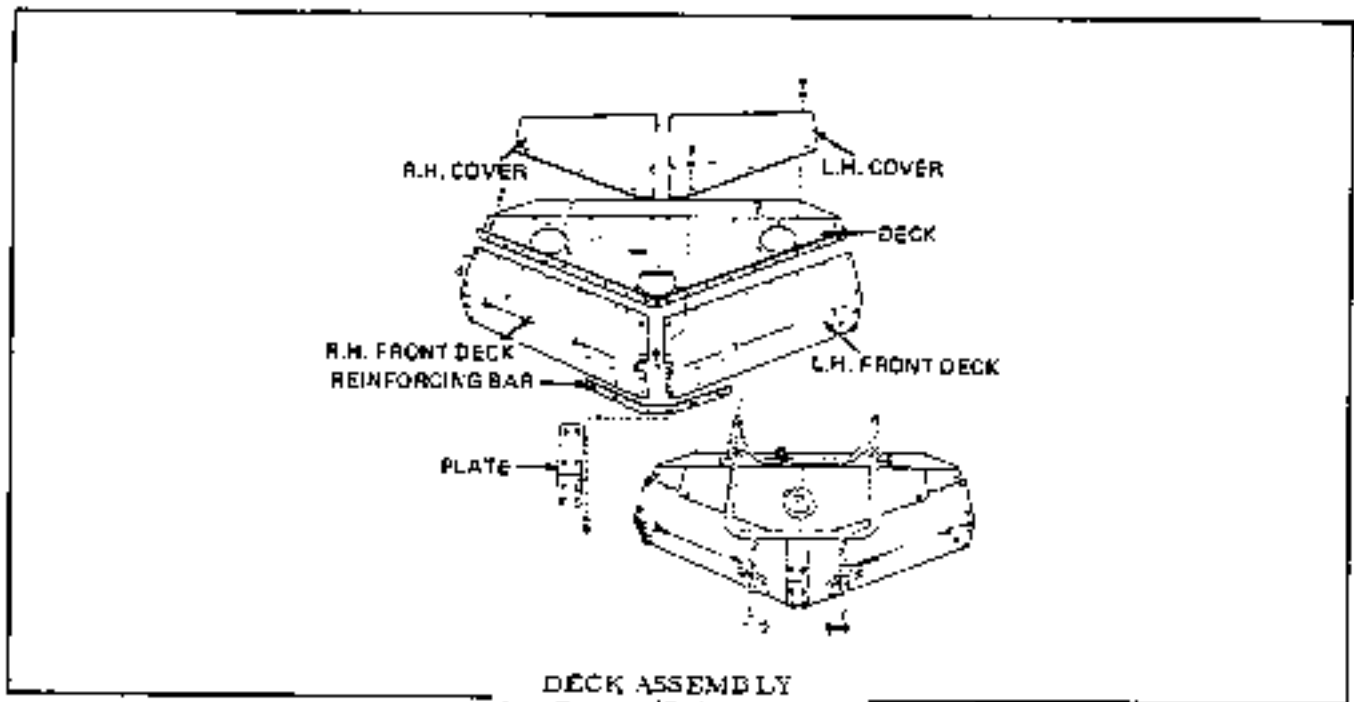

DECK ASSEMBLY
1st Type w/Bolted Frame

DECK ASSEMBLY (1st Type)

The deck assembly is serviced in components.

When replacing a part, remove the bolts attaching that part.

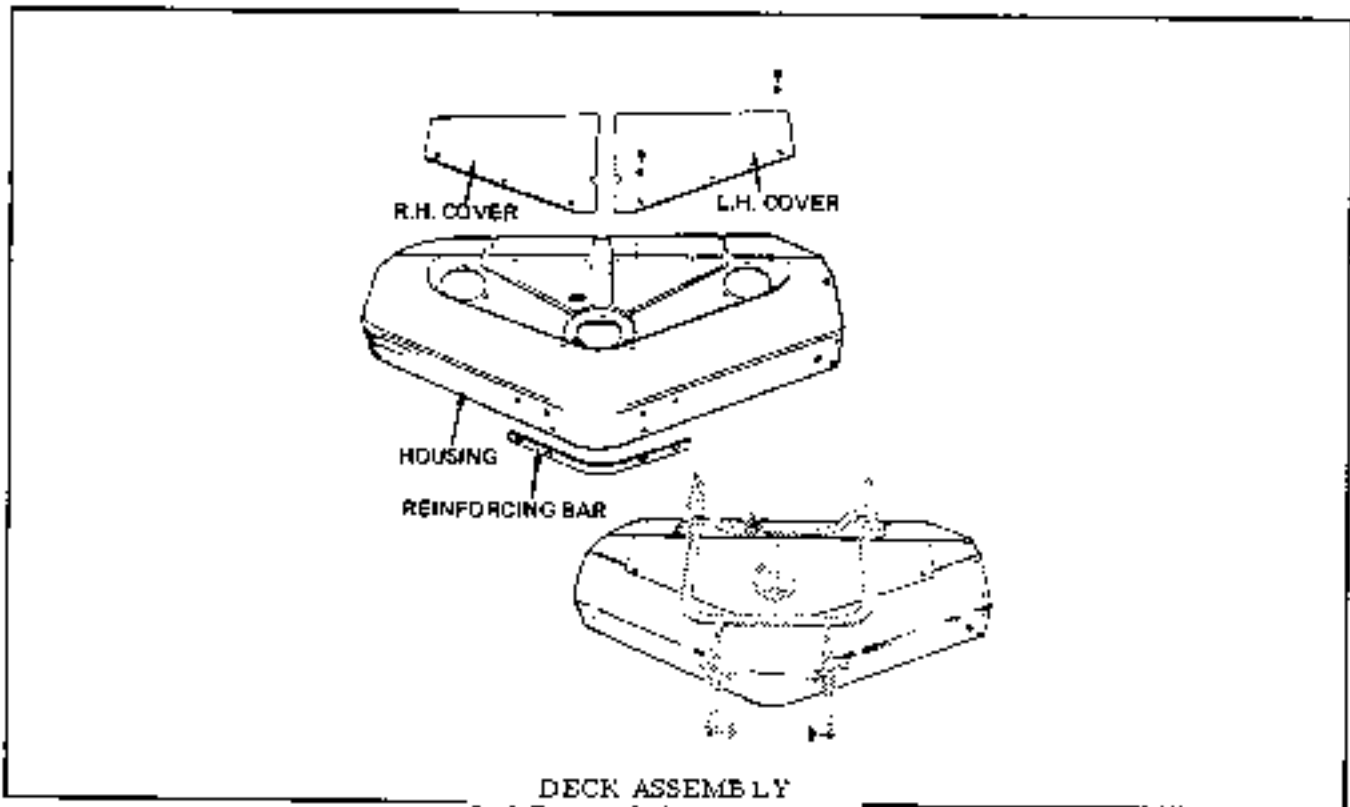

DECK ASSEMBLY
2nd Type - 1 Piece Housing

DECK ASSEMBLY (2nd Type)

The housing is available through service parts.

When replacing the housing remove all components from the old and install in the new.

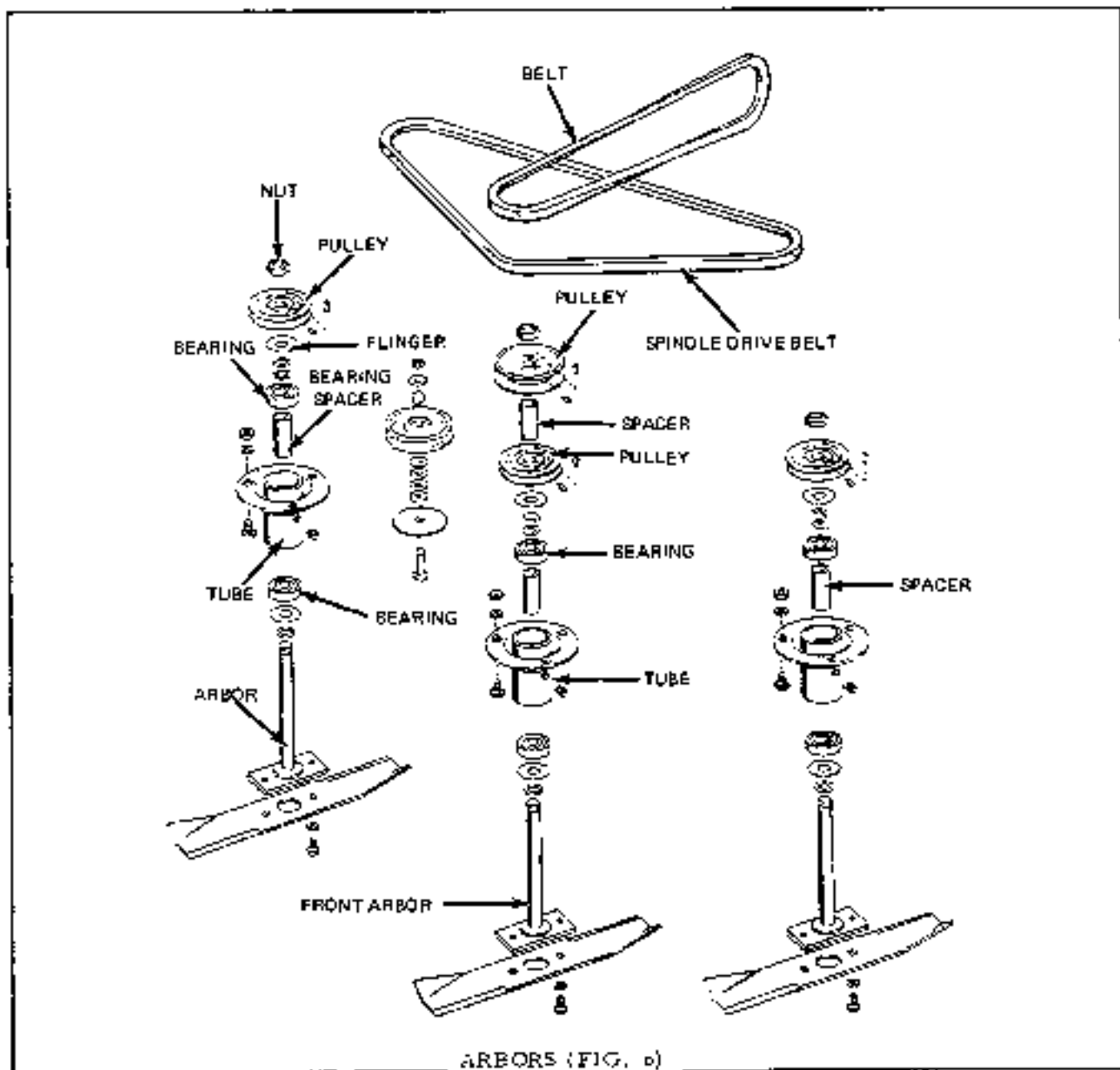

ARBORS (FIG. 6)
42" Rotary Mower

ARBOR SERVICE (Fig. 6)

1. Remove R.H. and L.H. deck covers.
2. Loosen idler pulley. Remove spindle drive belt.
3. Remove 3 bolts holding arbor assembly.
4. Remove entire arbor assembly.
5. Remove lock nut.
6. On the front arbor assembly, remove cross drive pulley and cross drive pulley spacer.
7. Remove arbor pulley.
8. Remove arbor assembly from arbor tube assembly.
9. Remove spacers and bearings from arbor tube assembly.
10. Wash bearings, spacers and tube assembly to remove grit and old grease.
11. Replace bearings if necessary.
12. Pack bearings with grease before installing in arbor tube assembly.

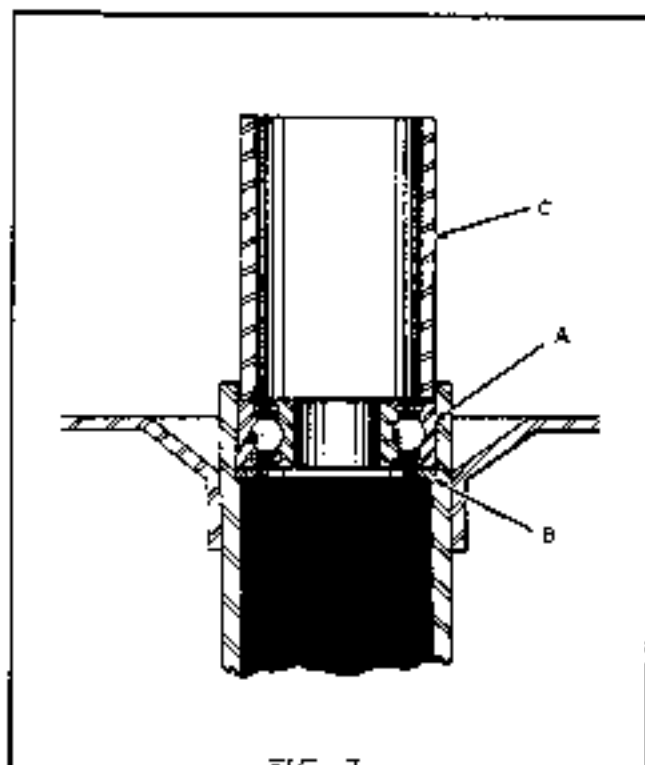

FIG. 7

1. Install the upper bearing 'A' so that the green face of the bearing is toward the backing ring 'B' in the tube assembly. Use a tube 'C' or sleeve to press against the outer race of bearing and press the bearing firmly against the backing ring. (Refer to Fig. 7).

2. Insert a 'dummy shaft' 'D' through the bore of the upper bearing and invert the tube assembly. Rest the upper bearing 'A' on a surface 'E' that will give equal support to both the inner race and outer race of the bearing. Refer to Fig. 8.

3. Install the sleeve 'F' over the 'dummy shaft' and place the lower bearing 'G' in position over the 'dummy shaft' in the tube assembly. Press the lower bearing into the tube, with the green face of the bearing facing the upper bearing, until the inner race is in firm contact with the end of the sleeve.

NOTE: Use a pressing tool with a .005" counter bore or relief slightly larger than the diameter of inner race, or a cylinder with a .005" shim

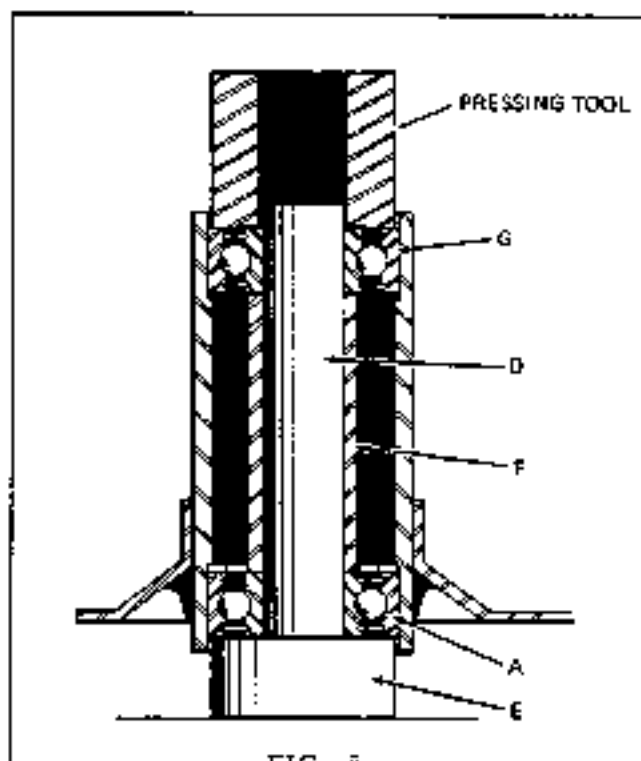

FIG. 8

washer to press on outer race only. Press the inner race and outer race at the same time. Refer to Fig. 8. In effect, the pressing tool should push the outer race of the bearing .005" deeper into the tube than the inner race.

4. Remove the 'dummy shaft' and install the lower washers on arbor shaft and insert arbor shaft through both bearings. Install the upper washers, key, pulley and hex lock nut.

NOTE: When using a 'New' lock nut, tighten to 70 ft. lbs. torque. Use a torque wrench. When using a 'Used' locknut, tighten to 45 ft. lbs. torque. If the lock nut has been tightened once and then loosened, it is a used lock nut and will require the 45 ft. lbs. torque.

5. When correctly assembled, the arbor shaft can be rotated by a twisting force of approximately 1 inch lb.

NOTE: 1 inch lb. is equal to the force applied by a 1 lb. weight 1 inch from the center line of the arbor shaft.

CROSS DRIVE BELT
42" Rotary Mower

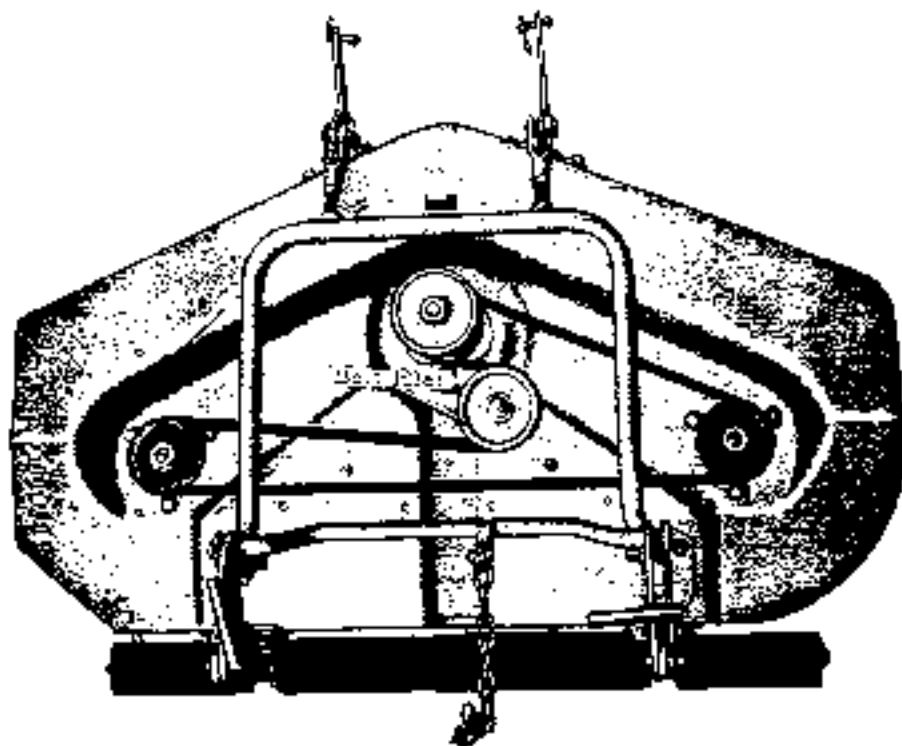

BELT IDLER

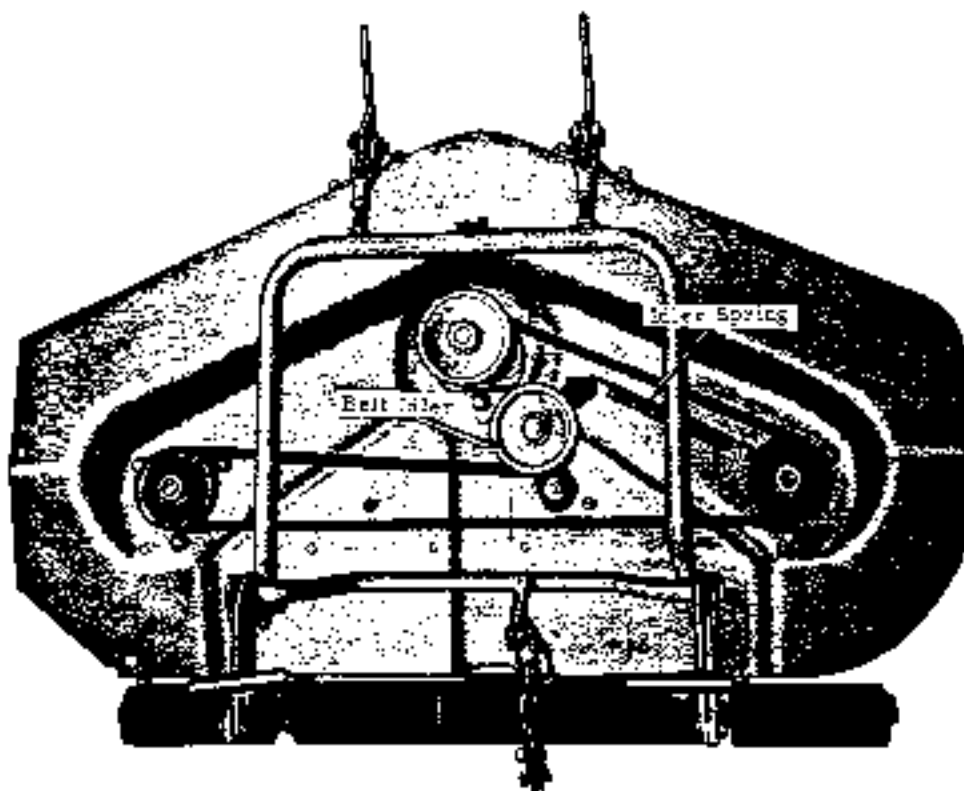

SPRING LOADER IDLER

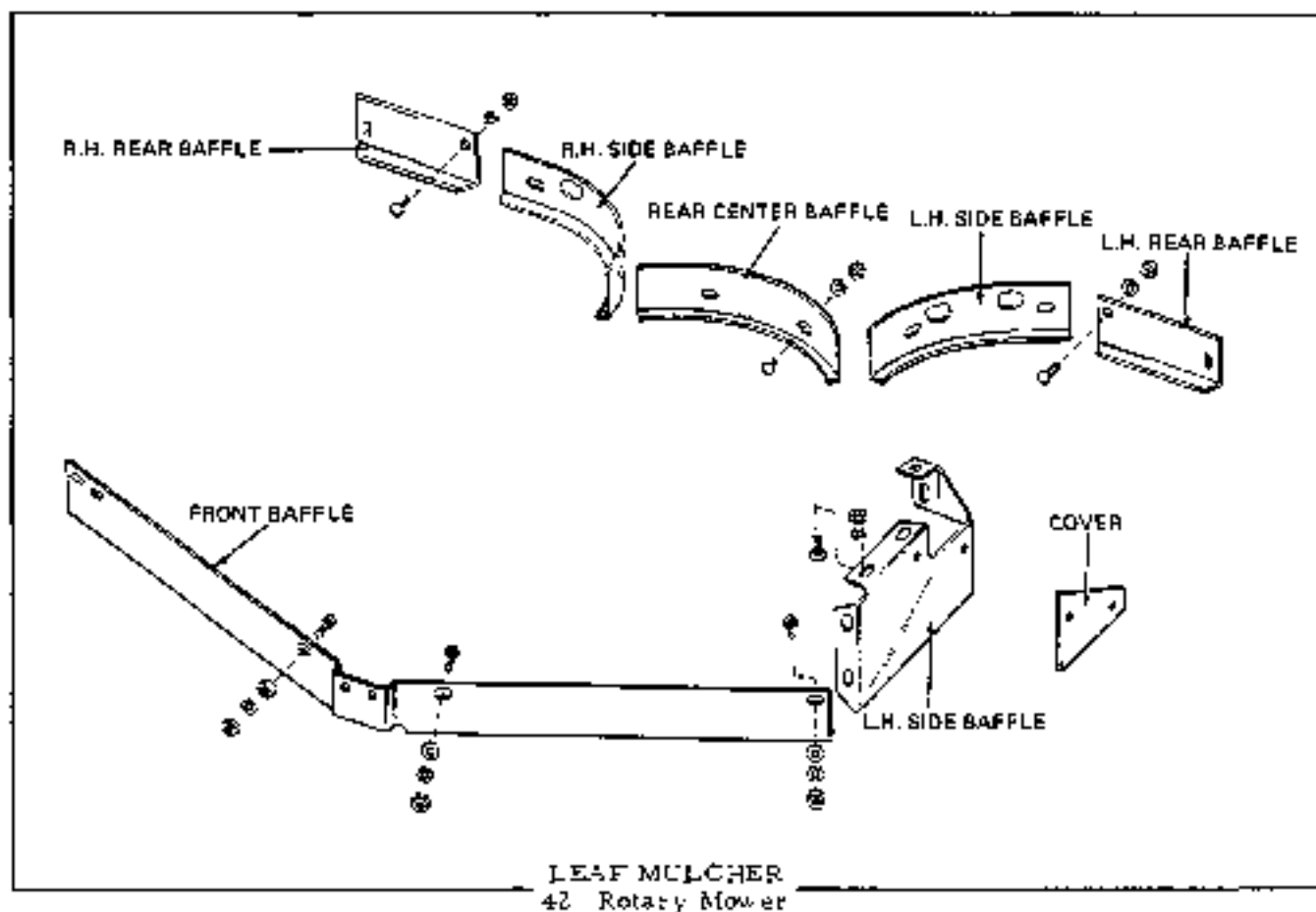

The leaf mulcher attachment is available as a machinery item and its components are available through service parts.

TROUBLE SHOOTING 42" ROTARY MOWER

1. Be sure unit is properly adjusted and attached to tractor.
2. Remove mower from tractor and clear all grass clippings and material from mower housing.
3. Rotate blade and see that all blade ends are level with each other and will cut even and on a horizontal plane.
4. Check blade conditions - may need to be sharpened.
5. Check curved baffle plate to see it is not bent or damaged.
6. Check mower and P.T.O. drive belt for proper adjustments and tension.
7. For some mowing conditions, it may be advisable to use a ground speed reduction group. The 2025005 is a 10" transmission, drive pulley and belt available for field installation. The 8" pulley 2025271 with belt 2025492 normally used for the tiller can be obtained from parts.
8. Due to the fact the 42" rotary mower is a heavy unit it will tend to ride down the grass stubble and a 2" cut will be very short. The mower is designed to cut from 2" to 5" for lawn work. A better looking lawn and best care for grass is maintained by cutting often and not too short.
9. With the 42" rotary mower working behind the travel of the tractor front wheels, it may be necessary to over-cut the width of the wheel mark in the mowed grass. This would leave no uncut grass for best appearance on estate lawns, etc.
10. If mower is properly adjusted and in apparent good condition, but seems to require excess engine power - Check all blade drive assemblies. The rotor spindles should turn with 1" to 2" lbs. pull. This can be checked by removing mower drive belt shield and drive belt. If this pull is up to 5' lb. or more the unit will rob power from the tractor. Repair or replace necessary parts of the rotor spindle. Tight bearings, bent rotor shaft or spindle housings may be caused by hitting obstructions.

REEL MOWERS

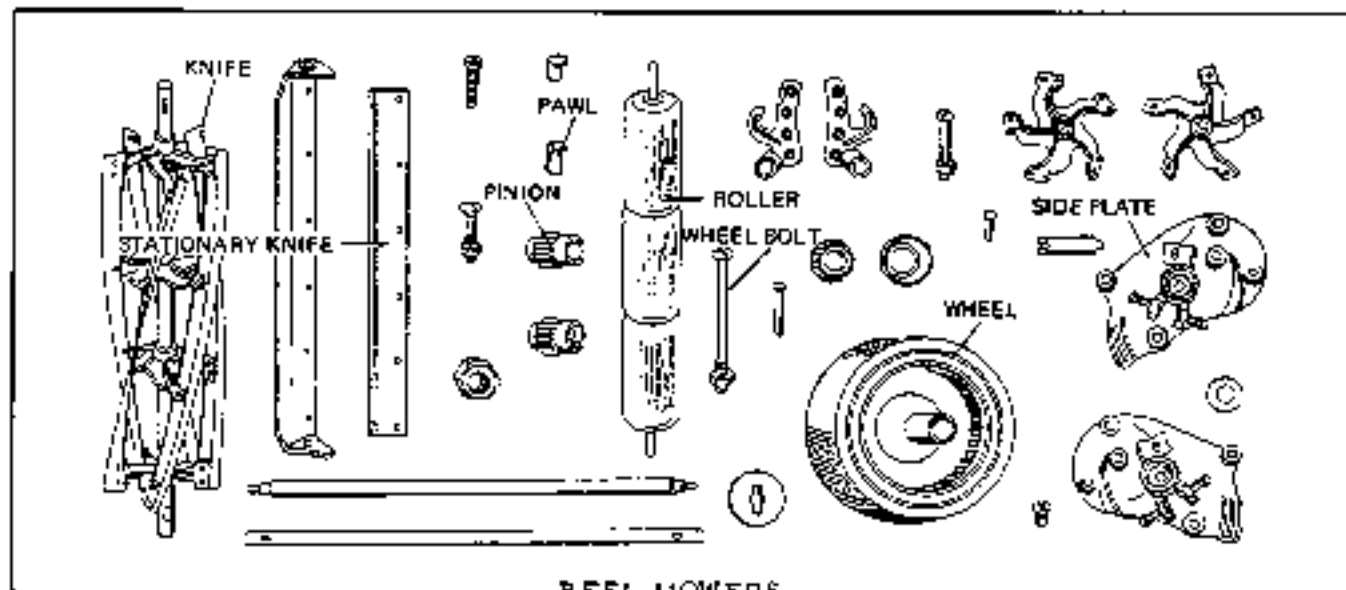

REEL MOWERS
1st Type

PERIODIC SERVICE (1st Type)

- | | |
|--|---|
| <ol style="list-style-type: none"> 1. Remove wheel bolt and washer. 2. Remove wheel assembly. 3. Remove pinion and pawl. 4. Clean pinion, pawl and inside of wheel assembly to remove debris and old grease. | <ol style="list-style-type: none"> 5. Inspect for wear, replace if necessary. 6. Grease well and reassemble. <p>Clearance between cylinder knives and the stationary knife is adjusted by loosening and tightening the castback regulating setscrew.</p> <p>Height of cut is regulated by moving the roller and roller brackets up or down.</p> |
|--|---|

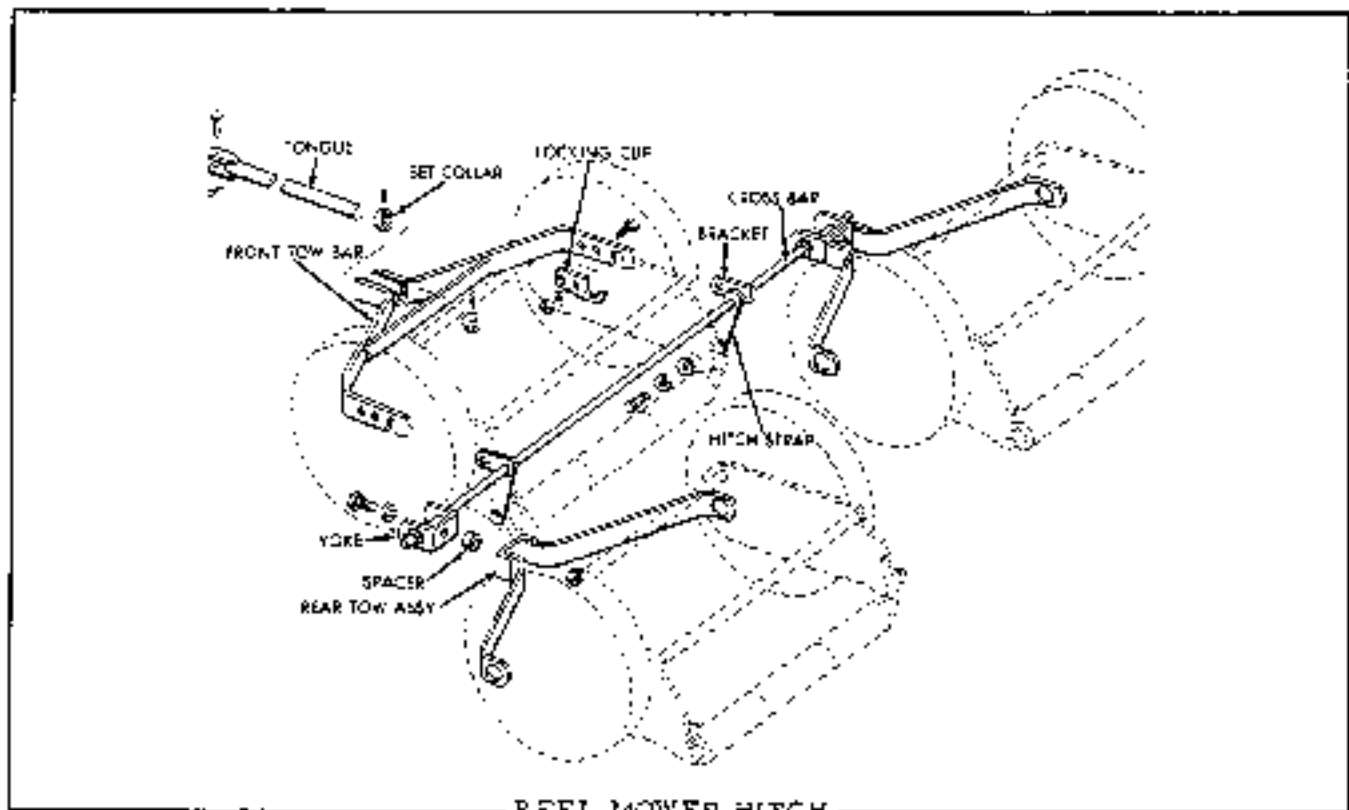

REEL MOWER HITCH
1st Type

The hitch assembly is serviced by components available through service parts stock.

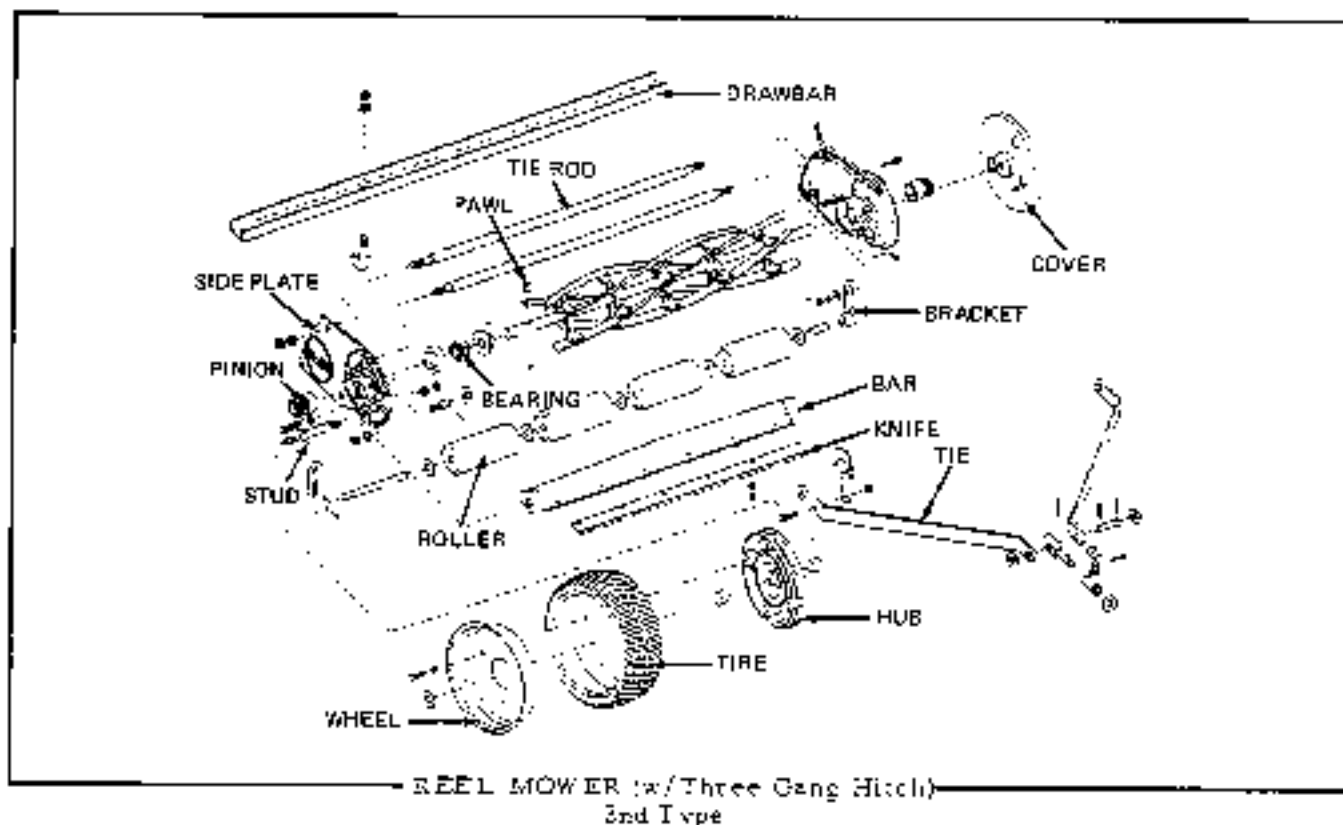

PERIODIC SERVICE (2nd Type)

1. Remove wheel stud.
2. Remove drive wheel assembly.
3. Remove pinions, pawl and bearing.
4. Clean pinions, pawl and bearing and drive wheel.

5. Inspect, replace if necessary.
6. Grease well and reassemble.

Clearance between lower knife and cutter assembly regulated by adjusting screws in side plates.

Height of cut regulated by roller height.

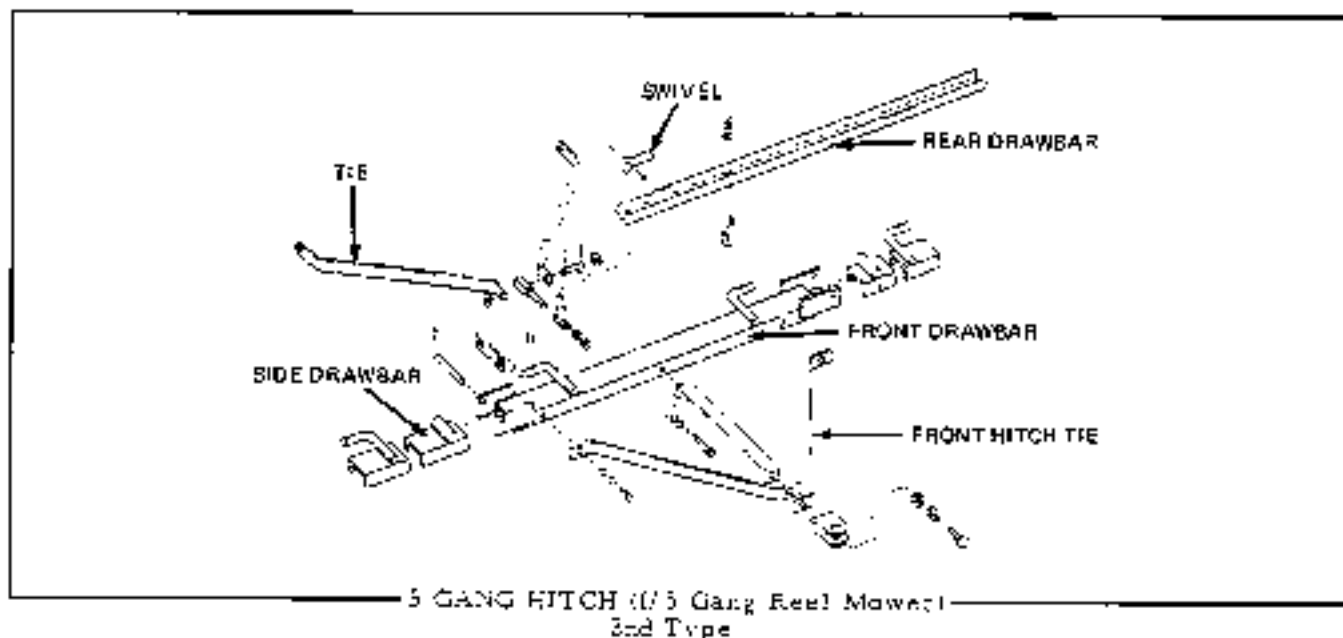

The hitch assembly is serviced through service parts store.

E

SICKLE BAR MOWER

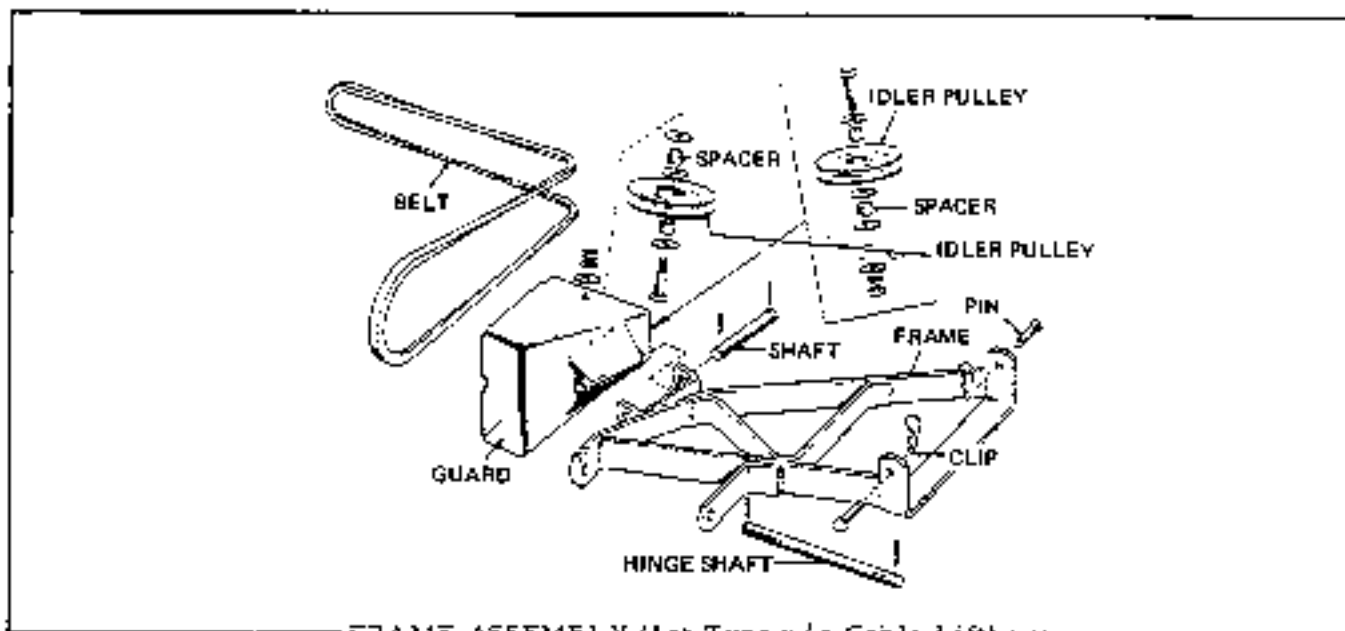

FRAME ASSEMBLY (1st Type w/o Cable Lift)
46' Sickle Bar Mower

The idler pulleys contain bearings. During sickle bar service inspect these bearings.

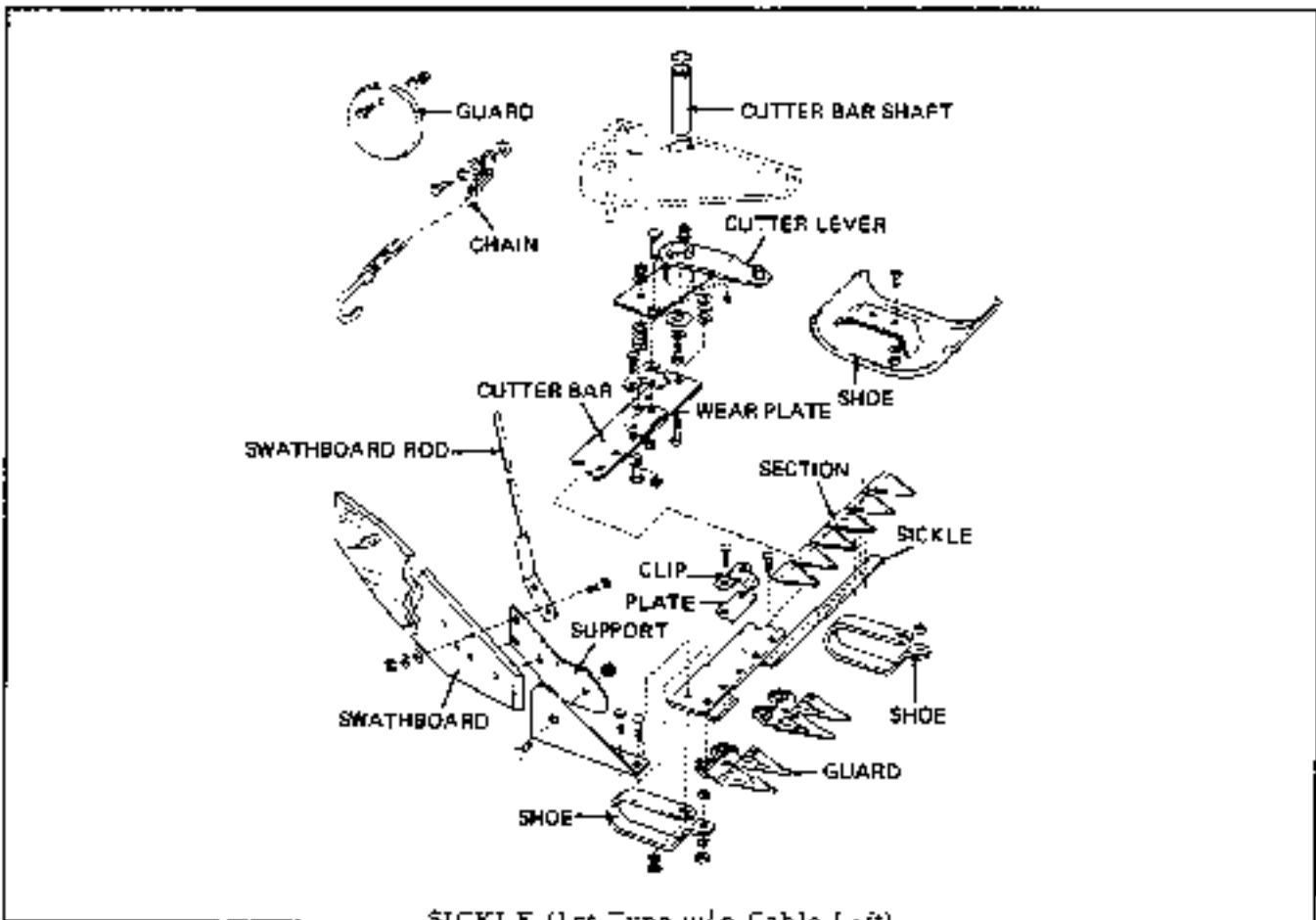

SICKLE (1st Type w/o Cable Lift)
46' Sickle Bar Mower

SICKLE BAR REMOVAL

1. Remove sickle head from the section bar.
2. Slide section bar out through under tractor.

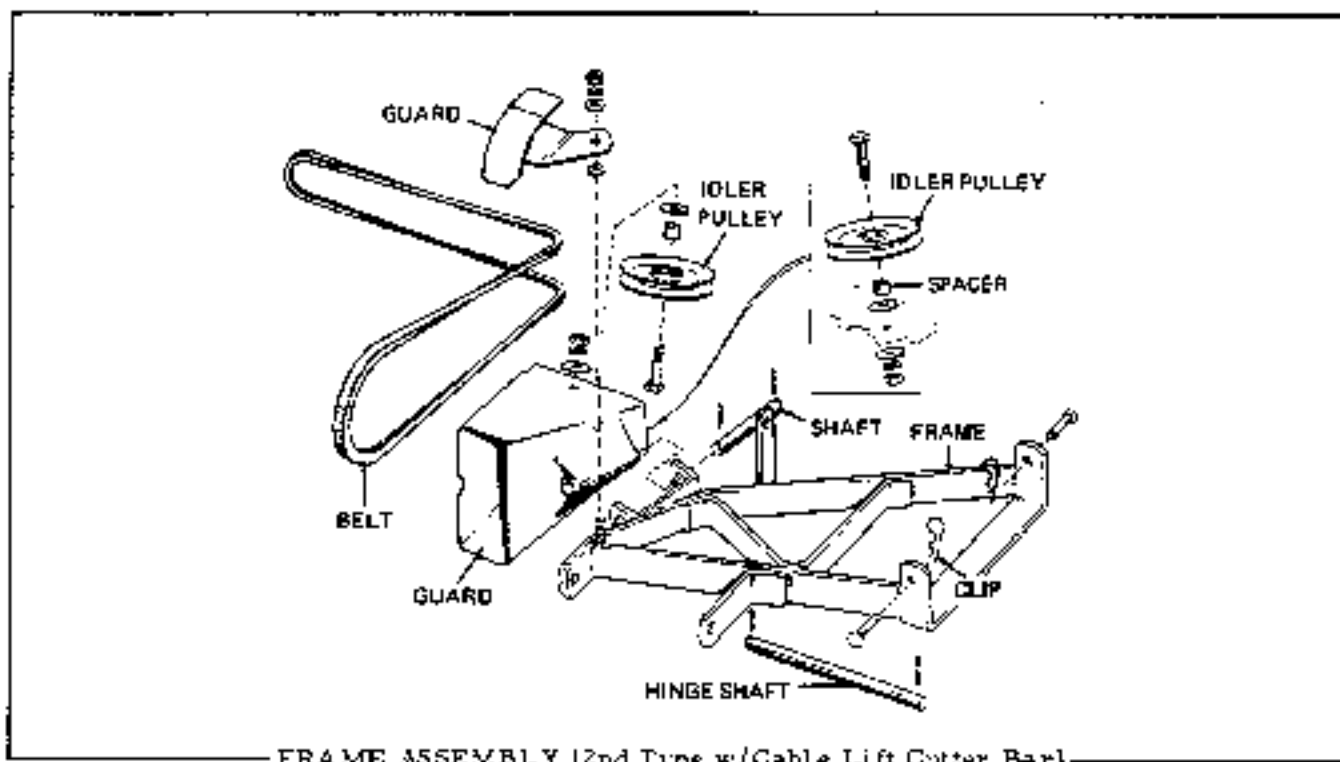

FRAME ASSEMBLY (2nd Type w/Cable Lift Cutter Bar)
46" Sickle Bar Mower

The idler pulleys contain bearings. During sickle bar service, inspect these bearings.

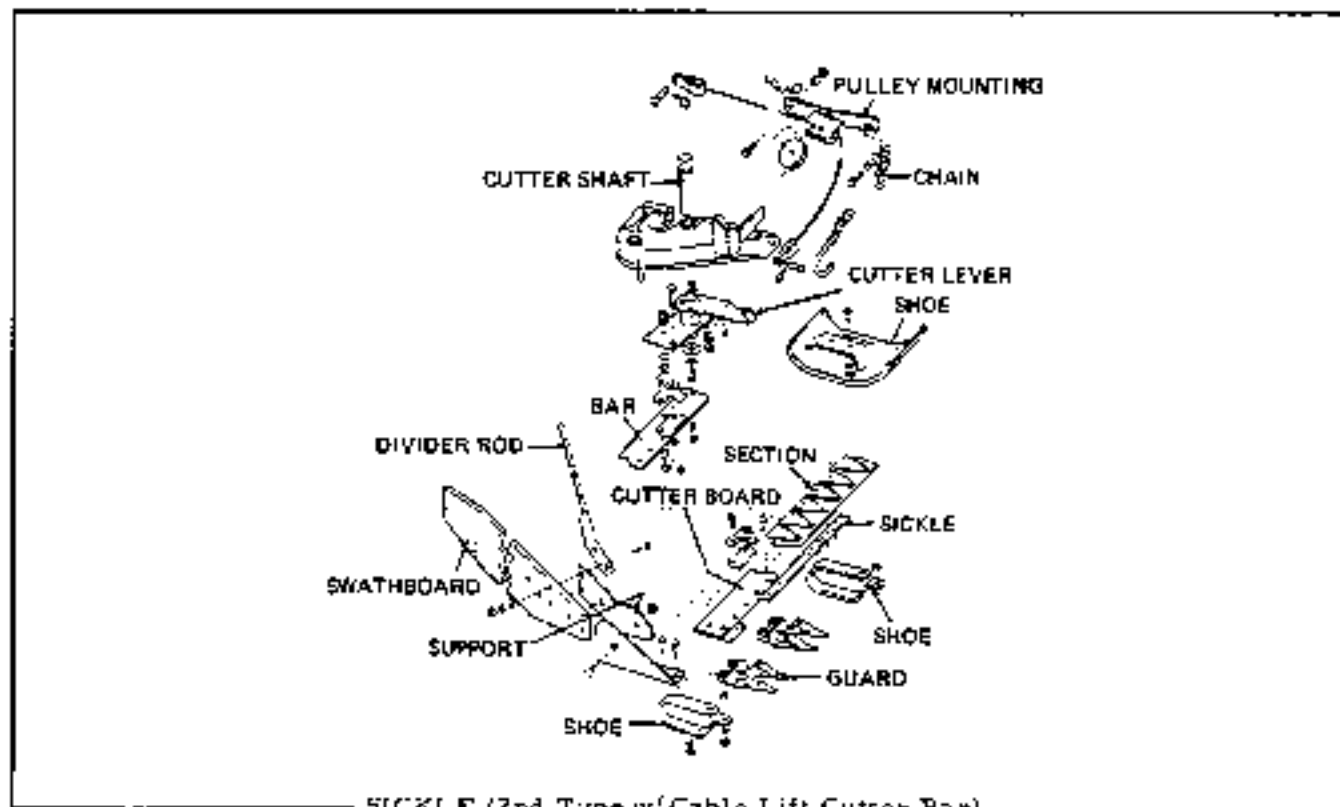

SICKLE (2nd Type w/Cable Lift Cutter Bar)
46" Sickle Bar Mower

SICKLE BAR REMOVAL

1. Remove sickle head from the section bar.
2. Slide section bar out through under tractor.

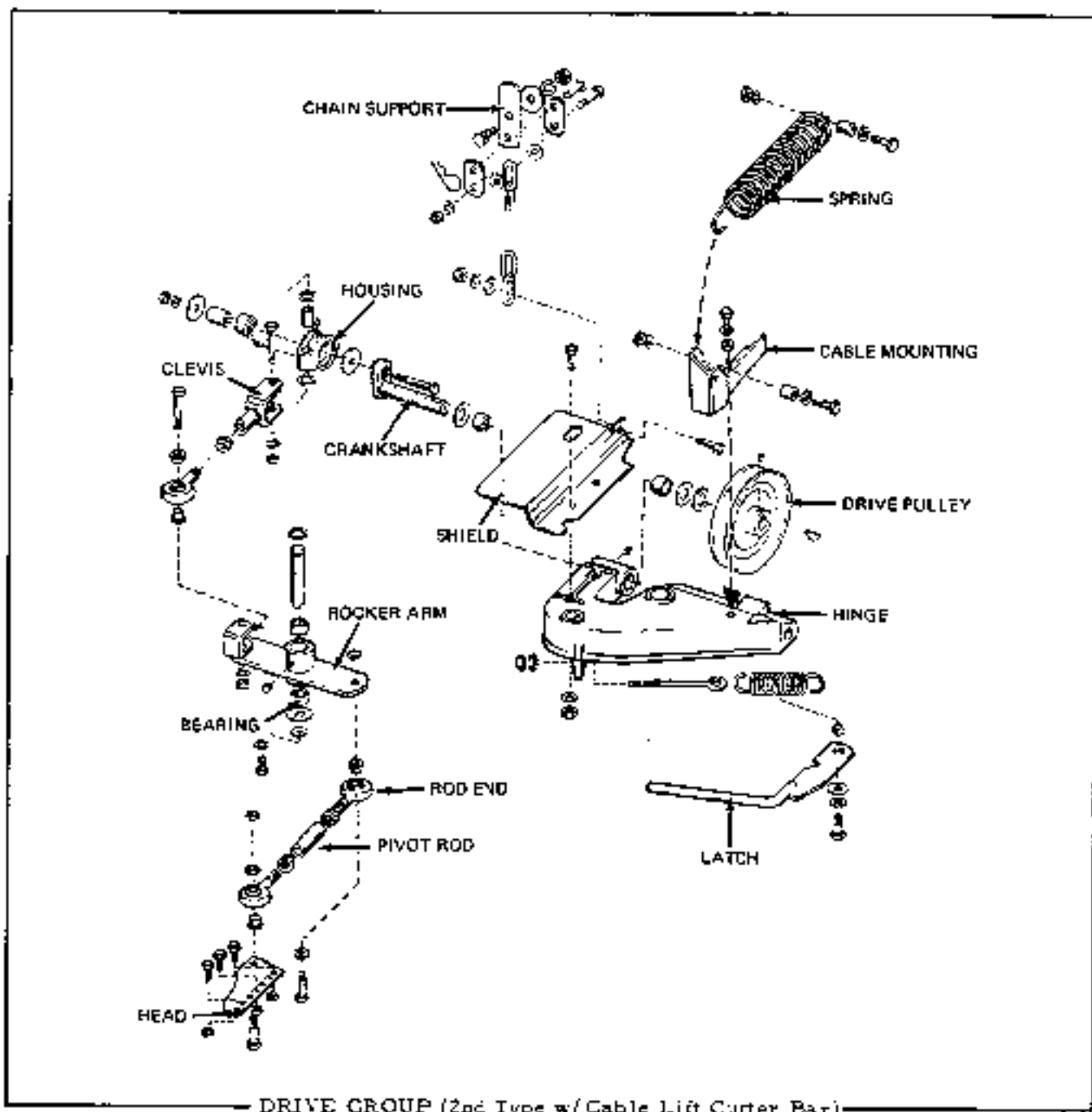

DRIVE GROUP (2nd Type w/ Cable Lift Cutter Bar)
46" Sickle Mower

46" SICKLE BAR DRIVE (2nd Type)

- | | |
|--|---|
| <ol style="list-style-type: none"> 1. Remove sickle head from sickle bar. 2. Remove rod ends from sickle head and from rocker arm assembly. 3. Remove rocker arm assembly. 4. Remove pitman clevis assembly. | <ol style="list-style-type: none"> 5. Remove drive pulley. 6. Remove crankshaft. 7. Disassemble pitman bearing and housing. 8. Clean and inspect parts. 9. Replace necessary parts. 10. Oil bearing surfaces before reassembly. |
|--|---|

KNIFE CARE

1. Keep knife straight and sections sharp.
2. Sections should be replaced when they are worn or ground down shorter than their original length.
3. Remove knife section by shearing the rivets. Let knife back rest on vise jaw with point of section down. Strike the section a sharp blow with a hammer.
4. Always shear rivets instead of punching them out. Be careful not to enlarge holes in knife back or new rivets will be loose.
5. After shearing, drive the rivets out of knife back (from the sheared end) with a drift punch.
6. Place section on knife back with bevel side up. Insert rivet through knife back and section. Place knife on repair block or anvil with rivet heads down to hold them in place.
7. Expand the rivet with hammer to make it tight, then set the rivet with a rivet set. Check to be sure that the section is tight and rivet heads well formed.
8. After sections have been replaced, check knife for straightness.
9. The value of a sharp knife cannot be over-emphasized. Dull knives cause uneven cutting, clogging, increased draft and excessive mower wear. Remember a tractor doesn't know when a knife is dull, but a team of horses pulling a mower will pretty soon let a farmer know the knife needs sharpening.
10. When sharpening a section, maintain the original width of bevel and angle of shear. A narrow blunt bevel will not shear the stems easily. A wide keen edge nicks too easily.
11. Knife sections should be replaced when they are bent, nicked, worn or ground to a point. Any sharpening after the section is worn to a point reduces its length and its effective cutting surface.

ROTARY TILLER

F

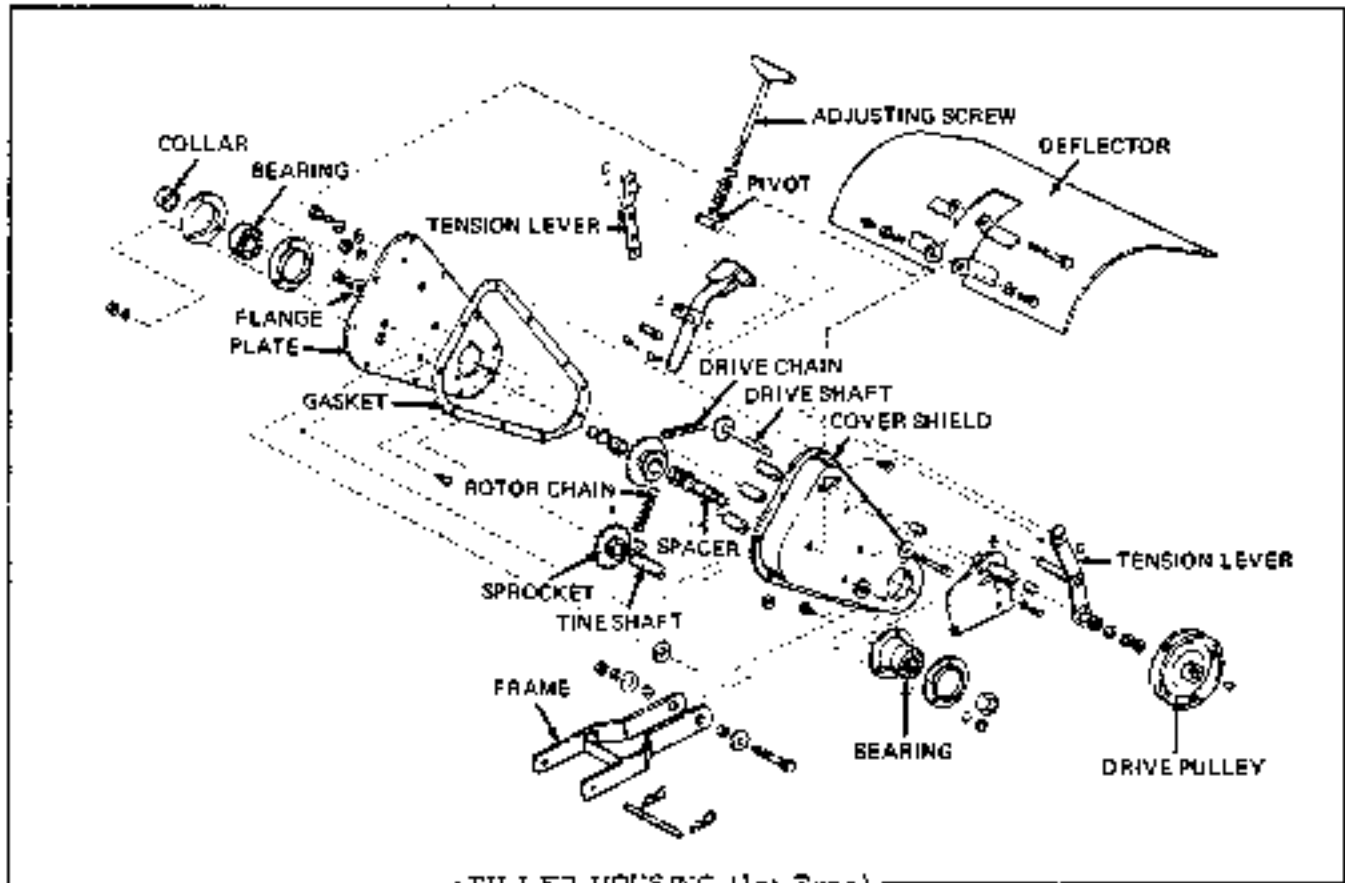

TILLER HOUSING (1st Type)
32" Rotary Tiller

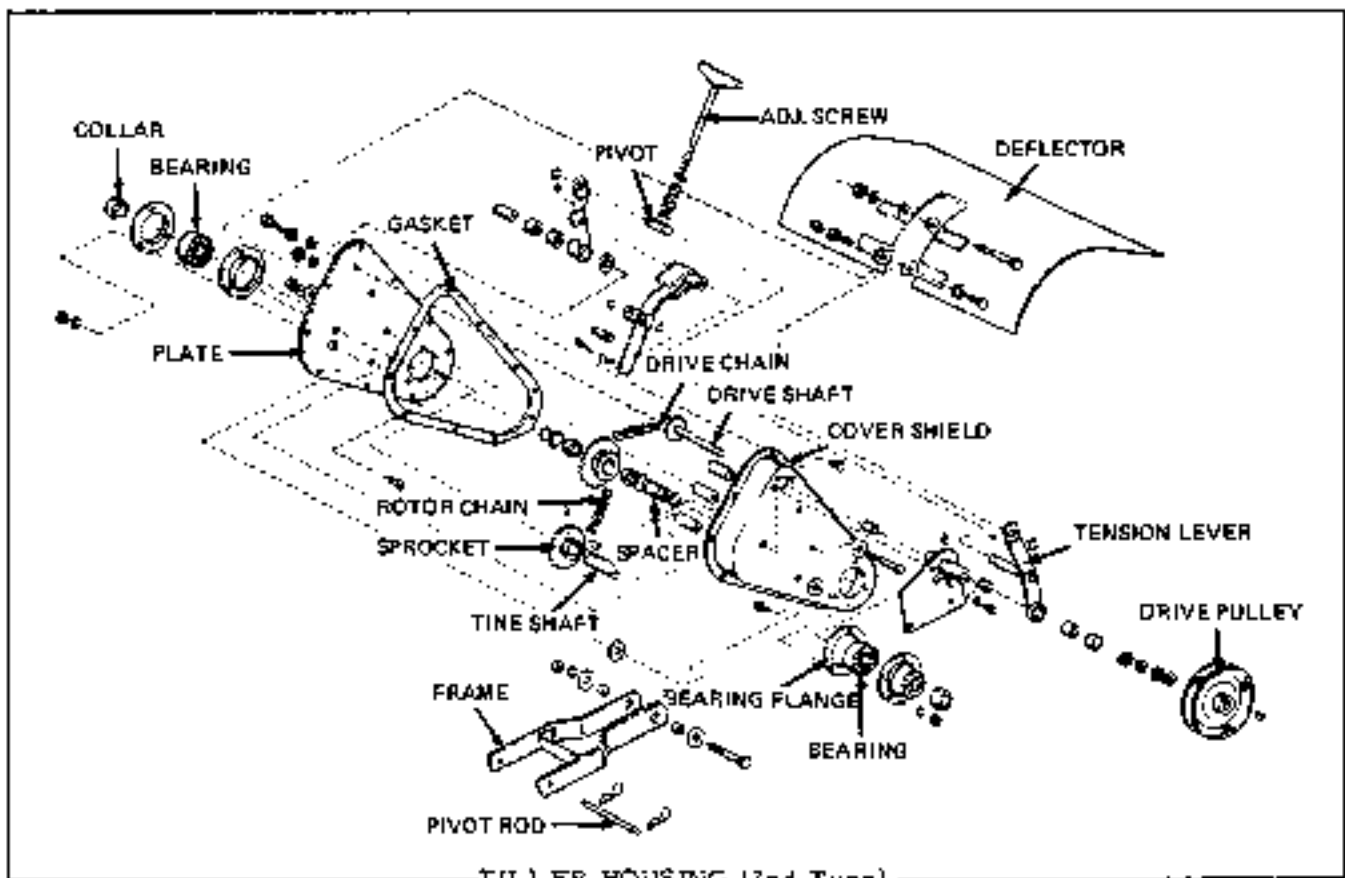

TILLER HOUSING (2nd Type)
32" Rotary Tiller

32. TILLER HOUSING DISASSEMBLY (1st & 2nd Type)

1. Remove drive pulley.
2. Remove cover shield by removing capscrews.
3. Remove tire assemblies by removing pin and cotter key next to housing.
4. Remove hitch assemblies. Remove lower hitch by taking out the long capscrew, slide the frame assembly forward to clear housing. Remove capscrew from belt tension arm (R.H.) remove lock ring from pivot pin and setscrew. Separate belt tension arm and remove from the housing.
5. Remove bearing collar on chain guard plate assembly side.
6. Remove capscrews and carriage bolt holding plate to chain guard assembly.
7. Remove plate, bearing and gasket. Remove bearing and bearing flanges from plate.
8. Wash entire assembly to remove grease.
9. Remove drive chain by removing it from drive shaft sprocket and then from the sprocket assembly.
10. Remove sprocket assembly from rotor chain. Remove sprocket assembly from housing. Shaft can be pressed out at sprocket.
11. Remove R.H. bearing collar and remove bearing flange.
12. Remove bearing, tire shaft, and rotor chain and sprocket.
13. Inspect chains, sprockets, bearings and bushings for wear. Replace if necessary.

32" TILLER HOUSING ASSEMBLY (1st & 2nd Type)

1. Install guard assembly bearing.
2. Install tire shaft and drive shaft.
3. Install chains.
4. Install sprocket assembly holding it in place with one capscrew.
5. Install guard spacers using the long capscrews to hold them in place.
6. Grease chain assemblies liberally (use approximately 1 lb of general purpose grease).
7. Reinstall cover plate, being sure the spacers and the sprocket assembly line up correctly.
8. Remove long capscrews.
9. Reinstall belt tension lever assembly, secure pivot pin with lock ring and shaft with setscrew.
10. Reinstall frame assembly with long capscrew. Reinstall long capscrew through housing.
11. Reinstall tire assemblies.
12. Reinstall cover assembly.
13. Reinstall drive pulley.

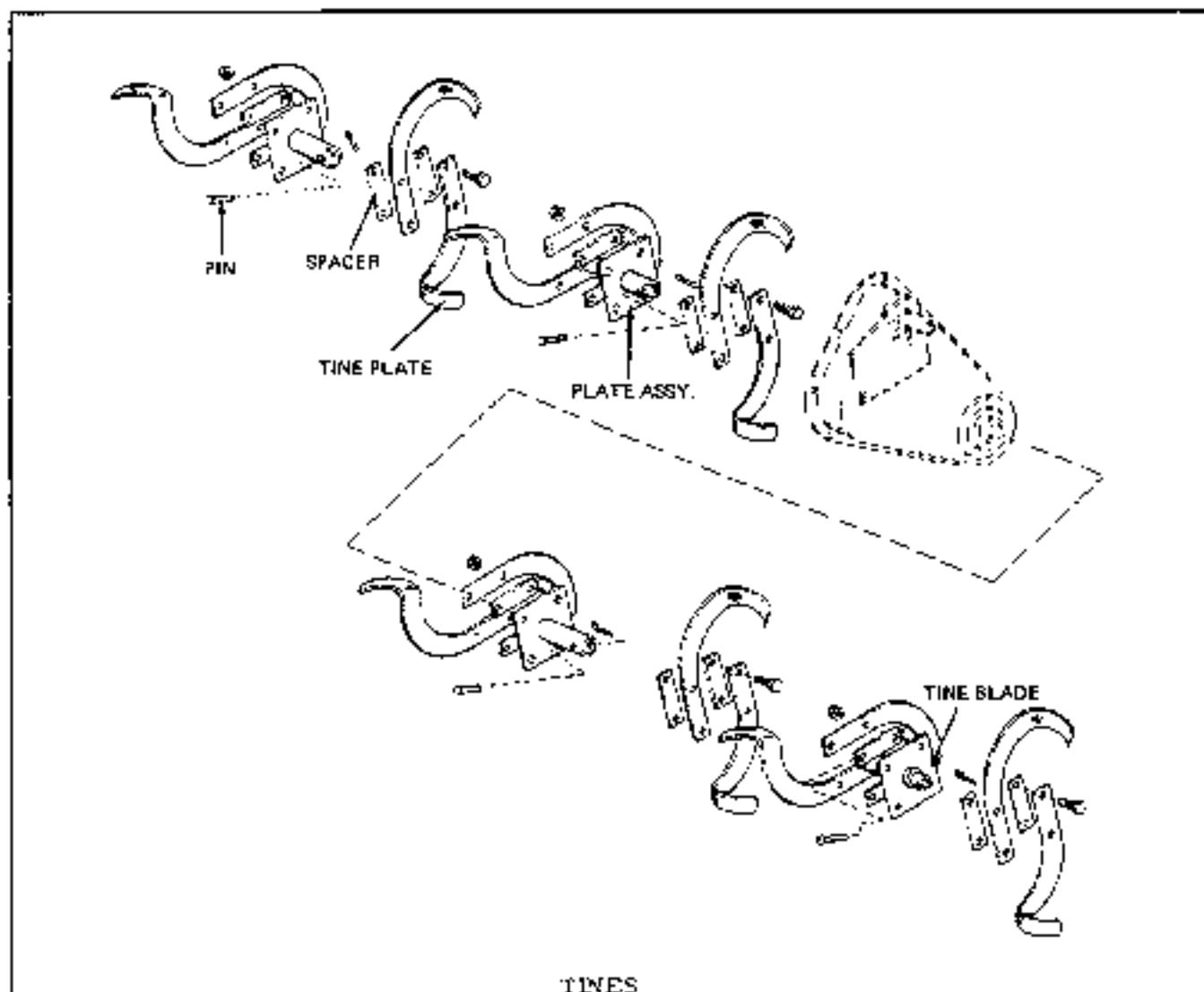

TINES
32" Rotary Tiller

32" ROTARY TILLER

Disassembly tine sections by removing the four capscrows holding the tines to the plate assembly.

REASSEMBLY

1. Place plate assembly on table with long tube up.
2. Place one tine below the plate on the side nearest you. Point down, pointing to the left. On the side farthest from you, place a tine, point

down, pointing to the right. Hold in place with capscrows.

3. On the left side of the plate assembly, place a tine on the top with the point up pointing away from you. On the right side, place a tine on the top with the point up pointing toward you.
4. Fasten all tines in place securely with the lockwashers and nuts provided.

NOTE: Some assemblies have a spacer between the tine and plate assembly.

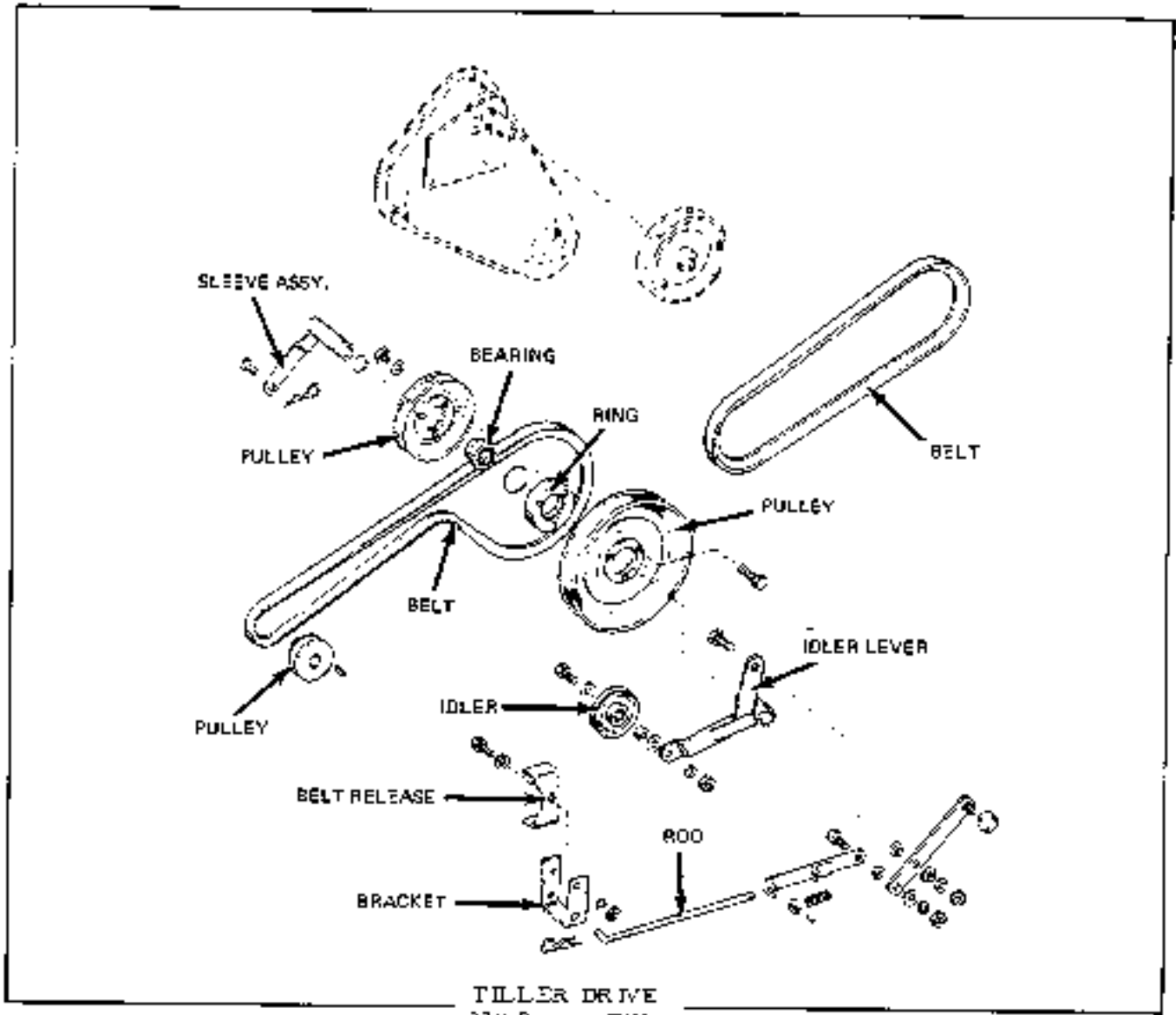

TILLER DRIVE
32" Rotary Tiller

Between the double pulleys there is a bearing.
During service this should be checked.

SNOW THROWER
Tractor Mounted



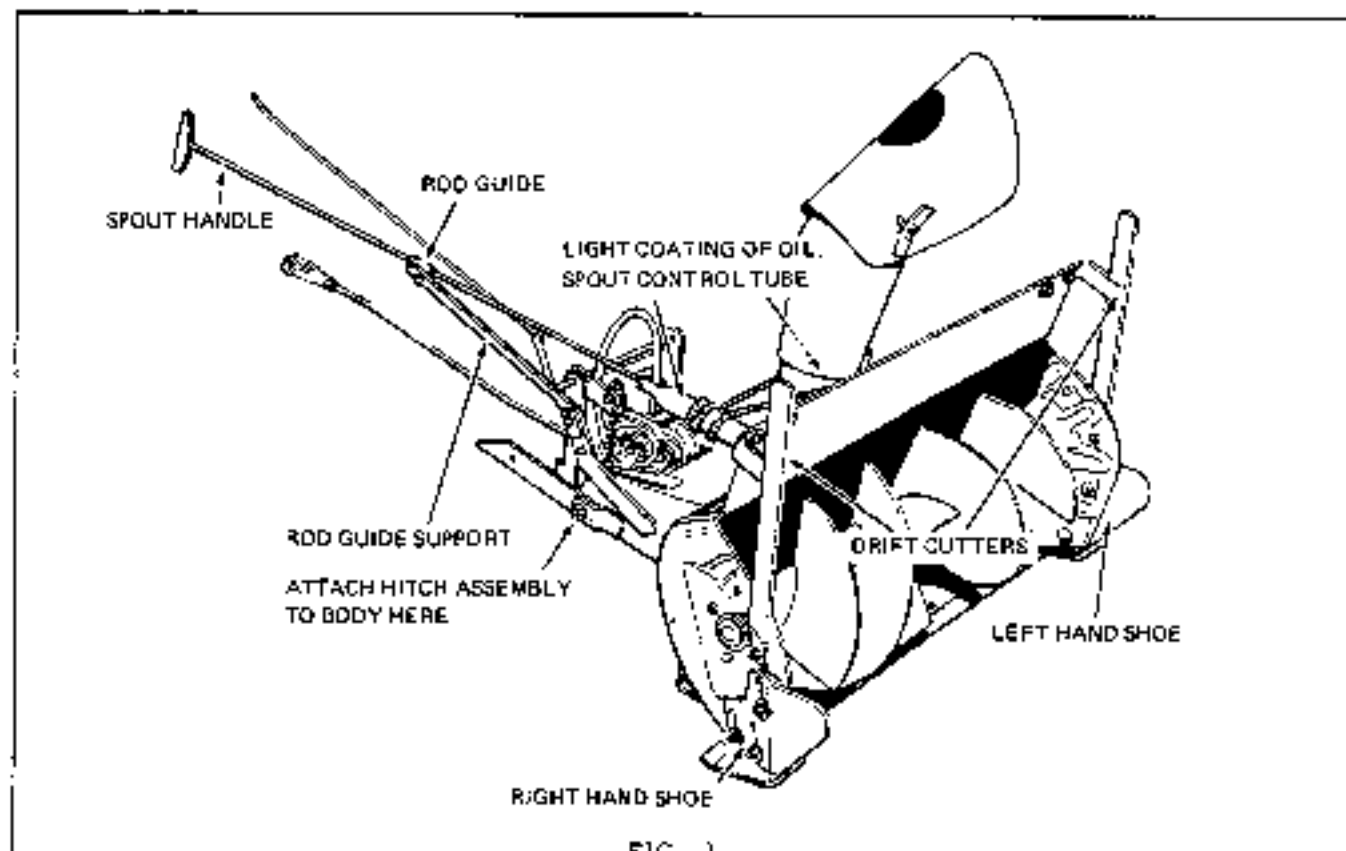

FIG. 1

ASSEMBLY

1. Attach left and right hand shoe to body assembly with 3/8-16NC-3/4 long carriage bolt, 3/8 plain and 3/8 lockwasher. Secure with 3/8-16NC hex full nut, which is on outside of shoe at desired elevation for your specific needs. (See Fig. 1).
2. Attach left and right hand drift cutters to outside of body assembly with 5/16-18NC-3/4 long hex capscrews, 5/16 plain and 5/16 lockwashers. Secure with 5/16-18NC hex full nut. (See Fig. 1).
3. Attach hitch assembly to rotor body assembly with 3/8-24NF-2-1/2 long hex head bolt, 3/8 plain and 3/8 spring washer. Secure in place with 3/8-24NF hex full locknut. (See Fig. 1).
4. Place V-belt around pulley in rotor body housing.
5. Remove 5/16-18-1/4 long hex capscrew, lock and plain washer from tractor directly below front mounted P. T. O. shaft. Insert through two belt fingers and reassemble. **DO NOT TIGHTEN.** (See Fig. 2).
6. Attach front mounted P. T. O. pulley to shaft. Secure 3/8-24NF setscrew down on key. (See Fig. 2).
7. Attach hitch assembly to tractor with two pins and two spring clips. (See Fig. 2).
8. Place belt around front mounted P. T. O. pulley. (See Fig. 2). The belt should be a minimum of 54-1/4" in length.
9. Install belt stops so the left belt stop is nearest the tractor frame and the right belt stop nearest the bolt head. They should be adjusted to approximately 1/32" from the belt and pulley when the thrower is in the engaged position.
10. Apply a light coating of oil to neck of discharge spout. Install spout and extension as shown. (See Fig. 1).
11. Attach rod guide support to top hole of lift rod bracket with 3/8-16NC-1/4 long capscrew, 3/8 lockwasher and 3/8-16NC hex full nut. **DO NOT TIGHTEN.** (See Fig. 1).
12. Insert handle assembly into spout control tube assembly and secure with 5/32" x 1" long cotter pin. Insert spout control tube assembly into bearing and secure in place with 2-1/8" x 3/4" long cotter pins. Insert handle assembly through rod guide. Tighten 3/8-16NC hex full nut on rod guide support which is in top hole of lift for bracket, at desired angle of operator while on seat. (Fig. 1)

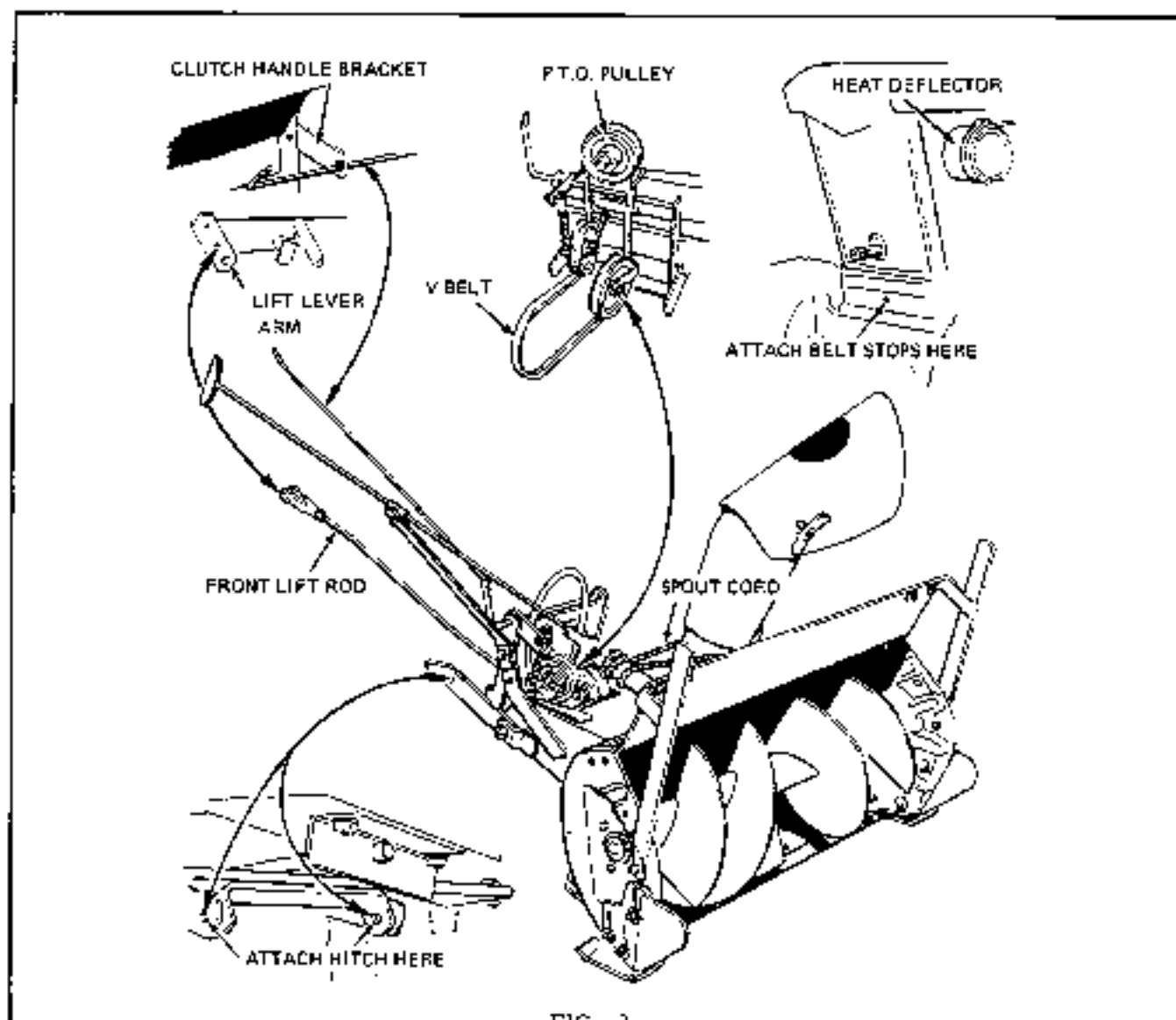

FIG. 2

13. Position discharge spout directly forward. Position control tube so that cord clamp faces side of spout. Provide two (2) coils of cord on both sides of clamp. Position free ends of cord around spout and clamp securely into position after removing all slack from cord. (See Fig. 2).

14. Remove forward, top capscrew from R. H. side panel. Insert clutch handle bracket between side panel and side member of fuel tank and steering post support assembly. Secure with same capscrew and lockwasher. (Fig. 2)

15. Insert clutch control rod through bracket and attach to clutch pivot and secure in place with spring clip. (See Fig. 2). The addition of plain washers, nylon washers and locknut to the clutch linkage assembly will assure a positive disengagement when the clutch handle is pulled in the disengaged position. The locknut should be set to a torque setting of 4 ft. lbs. It should require

movement of the lever to engage or disengage the thrower.

16. The set collar should be adjusted up or down to assure the backside of the belt rides properly in the idler pulley. A good starting adjustment is approximately 3" overall spring length, engaged. Be sure spring is not fully collapsed. Be sure setscrew is properly indexed not to strike housing.

17. The lift lever quadrant on the side of the tractor contains a series of holes and a pin. Place pin in the foremost hole of quadrant and secure in place with hair pin cotter. Release lift lever and place in a forward position. Attach yoke end of front lift rod to lift lever arm using top hole in R. H. side of tractor, with yoke pin and hair pin cotter. Insert lower end of lift rod into lift arm bracket of push bar and secure with hair pin cotter. The lower end of front lift rod is to point away from tractor. (See Fig. 2).



FIG. 3

At this point when lift lever is about 1/4" away from pin in decoupler, rotor housing should be in contact with the ground. This will allow plow to follow contours of the surface being plowed but quadra-plate will prevent lift lever from latching in forward position if plow is driven over a curbing.

18. Position heat deflector over muffler and adjacent to engine. Flap of deflector to be positioned against air cleaner. Secure with clamp provided. (See Fig. 2).

This deflector is provided for winter use only and must be removed in warm weather to prevent overheating and damaging of engine. The deflector directs a flow of warm air around carburetor and allows for more efficient winter operation of tractor engine.

OPERATION & LUBRICATION (Fig. 3)

19. Engagement of snow thrower is accomplished

by pushing the clutch handle forward. Pull handle toward operator for disengagement. There are grease fittings on the snow thrower. Lubricate with a general purpose automotive grease every 15 hours of operation. The occasional application of light motor oil to shaft on which the pulleys operate, will prolong their life.

Late production snow throwers now include a drive belt shield.

The clutch assembly now has a stud on each side below the clutch cross shaft.

19. Install the Shield:

1. Place on each stud a control spring and cover clip. Secure in place with 5/16" lock nut.
2. Slide shield in place.

The use of the spring and clip allows the shield to be easily removed and replaced.